



BSI Standards Publication

<http://www.china-gauges.com/>

Water meters

Part 4: Additional functionalities

National foreword

This British Standard is the UK implementation of EN 14154-4:2023 and supersedes BS EN 14154-4:2014, which is withdrawn.

The UK participation in its preparation was entrusted to Technical Committee CPI/30/7, Volume flow-rate methods.

A list of organizations represented on this committee can be obtained on request to its committee manager.

Contractual and legal considerations

This publication has been prepared in good faith, however no representation, warranty, assurance or undertaking (express or implied) is or will be made, and no responsibility or liability is or will be accepted by BSI in relation to the adequacy, accuracy, completeness or reasonableness of this publication. All and any such responsibility and liability is expressly disclaimed to the full extent permitted by the law.

This publication is provided as is, and is to be used at the recipient's own risk.

The recipient is advised to consider seeking professional guidance with respect to its use of this publication.

This publication is not intended to constitute a contract. Users are responsible for its correct application.

© The British Standards Institution 2023
Published by BSI Standards Limited 2023

ISBN 978 0 539 18212 5

ICS 91.140.60

Compliance with a British Standard cannot confer immunity from legal obligations.

This British Standard was published under the authority of the Standards Policy and Strategy Committee on 31 March 2023.

Amendments/corrigenda issued since publication

Date	Text affected
------	---------------

EUROPEAN STANDARD

EN 14154-4

NORME EUROPÉENNE

EUROPÄISCHE NORM

March 2023

ICS 91.140.60

Supersedes EN 14154-4:2014

English Version

Water meters - Part 4: Additional functionalitiesCompteurs d'eau - Partie 4 : Fonctionnalités
additionnelles

Wasserzähler - Teil 4: Zusätzliche Funktionalitäten

This European Standard was approved by CEN on 23 January 2023.

CEN members are bound to comply with the CEN/CENELEC Internal Regulations which stipulate the conditions for giving this European Standard the status of a national standard without any alteration. Up-to-date lists and bibliographical references concerning such national standards may be obtained on application to the CEN-CENELEC Management Centre or to any CEN member.

This European Standard exists in three official versions (English, French, German). A version in any other language made by translation under the responsibility of a CEN member into its own language and notified to the CEN-CENELEC Management Centre has the same status as the official versions.

CEN members are the national standards bodies of Austria, Belgium, Bulgaria, Croatia, Cyprus, Czech Republic, Denmark, Estonia, Finland, France, Germany, Greece, Hungary, Iceland, Ireland, Italy, Latvia, Lithuania, Luxembourg, Malta, Netherlands, Norway, Poland, Portugal, Republic of North Macedonia, Romania, Serbia, Slovakia, Slovenia, Spain, Sweden, Switzerland, Türkiye and United Kingdom.

EUROPEAN COMMITTEE FOR STANDARDIZATION
COMITÉ EUROPÉEN DE NORMALISATION
EUROPÄISCHES KOMITEE FÜR NORMUNG**CEN-CENELEC Management Centre: Rue de la Science 23, B-1040 Brussels**

Contents

	Page
European foreword.....	4
Introduction	5
1 Scope.....	6
2 Normative references.....	6
3 Terms and definitions	6
4 General requirements	8
4.1 Types of additional functionalities, devices and requirements	8
4.2 Connection requirements.....	8
4.3 Environmental conditions.....	8
4.4 Security.....	9
4.4.1 General.....	9
4.4.2 Software, data and hardware security	9
4.4.3 Firmware upgrade of AFD	9
4.4.4 Software identification.....	9
4.5 Power supply	9
4.6 Data storage	10
4.7 Clock requirements.....	10
4.7.1 General.....	10
4.7.2 Clock synchronisation	10
4.7.3 Clock setting.....	10
4.8 Marking.....	10
4.8.1 Requirements.....	10
4.8.2 Test.....	11
4.9 Documentation.....	11
4.9.1 General.....	11
4.9.2 Declaration of conformity.....	11
4.9.3 Instruction manual.....	11
4.10 Display.....	12
4.10.1 General.....	12
4.10.2 Requirements	12
4.10.3 Test.....	12
4.11 Metrological influence.....	12
4.11.1 Requirement.....	12
4.11.2 Test.....	12
4.12 Input to AFD / Output from AFD	13
4.12.1 General.....	13
4.12.2 Requirement.....	13
4.12.3 Test.....	13
5 Additional functionalities	13
5.1 General.....	13
5.2 Use cases.....	13
5.2.1 Scheduled read.....	13
5.2.2 Pre-programmed reading date	14
5.2.3 On demand read	14
5.2.4 History of consumption	14

5.2.5	Background leak	14
5.2.6	Burst	15
5.2.7	Reverse flow	15
5.2.8	Zero flow	16
5.2.9	Tamper of AFD	16
5.2.10	Tamper of meter	16
5.2.11	Battery low	16
5.2.12	Presence of air	17
5.2.13	Access profiles	17
6	Environmental considerations	17
Annex A (normative)	Declaration of conformity to EN 14154-4	18
Annex B (informative)	Smart Metering overview, core functionalities and descriptions	19
B.1	General	19
B.2	M2M Gateway	19
B.3	Clusters	20
B.4	Primary Use Cases	20
B.5	Secondary Use Cases	20
B.6	Primary Actors	20
B.7	Actors	20
B.8	Use Cases	20
Annex C (informative)	References to EN ISO 4064-1:2017, EN ISO 4064-2:2017, EN ISO 4064-3:2014, EN ISO 4064-4:2014, EN ISO 4064-5:2017	21
Bibliography	24

European foreword

This document (EN 14154-4:2023) has been prepared by Technical Committee CEN/TC 92 “Water meters”, the secretariat of which is held by SNV.

This European Standard shall be given the status of a national standard, either by publication of an identical text or by endorsement, at the latest by September 2023, and conflicting national standards shall be withdrawn at the latest by September 2023.

Attention is drawn to the possibility that some of the elements of this document may be the subject of patent rights. CEN shall not be held responsible for identifying any or all such patent rights.

This document supersedes EN 14154-4:2014.

This document has been prepared under a Standardization Request given to CEN by the European Commission and the European Free Trade Association.

Any feedback and questions on this document should be directed to the users' national standards body. A complete listing of these bodies can be found on the CEN website.

According to the CEN-CENELEC Internal Regulations, the national standards organisations of the following countries are bound to implement this European Standard: Austria, Belgium, Bulgaria, Croatia, Cyprus, Czech Republic, Denmark, Estonia, Finland, France, Germany, Greece, Hungary, Iceland, Ireland, Italy, Latvia, Lithuania, Luxembourg, Malta, Netherlands, Norway, Poland, Portugal, Republic of North Macedonia, Romania, Serbia, Slovakia, Slovenia, Spain, Sweden, Switzerland, Türkiye and the United Kingdom.

Introduction

This document has been developed as part of the work being undertaken by the European Standards Organizations (CEN/CENELEC/ETSI) under the Commission Mandate M/441. This document utilizes the six functionalities agreed by the Smart Meters Coordination Group (SM-CG) (see Annex B) as the basis for its additional functionalities. It is not required for the Additional Functionality Device (AFD) to incorporate all functions described in this document.

Communications for water meters are outside the scope of this document and are covered by the appropriate parts of the EN 13757 series, which provides a number of protocols and transport layers for meter communications for Gas, Water and Thermal Energy meters. The additional functionality for water meters can be provided by a number of methods, these are illustrated below, see Figure 1 (4.1), and described in detail within this document. The AFD can be integrated in the meter, attached to the meter or remote from the meter.

<http://www.china-gauges.com/>

1 Scope

This document specifies definitions, requirements and testing of additional functionalities for water meters, without metrological impact, in combination with Additional Functionality Devices (AFD) and in response to EU/EFTA Mandate M/441 EN. These AFDs are considered as “ancillary devices” as defined in EN ISO 4064-1:2017 and EN ISO 4064-4:2014.

This document does not cover the changing of metrological software within the meter or the upload/download of metrological software.

NOTE A manufacturer can claim compliance only for additional functionalities described in this document. It is not mandatory that an AFD complies with all additional functionalities described herein.

2 Normative references

The following documents are referred to in the text in such a way that some or all of their content constitutes requirements of this document. For dated references, only the edition cited applies. For undated references, the latest edition of the referenced document (including any amendments) applies.

EN ISO 4064-1:2017, *Water meters for cold potable water and hot water - Part 1: Metrological and technical requirements (ISO 4064-1:2014)*

EN ISO 4064-2:2017, *Water meters for cold potable water and hot water - Part 2: Test methods (ISO 4064-2:2014)*

EN ISO 4064-4:2014, *Water meters for cold potable water and hot water - Part 4: Non-metrological requirements not covered in ISO 4064-1 (ISO 4064-4:2014)*

EN ISO 4064-5:2017, *Water meters for cold potable water and hot water - Part 5: Installation requirements (ISO 4064-5:2014)*

EN 60529:1991, *Degrees of protection provided by enclosures (IP Code)*

3 Terms and definitions

For the purposes of this document, the terms, definitions and symbols given in EN ISO 4064-1:2017, EN ISO 4064-2:2017, EN ISO 4064-4:2014 and EN ISO 4064-5:2017 and the following apply.

NOTE The following terms and definitions are only related to additional functionalities.

3.1 functionality

process which constantly or at specified intervals, automatically or on demand, performs specific activities such as sampling data, reading a data set, verifying or changing a status, or activating a switch

3.2 additional functionality

functionality that a smart meter provides, over and above the metrological functionality covered by the Measuring Instruments Directive

3.3 additional functionality device

device providing any additional functionality

3.4

additional functionality device type 1

AFD1

additional functionality device integrated into the meter

3.5

additional functionality device type 2

AFD2

additional functionality device directly attached to the meter

3.6

additional functionality device type 3

AFD3

additional functionality device remotely connected to the meter

3.7

automatic meter reading

technology for obtaining metering data from an on-site meter by communication from a remote access point

3.8

universal time coordinated

UTC

world time, without daylight savings

3.9

reading

primary indication of the total volume passed through the meter

3.10

metrological software

software identified during the type testing examination, which is part of the meter and is critical to its metrological characteristics

3.11

register

indication of the specific section in the memory of the control and metering unit that records data as determined by the programme in the unit

3.12

event

condition requiring action or to log an action

3.13

event log

temporary or mid-term memorized listing of events, containing their occurrence, actions taken and their reset

3.14

interface

point or means of interaction between two systems

4 General requirements

4.1 Types of additional functionality devices and requirements

The additional functionality shall be provided by one of the following devices:

- AFD1; where all functions are within the same metrological enclosure as the meter;
- AFD2; where the AFD is attached directly to the meter. The manufacturer shall declare the appropriate device compatibility;
- AFD3; where the AFD is located remotely and connected to the meter via a pulse interface or communication interface. The manufacturer shall declare the appropriate device compatibility.

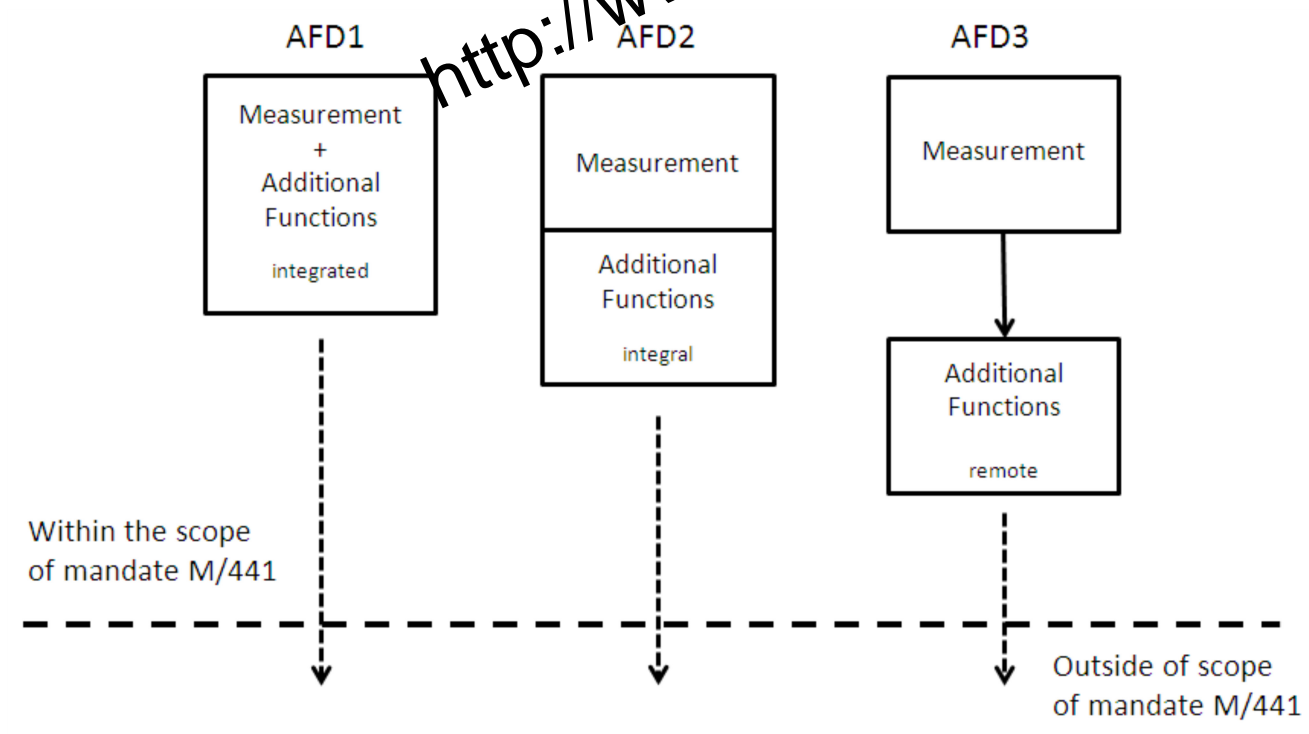

Figure 1 — Additional functionality devices

4.2 Connection requirements

The AFD2 and AFD3 shall be connected to the meter and tested as a combined unit in all the tests given in 4.11.2 to ensure the connection of the AFD to the meter has no metrological influence.

The connection of the AFD to the meter or any labelling on the meter or the AFD shall not obscure or damage any metrological seal of the meter or the regulatory marking.

When the AFD is connected, the consumer shall be able to read the primary indication on the meter to units of at least cubic meters without the use of tools.

4.3 Environmental conditions

The AFD shall work with the meter at all operating conditions of the meter as required by the appropriate standards.

Any AFD should be suitable to meet one of the environmental classes from EN ISO 4064-1:2017, A.2 and A.3 and the related tests. An AFD3 may have a different environmental class to that of the meter.

4.4 Security

4.4.1 General

The AFD shall be constructed in such a way that any unauthorized intervention shall either cause permanently visible damage to the AFD or its protective seals, or creates a report in the event log. Any physical seals shall be visibly fixed, and easily accessible.

4.4.2 Software, data and hardware security

4.4.2.1 Requirement

When tested in accordance with 4.4.2.2 the requirements below shall be met.

All available connections, ports and interfaces of the AFD which can be used for unauthorized adjustment of the AFDs characteristics and additional functionality shall be effectively secured by protective seals.

No access shall be allowed to software and firmware by unauthorised persons. Software and data shall be protected against accidental or intentional changes by the breaking of a physical seal or by using an electronic seal.

For electronic seals the following requirements shall be met:

- a) access shall only be obtained by using a password or a code;
- b) unauthorized intervention shall be registered in the event log and the type of intervention identified, and where available date and time to be included.

In the case of intended consumer access to the AFD, it shall be ensured that the access by the consumer cannot inadvertently drain the battery capacity, where applicable.

4.4.2.2 Test

Compliance with the above requirements shall be checked by visual inspection and evaluation of the manufacturer's technical documentation.

4.4.3 Firmware upgrade of AFD

This part of the document covers non-metrological upgrades only, providing there is clear separation between the metrological and non-metrological functions.

Following any upgrade, the information/functionality of the AFD shall be as declared by the manufacturer. Any data still present shall be the same as prior to the upgrade.

NOTE Further guidance is available in WELMEC Guide 7.2.

4.4.4 Software identification

The software (including version) shall have an unambiguous identifier that is retrievable.

4.5 Power supply

The power supply of the AFD shall comply with EN ISO 4064-1:2017, EN ISO 4064-4:2014 and shall be tested accordingly.

For battery powered AFD, the manufacturer shall specify the minimum operational lifetime of the battery depending on the stated functionality and operation (e.g. transmission intervals of radio communication device).

4.6 Data storage

The AFD shall be capable of storing data such as interval and event data. The manufacturer shall declare which data are stored and how to access the stored data.

The stored data shall be retained and retrievable in non-volatile memory in the event of power failure as tested according to EN ISO 4064-2:2017 unless the AFD has a non-replacable battery.

4.7 Clock requirements

4.7.1 General

Stored data shall be time stamped. The time stamps shall be generated by a clock which gives:

- a relative time stamp; or
- a non-synchronized time stamp; or
- a synchronized time stamp.

It is recommended that the synchronized time stamp within the AFD uses UTC.

The accuracy of the time stamp shall be suitable for its intended use.

4.7.2 Clock synchronisation

If the manufacturer declares that the AFD has a clock that can be synchronised with the clock of the meter, then it shall be possible to carry out this synchronization.

A record shall also be placed in the event log showing what action was taken.

4.7.3 Clock setting

If the manufacturer allows setting of the clock, access shall only be achieved by the use of an electronic seal or the breaking of a physical seal.

A record shall also be placed in the event log showing what action was taken.

4.8 Marking

4.8.1 Requirements

When tested in accordance with 4.8.2 the AFD shall as a minimum be marked as follows:

- a) the number and date of this document;
- b) identification mark or name of the manufacturer;
- c) serial number and year of manufacture;
- d) mark with respective IP rating (according to EN 60529:1991);
- e) ambient temperature range;
- f) information about the type of battery (for security, transport and recycling purposes).

NOTE Additional marking can be required by legislation (e.g. CE marking, etc.).

With the exception of b) and c), if all applicable information cannot be shown on the AFD this shall be provided on the packaging or with the documentation provided. Additionally, the necessary information could be printed in a machine readable way (QR code, bar-code, etc.) on an accessible face of the AFD.

4.8.2 Test

This test is carried out by visual inspection. Machine-readable codes shall be tested with suitable machine readers to demonstrate legibility.

4.9 Documentation

4.9.1 General

The following information shall be provided with each AFD or group of AFD's used in the same location.

4.9.2 Declaration of conformity

For each AFD a Declaration of Conformity as per Annex A shall be available in written form or electronic format and shall identify the name and address of the manufacturer and the date of issue.

4.9.3 Instruction manual

The operating instructions manual shall cover installation, operation and maintenance and shall be available in written form or electronic format and shall identify the name and address of the manufacturer and the date of issue. Each AFD or meter-AFD combination or packaging units of those shall be delivered with installation, operation and maintenance appropriate instruction manuals, including:

- safe use and hazards arising from misuse and particular features of the design when appropriate;
- rated operating conditions;
- mechanical and electromagnetic environment classes;
- safe disposal and/or recycling guidance;
- conditions for compatibility with interfaces and type of communication protocol; and
- storage requirements.

The manuals may include the following optional information:

- possible installation positions;
- safety requirements concerning commissioning and de-commissioning procedures;
- statement if a maintenance is possible and a relevant instruction;
- way of controlling the proper installation and operation;
- provisions, if any, for transport and handling;
- how to trace the right spare parts; and
- a description of each of the additional functionalities.

4.10 Display

4.10.1 General

This subclause specifies general requirements for an electronic display that may be incorporated in the AFD.

4.10.2 Requirements

Displayed data that is consumer relevant shall be easily legible and available without the use of tools.

When tested in accordance with 4.10.3, information shall be indicated either on:

- a) the display fitted to the meter;
- b) the display of an AFD;
- c) a combination of the above.

The information and flags shall be displayed by means of user action or by means of automatic and sequential scrolling for at least 10 s.

The identification and the unit of each information or parameter shall be clear and unambiguous.

The manufacturer shall declare what information can be displayed.

4.10.3 Test

A test shall be executed by visual inspection.

4.11 Metrological influence

4.11.1 Requirement

When tested in accordance with 4.11.2, the AFD shall have no influence on the metrological characteristics of the meter.

If the AFD provides a facsimile/copy of the meter's results, it shall be tested in accordance with 4.11.2 to ensure these results are identical to those on the meter.

When tested in accordance with 4.11.2 the AFD shall operate with the interfaces specified by the manufacturer and display the information as specified by the manufacturer.

4.11.2 Test

The meter shall be tested with the AFD incorporated according to the appropriate standard, i.e. EN ISO 4064-2:2017, to ensure conformity.

The manufacturer shall verify that the AFD is interoperable with those interfaces specified. In case of AFD2 or AFD3, examine the meter and AFD and ensure there is the possibility to apply a protective seal between the AFD and the meter.

With water passing through the meter under test at the flow rates of Q1 and Q3, each additional function that could have an effect on the metrological characteristics of the meter shall be operated separately. Each additional function as specified by the manufacturer shall be operated continuously for 1 h or for a minimum of 10 operations at Q1 and Q3. The meter performance shall be within the relevant MPE.

The manufacturer shall establish a reference result by repeating the identical test procedure with either:

- the same meter under test with the additional functionalities of the AFD completely disabled; or
- the same meter with a standard counter without the additional functionalities.

The value reading of the established reference shall be compared to the value reading of the meter under test and ensure that the reading has not deviated by more than one third of the MPE.

If the AFD provides a facsimile/copy of the meter under test results, the results provided by the AFD shall be verified to be identical to those on the meter under test.

4.12 Input to AFD / Output from AFD

4.12.1 General

The manufacturer shall specify the interface to the AFD (e.g. incremental volume pulses or data stream).

4.12.2 Requirement

The manufacturer shall specify the proper connections to and from the AFD.

The AFD instructions shall describe the corresponding counterparts or the electrical characteristics and parameters, the type and method of connection, installation, operating system of the AFD.

When tested in accordance with 4.12.3, a signal as described by the manufacturer shall be detected.

4.12.3 Test

The AFD shall be connected in accordance with the manufacturer's instructions and a valid signal shall be recognized that is consistent with the primary indication on the meter, and correct assembly is obvious.

5 Additional functionalities

5.1 General

The manufacturer shall describe in full all additional functionalities (use cases) that are to be provided with the AFD. The additional functionalities (use cases) described in 5.2 are not mandatory and may be offered at the discretion of the manufacturer. However, where these additional functionalities are offered, they shall comply with the tests described in 5.2.

5.2 Use cases

5.2.1 Scheduled read

5.2.1.1 Description

Scheduled read is the regular transmission of the primary indication in a pre-configured schedule.

5.2.1.2 Test procedure

Modify the calendar date in a way that it simulates the pre-configured schedule and verify that the primary indication has been transmitted by the AFD.

5.2.1.3 Acceptance criteria

The test is being considered passed if the primary indication is transmitted correctly and without exception.

5.2.2 Pre-programmed reading date

5.2.2.1 Description

The primary indication will be stored in the memory at a pre-set date.

5.2.2.2 Test procedure

Enter a requirement to store the reading by setting a date for its storage in the memory. Modify the calendar date to be shortly before the pre-set date. Check if the reading at the pre-set date has been stored in the memory.

5.2.2.3 Acceptance criteria

The test is being considered passed when the primary indication at the simulated reading date has been correctly stored in the memory and is retrievable at a later date.

5.2.3 On demand read

5.2.3.1 Description

Upon request the primary indication of the water volume consumed to date can be established and transmitted.

5.2.3.2 Test procedure

Request a report from the AFD of the primary indication of the meter and check that the transmission compares accurately with the primary indication.

5.2.3.3 Acceptance criteria

The test is considered passed if the requested primary indication has been transmitted correctly.

5.2.4 History of consumption

5.2.4.1 Requirement

The AFD may allow storage of the primary indication over a specified period of time.

5.2.4.2 Test procedure

Set the start and end date of the relevant period in such a way that they fit to two known primary indications and retrieve the primary indications from those dates from the AFD.

5.2.4.3 Acceptance criteria

The test is considered passed if the retrieved indications match the two known primary indications.

5.2.5 Background leak

5.2.5.1 Description

Either a permanent background flow or, in the case of an indirect feed system after the meter, an intermittent flow below the expected profile of consumption. This event would normally indicate that an unintentional leak is occurring after the meter. The occurrence of such an event that deviates from a pre-configured leakage flowrate range and period of time threshold shall be detected and reported.

5.2.5.2 Test procedure

The test procedure shall be executed as follows:

- a) run the meter within the pre-configured leakage flowrate range and period of time stated by the manufacturer and check that the event is reported;
- b) run the meter outside of the pre-configured leakage flowrate range and period of time stated by the manufacturer and check that the event is not reported.

This test procedure can alternatively be established via simulation.

5.2.5.3 Acceptance criteria

The test result is considered passed if, in case (a) the event is reported and in case (b) no event is reported.

5.2.6 Burst

5.2.6.1 Description

A period of flow above a specified high flow rate. This event would normally indicate that a burst has occurred. The occurrence of such an event that exceeds a pre-configured period shall be detected and reported.

5.2.6.2 Test procedure

The test procedure shall be executed as follows:

- a) Run the meter at 10 % above the specified, high flow rate for the pre-configured period and check the occurrence of the event.
- b) Run the meter at 10 % below the specified, high flow rate for the pre-configured period and check the non-occurrence of the event.

This test procedure can alternatively be established via simulation.

5.2.6.3 Acceptance criteria

The test result is considered passed if, in case (a) the event is becoming reported and in case (b) no event is reported.

5.2.7 Reverse flow

5.2.7.1 Description

A period of flow in the reverse direction (backflow). This event would normally indicate that reverse flow prevention measures have failed. The occurrence of such an event that exceeds a specified volume of water flowing in the reverse direction shall be detected.

5.2.7.2 Test procedure

Run the meter in reverse direction until the specified volume is exceeded. This test procedure can alternatively be executed via simulation.

5.2.7.3 Acceptance criteria

The test is considered passed when the event has been reported with a tolerance of ± 5 % of the specified reverse flow volume on the primary indication of the meter.

5.2.8 Zero flow

5.2.8.1 Description

A period of time with no flow detected. This event may indicate that the meter is failing to operate correctly. The occurrence of such an event that exceeds a pre-configured period of time shall be detected and reported.

5.2.8.2 Test procedure

Simulate the above pre-configured period of time accordingly.

5.2.8.3 Acceptance criteria

The test is considered passed when after the pre-configured period time of zero flow the event becomes reported within a $\pm 5\%$ accuracy of the pre-configured period.

5.2.9 Tamper of AFD

5.2.9.1 Description

This functionality only applies if the AFD is sensitive to tampering, in which case the tampering shall be detected and reported. It is the responsibility of the manufacturer to indicate possible methods of tampering.

5.2.9.2 Test procedure

The manufacturer shall provide a list of consistent test procedures to detect possible methods of tampering.

5.2.9.3 Acceptance criteria

Accordingly, the manufacturer shall provide suitable acceptance criteria for each possible method of tampering as described above.

5.2.10 Tamper of meter

5.2.10.1 Description

If the meter is capable of indicating that it has been tampered with, the AFD shall detect and report this event.

5.2.10.2 Test procedure

Simulate an event that the meter has been tampered with.

5.2.10.3 Acceptance criteria

Verify that the simulated event has been detected and reported by the AFD.

5.2.11 Battery low

5.2.11.1 Description

A battery, which is used to independently operate the AFD, is running low, indicating that the operational life of the AFD is coming to an end. The event shall be triggered in time to ensure the integrity of the measured data and allow for appropriate time for the necessary corrective action. The event shall be triggered at least 180 days before the end of the operational lifetime of the battery.

NOTE If the AFD does not have an independent power supply, the additional battery consumption is considered in the meter design according to EN ISO 4064-1:2017.

5.2.11.2 Test procedure

The manufacturer shall supply statistically representative evidence that the occurrence of the “Battery Low” event allows for appropriate time for the necessary corrective action.

5.2.11.3 Acceptance criteria

The test is being considered passed when the statistical evidence provided by the manufacturer is satisfactory for the intended purpose.

5.2.12 Presence of air

5.2.12.1 Description

The presence of air in the pipe system measured leads to incorrect primary indication on the meter resulting in erratic plausibility from billing period to billing period. If the manufacturer declares that the detection of air is available, the event should be detected and reported.

5.2.12.2 Test procedure

Run air only through the meter and establish that the AFD detects and reports the event.

5.2.12.3 Acceptance criteria

The test result is considered passed if the event is reported in the AFD.

5.2.13 Access profiles

5.2.13.1 Description

Access profiles are programmable and pre-settable specified restrictions or sets of restrictions that prevent the access to certain areas or activities within a smart metering system.

5.2.13.2 Test procedure

Apply specified access restrictions or permissions via the management system to the smart metering system. Test the integrity of the specified access restrictions and permissions as set.

5.2.13.3 Acceptance criteria

The test result is considered passed if neither a restricted area or action can be accessed nor the access to a permitted area or action is being denied.

6 Environmental considerations

Further guidance can be found in CEN Guide 4, Guide for addressing issues in environmental product standards (ed. 3: November 2008).

Annex A
 (normative)

Declaration of conformity to EN 14154-4

For each AFD a Declaration of Conformity as per this Annex shall be available in written form or electronic format and shall identify the name and address of the manufacturer and the date of issue.

Company Logo

Declaration of conformity to EN 14154-4

In the case the AFD is already subject to a declaration of conformity, the following declaration of conformity may be added to it:

We herewith declare that the following Additional Functionality Device

Type:

AFD 1	AFD 2	AFD 3
Type description:	Type description:	Type description:

is in conformance with the requirements of EN 14154-4 of the current issue

The following additional functionalities have been realized in this product and their function has been tested according to the requirements laid down in this document.

Additional functionality	Realized √	Clause in EN 14154-4
Scheduled Read		5.2.1
Pre-programmed reading date		5.2.2
On demand read		5.2.3
History of consumption		5.2.4
Background leak		5.2.5
Burst		5.2.6
Reverse flow		5.2.7
Zero flow		5.2.8
Tamper of AFD		5.2.9
Tamper of meter		5.2.10
Battery low		5.2.11
Presence of air		5.2.12
Access profiles		5.2.13

Company, town, country, date Name(s) of person(s) responsible

Annex B (informative)

Smart Metering, overview, core functionalities and descriptions

B.1 General

This Annex B is given to show the context of EN 14154-4 within the scope of the SM-CG related to the mandate M/441.

NOTE This is taken from the SM-CG technical report CEN/CLC/ETSI TR 50572:2011.

B.2 M2M Gateway

M2M Gateway is an entity associated with a meter, data concentrator and/or central system providing meter to meter service capabilities and a data path to these entities.

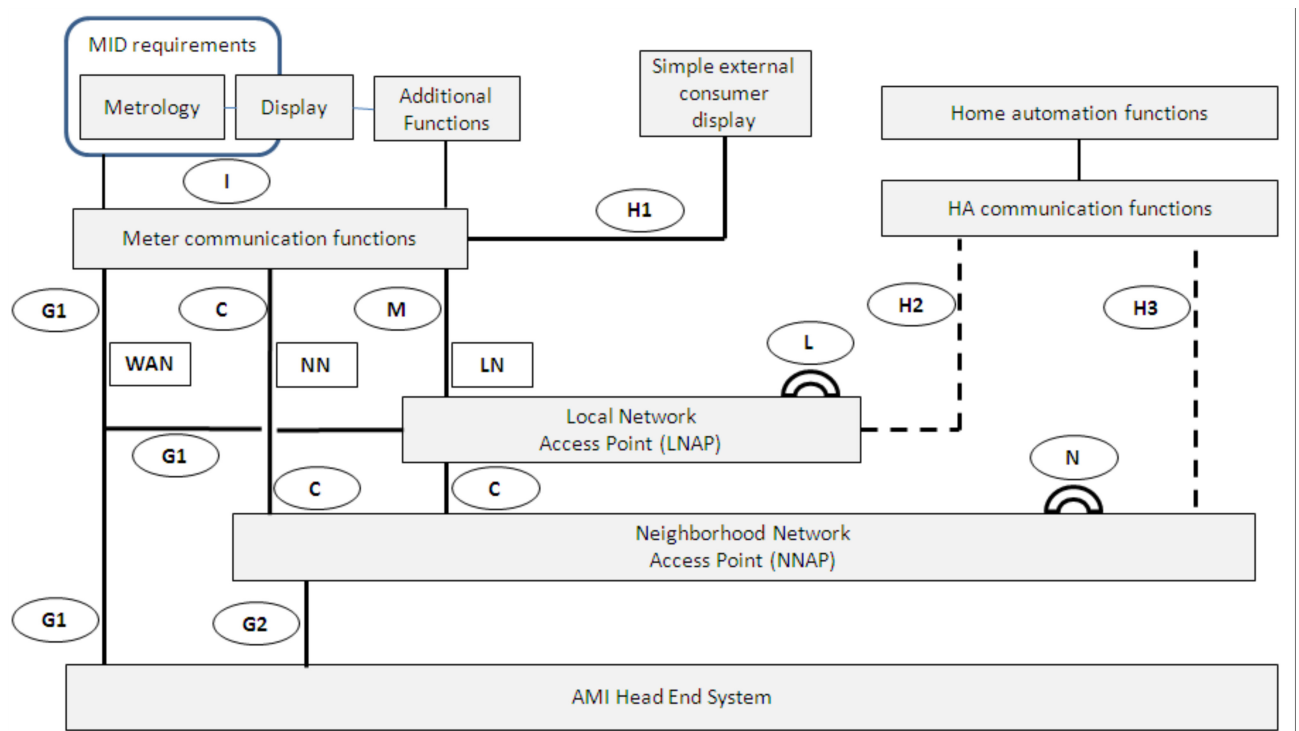

Key

Descriptions of the interfaces

H1, H2, H3 display and home automation end device interfaces

L, N LNAP / NNAP peer interfaces

G Automated Metering Infrastructure (AMI) to Head End System (HES) interface

C Neighbourhood Network Access Point interface

M metering end device interface

Figure B.1 — Reference architecture diagram for smart metering communications/definition of interfaces

B.3 Clusters

Clusters are groups of use cases that belong to the same business process.

B.4 Primary Use Cases

Primary Use Cases describe the main functions of a smart metering system. They also describe the behaviour of the system as it responds to the request of a primary actor.

B.5 Secondary Use Cases

Secondary Use Cases describe core functionalities of the system and interactions that allow Primary Use Cases to complete. They are started by and derived from Primary Use Cases only. There is no connection or interaction with any external actor.

Table B.1 — Examples of Clusters and their associated Primary and Secondary Use Cases

Main Business Process Groups (Clusters)	Examples of Primary Use Cases	Examples of Secondary Use Cases
Billing	*Obtain scheduled meter reading *Set billing parameters	**Read a meter **Write information
Customer Information Provision	*Provide information to the customer	**Write information
Configure events, status and actions	*Configure meter events and actions	**Invoke an action **Report event
Installation and configuration	*Clock synchronisation *Configure AMI device	**Invoke an action **Write information
Energy market events	*Manage consumer moving in *Manage consumer moving out	**Read a meter **Write information
Collect AMI events and status information	*Manage supply quality	**Report event **Write information

B.6 Primary Actors

Primary Actors are for example a Meter Data Collector (MDC), a Meter Operator (MO), a Metered Data Aggregator (MDA) or a Meter Data Management System (MDMS).

B.7 Actors

Actors are entities that exist outside the system and which take part in a sequence of activities in a dialogue with the system to achieve a specific goal. Actors may be end users, other systems, or hardware devices.

B.8 Use Cases

Use Cases are descriptions of the interaction between one or more Actors, represented as a sequence of simple steps.

Each Use Case is a complete series of events, described from the point of view of the Actor.

Annex C
(informative)

References to
EN ISO 4064-1:2017, EN ISO 4064-2:2017, EN ISO 4064-3:2014,
EN ISO 4064-4:2014, EN ISO 4064-5:2017

Table C.1 — References to EN ISO 4064-1:2017, EN ISO 4064-2:2017, EN ISO 4064-3:2014,
EN ISO 4064-4:2014, EN ISO 4064-5:2017

Feature or Property	EN ISO 4064 Part	EN ISO 4064 Clause
Metrological Characteristics		
Terms and Definitions	1	3
<i>Operating conditions</i>	1	3.3
Q1, minimum flow	1	3.35
Q2, transitional flow	1	3.34
Q3, permanent flow rate	1	3.32
Q4, overload flow rate	1	3.33
<i>Metrological characteristics</i>	1	3.2
MPE, Maximum Permissible Error	1	3.25
Relative error, Error	1	3.24
Metrological characteristics <i>Metrological requirements</i>	1	4
Permanent flow rate Q3	1	4.1.3
Measuring range	1	4.1.4
Relationship between Q3 and Q4	1	4.1.6
Relationship between Q2 and Q1	1	4.1.5
Reference flow rate	2	4
Maximum permissible error <i>Accuracy class 2</i>	1	4.2.3
<i>Accuracy class 1 water meters</i>	1	4.2.2
Sign of the error	1	7.2.3 7.3.6
Relative error, <i>Relative error of indication</i>	1	4.2.6

Feature or Property	EN ISO 4064 Part	EN ISO 4064 Clause
MPE lower flow range <i>Accuracy class 2</i>	1	4.2.3
MPE upper flow range <i>Accuracy class 2</i>	1	4.2.3
<i>Accuracy class 1</i>	1	4.2.2
Maximum permissible error in service	1	Annex C
Absence of flow	1	4.2.9
Meters with subassemblies	1	3.5.2
Technical Characteristics <i>Technical Requirements</i>	1	6
Indicating device	1	6.7
General requirements	1	6.7.1
Types of indicating device	1	6.7.2
Verification devices-First element-Verification scale interval	1	6.7.3
Water meters which utilize electronic devices <i>Water meters equipped with electronic devices</i>	1	5
Power supply	1	5.2
External power supply	1	5.2.2
Non-replaceable battery	1	5.2.3
Replaceable battery	1	5.2.4
Meter performance requirements <i>Performance tests for water meters with electronic devices</i>	1	Annex A
Environmental Conditions		
Climatic and mechanical environment <i>Environmental classification</i>	1	A.2
Electromagnetic environment	1	A.3
Operating Conditions		
Terms and Definitions	1	3
Rated operating conditions (ROC)	1	3.3.4
Reference Conditions (RC)	1	3.4.5
Limiting Conditions (LC)		

Feature or Property	EN ISO 4064 Part	EN ISO 4064 Clause
Operating Conditions <i>Technical Requirements</i>	1	
Rated operating conditions (ROC)		6.4
Reference Conditions (RC)	2	4
Limiting Conditions (LC)		

<http://www.china-gauges.com/>

Bibliography

- EN 13757-1, *Communication systems for meters - Part 1: Data exchange*
- EN 13757-2, *Communication systems for meters - Part 2: Wired M-Bus communication*
- EN 13757-3, *Communication systems for meters - Part 3: Application protocols*
- EN 13757-4, *Communication systems for meters - Part 4: Wireless M-Bus communication*
- EN 13757-5, *Communication systems for meters - Part 5: Wireless M-Bus relaying*
- EN 13757-6, *Communication systems for meters - Part 6: Local Bus*
- EN IEC 60086-1, *Primary batteries - Part 1: General*
- EN IEC 60086-4, *Primary batteries - Part 4: Safety of lithium batteries*
- EN 62368-1, *Audio/video, information and communication technology equipment - Part 1: Safety requirements (IEC 62368-1, modified)*
- EN 61010-1, *Safety requirements for electrical equipment for measurement, control, and laboratory use - Part 1: General requirements*
- EN 62056-21, *Electricity metering - Data exchange for meter reading, tariff and load control - Part 21: Direct local data exchange*
- EN ISO 4064-3:2014, *Water meters for cold potable water and hot water - Part 3: Test report format (ISO 4064-3:2014)*
- CEN/CLC/ETSI TR 50572:2011, *Functional Reference Architecture for Communications in Smart Metering Systems*
- CEN Guide 4, *Guide for addressing environmental issues in product standards*
- WELMEC Guide 7.2: Software Guide
- OIML R 49-1, *Water meters intended for the metering of cold potable water and hot water — Part 1: Metrological and technical requirements*

<http://www.china-gauges.com/>

British Standards Institution (BSI)

BSI is the national body responsible for preparing British Standards and other standards-related publications, information and services.

BSI is incorporated by Royal Charter. British Standards and other standardization products are published by BSI Standards Limited.

About us

We bring together business, industry, government, consumers, innovators and others to shape their combined experience and expertise into standards-based solutions.

The knowledge embodied in our standards has been carefully assembled in a dependable format and refined through our open consultation process. Organizations of all sizes and across all sectors choose standards to help them achieve their goals.

Information on standards

We can provide you with the knowledge that your organization needs to succeed. Find out more about British Standards by visiting our website at bsigroup.com/standards or contacting our Customer Services team or Knowledge Centre.

Buying standards

You can buy and download PDF versions of BSI publications, including British and adopted European and international standards, through our website at bsigroup.com/shop, where hard copies can also be purchased.

If you need international and foreign standards from other Standards Development Organizations, hard copies can be ordered from our Customer Services team.

Copyright in BSI publications

All the content in BSI publications, including British Standards, is the property of and copyrighted by BSI or some person or entity that owns copyright in the information used (such as the international standardization bodies) and has formally licensed such information to BSI for commercial publication and use.

Save for the provisions below, you may not transfer, share or disseminate any portion of the standard to any other person. You may not adapt, distribute, commercially exploit or publicly display the standard or any portion thereof in any manner whatsoever without BSI's prior written consent.

Storing and using standards

Standards purchased in soft copy format:

- A British Standard purchased in soft copy format is licensed to a sole named user for personal or internal company use only.
- The standard may be stored on more than one device provided that it is accessible by the sole named user only and that only one copy is accessed at any one time.
- A single paper copy may be printed for personal or internal company use only.

Standards purchased in hard copy format:

- A British Standard purchased in hard copy format is for personal or internal company use only.
- It may not be further reproduced – in any format – to create an additional copy. This includes scanning of the document.

If you need more than one copy of the document, or if you wish to share the document on an internal network, you can save money by choosing a subscription product (see 'Subscriptions').

Reproducing extracts

For permission to reproduce content from BSI publications contact the BSI Copyright and Licensing team.

Subscriptions

Our range of subscription services are designed to make using standards easier for you. For further information on our subscription products go to bsigroup.com/subscriptions.

With **British Standards Online (BSOL)** you'll have instant access to over 55,000 British and adopted European and international standards from your desktop. It's available 24/7 and is refreshed daily so you'll always be up to date.

You can keep in touch with standards developments and receive substantial discounts on the purchase price of standards, both in single copy and subscription format, by becoming a **BSI Subscribing Member**.

PLUS is an updating service exclusive to BSI Subscribing Members. You will automatically receive the latest hard copy of your standards when they're revised or replaced.

To find out more about becoming a BSI Subscribing Member and the benefits of membership, please visit bsigroup.com/shop.

With a **Multi-User Network Licence (MUNL)** you are able to host standards publications on your intranet. Licences can cover as few or as many users as you wish. With updates supplied as soon as they're available, you can be sure your documentation is current. For further information, email cservices@bsigroup.com.

Revisions

Our British Standards and other publications are updated by amendment or revision.

We continually improve the quality of our products and services to benefit your business. If you find an inaccuracy or ambiguity within a British Standard or other BSI publication please inform the Knowledge Centre.

Useful Contacts

Customer Services

Tel: +44 345 086 9001

Email: cservices@bsigroup.com

Subscriptions

Tel: +44 345 086 9001

Email: subscriptions@bsigroup.com

Knowledge Centre

Tel: +44 20 8996 7004

Email: knowledgecentre@bsigroup.com

Copyright & Licensing

Tel: +44 20 8996 7070

Email: copyright@bsigroup.com

BSI Group Headquarters

389 Chiswick High Road London W4 4AL UK