

BS EN 60079-0:2012+A11:2013

Incorporating corrigenda November 2012, December 2013 and October 2014



BSI Standards Publication

<http://www.china-gauges.com/>

Explosive atmospheres

Part 0: Equipment — General requirements

bsi.

...making excellence a habit.™

National foreword

This British Standard is the UK implementation of EN 60079-0:2012+A11:2013. It is derived from IEC 60079-0:2011, incorporating corrigenda November 2012, December 2013 and October 2014. It supersedes BS EN 60079-0:2012, which is withdrawn.

The CENELEC common modifications have been implemented at the appropriate places in the text. The start and finish of each common modification is indicated in the text by tags C_{11} and C_{11} . The common modifications introduced by CENELEC amendment A11 are indicated by C_{11} and C_{11} .

The UK participation in its preparation was entrusted to Technical Committee EXL 31, Equipment for explosive atmospheres.

A list of organizations represented on this committee can be obtained on request to its secretary.

This publication does not purport to include all the necessary provisions of a contract. Users are responsible for its correct application.

© The British Standards Institution 2014.
Published by BSI Standards Limited 2014

ISBN 978 0 580 88386 6

ICS 13.230; 29.260.20

Compliance with a British Standard cannot confer immunity from legal obligations.

This British Standard was published under the authority of the Standards Policy and Strategy Committee on 30 September 2012.

Amendments/corrigenda issued since publication

Date	Text affected
30 June 2013	Implementation of IEC corrigendum November 2012: Subclause 9.3.3 modified
30 April 2014	Implementation of IEC corrigendum December 2013: Subclauses 7.1.2.2 and 7.1.2.3 modified. Implementation of CENELEC amendment A11:2013. Implementation of IEC Interpretation Sheet November 2013 in National Annex NA
31 December 2014	Implementation of IEC Interpretation Sheet October 2014 in National Annex NB

**National Annex NA
(Informative)**

TC 31/Publication 60079-0 (2011), sixth edition/I-SH 01

EXPLOSIVE ATMOSPHERES –

Part 0: Equipment – General requirements

INTERPRETATION SHEET 1

This interpretation sheet has been prepared by technical committee 31: Equipment for explosive atmospheres, of IEC.

The text of this interpretation sheet is based on the following documents:

ISH	Report on voting
31/1085/ISH	31/1095/RVD

Full information on the voting for the approval of this interpretation sheet can be found in the report on voting indicated in the above table.

Interpretation of Annex A

Questions:

Is the torque used for the tensile test of A.3.1.4 required to be the same torque as the initial torque determined in A.3.1.1?

At what point in the testing sequence is the thermal endurance to heat test conducted?

Interpretation:

In A.3.1.1, a torque is applied to either the screws of a flanged compression element or the nut of a screwed compression element to compress the sealing ring to secure the mandrel. A tensile force is then applied to the mandrel to confirm the securement. The tensile force is applied for not less than 6 h. The test is carried out at an ambient temperature of $(20 \pm 5) ^\circ\text{C}$. The torque value needed for clamping to be assured by the sealing ring is acceptable if the slippage of the mandrel or cable sample as a result of the tensile force is not more than 6 mm.

Subsequently, either the complete cable gland and mandrel assembly used for the determination described above, or a new sample prepared using the same torque values, is then to be subjected to the thermal endurance tests. The maximum service temperature is considered to be $75 ^\circ\text{C}$ unless otherwise specified by the manufacturer.

NOTE 1 The $75 ^\circ\text{C}$ service temperature is the median of the branching point and entry point temperatures.

NOTE 2 Cable glands employing only metallic sealing rings and metallic parts do not require thermal endurance tests.

The subsequent test conditions and acceptance criteria are given in A.3.1.4. Prior to the application of the tensile force, the gland may be re-tightened in accordance with the manufacturer's instructions.

NOTE The torque applied to the screws or nut during retightening is not required to be the same as the initial torque applied in A.3.1.1.

In A.3.1.5, the “value needed to prevent slipping” is the torque required for A.3.1.4.

It is intended that this interpretation will be introduced in IEC 60079-0 Edition 7 and therefore an Interpretation Sheet will not be required for this or future editions.

<http://www.china-gauges.com/>

**National Annex NB
(Informative)**

TC 31/IEC 60079-0 (2011), sixth edition/I-SH 02

EXPLOSIVE ATMOSPHERES –

Part 0: Equipment – General requirements

INTERPRETATION SHEET 2

This interpretation sheet has been prepared by IEC technical committee 31: Equipment for explosive atmospheres.

The text of this interpretation sheet is based on the following documents:

ISH	Report on voting
31/1132/ISH	31/1153/RVISH

Full information on the voting for the approval of this interpretation sheet can be found in the report on voting indicated in the above table.

Following decision No 16 of the TC 31 meeting in Melbourne in 2011, the issuing of an Interpretation Sheet for IEC 60079-0:2011 (6th edition) was requested, in order to clarify the significance of the changes with respect to the 5th edition.

Question

What are the minor editorial, extensions, and major technical changes of the 6th edition with respect to the 5th edition?

Answer

The following table shows the significance of the changes.

The significance of the changes between IEC Standard, IEC 60079-0, Edition 5, 2007-10 (Including Corrigendum No.1 and Interpretation Sheet I-SH 01) and IEC 60079-0, Edition 6, 2011-06 are as listed below:

Explanation of the significance of the changes	Clause	Type		
		Minor and editorial changes	Extension	Major technical changes
Expansion of material specification data for plastics and elastomers, including UV resistance	7.1.2		x	
Addition of alternative qualification for O-rings	7.2.3			
Addition of alternative criteria for surface resistance	7.4.2 a)		x	
Addition of alternative breakdown voltage limit for non-metallic layers applied to metallic enclosures	7.4.2 c)		x	
Expansion of "X" marking options for non-metallic enclosure materials not meeting basic electrostatic requirements	7.4.2 e)		x	
Clarification that non-metallic enclosure requirements also apply to painted or coated metal enclosures	7.4.3		x	
Clarification of test to determine capacitance of accessible metal parts with reduction in acceptable capacitance	7.5 Table 9			C1
Addition of limits on zirconium content for Group III and Group II (Gb only) enclosures	8.3 8.4		x	
Introduction of "X" marking for Group III enclosures not complying with basic material requirements, similar to that existing for Group II	8.4	x		
Addition of button-head cap screws to permitted "Special Fasteners"	9.2		x	
Reference for protective earthing (PE) requirements for electrical machines to IEC 60034 1	15.3	x		
Addition of requirements for ventilating fans	17.1.5			C2
Addition of requirement for temperature rating of bearing lubricants	17.2	x		
Addition of alternative construction for disconnectors	18.2		x	
Removal of voltage limits on plugs and sockets	20.2		x	
Addition of test requirements for arc-quenching test on plugs and sockets	20.2			C3
Additional information on cell voltages	23.3 Table 12			C4
Revision to impact test of glass parts	26.4.2	x		
Revision to impact test procedure to address "bounce" of impact head	26.4.2		x	
Clarification of the test requirements for "service" and "surface" temperature	26.5.1.2 26.5.1.3	x		
Clarification of temperature rise tests for converter-fed motors	26.5.1.3		x	
Addition of alternative test method for thermal endurance	26.8 Table 15		x	
Removal of "charging test" and addition of note providing guidance	Formerly 26.14			C5
Clarification of test for the measurement of capacitance, revision of maximum capacitance	26.14			C6
Addition of tests for ventilating fans	26.15			C2
Addition of alternative o-ring testing	26.16		x	
Addition of a "Schedule of Limitations" to	28.2	x		

Explanation of the significance of the changes	Clause	Type		
		Minor and editorial changes	Extension	Major technical changes
certificates for Ex Components				
Clarification of the marking for multiple temperature classes	29.4 d) 29.5 d)	x		
Addition of marking for converter-fed motors	29.15		x	
Removal of IP marking for Group III	29.5			
Addition of specific instructions for electrical machines and for ventilating fans	30.3 30.4		x	

NOTE The technical changes referred to include the significance of technical changes in the revised IEC Standard, but they do not form an exhaustive list of all modifications from the previous version. More guidance may be found by referring to the Revised version of the standard.

Explanation of the Types of Changes:

A) Definitions

1. Minor and editorial changes:

- Clarification
- Decrease of technical requirements
- Minor technical change
- Editorial corrections

These are changes which modify requirements in an editorial or a minor technical way. They include changes of the wording to clarify technical requirements without any technical change, or a reduction in level of existing requirement.

2. Extension:

Addition of technical options

These are changes which add new or modify existing technical requirements, in a way that new options are given, but without increasing requirements for equipment that was fully compliant with the previous standard. Therefore, these will not have to be considered for products in conformity with the preceding edition.

3. Major technical changes:

- addition of technical requirements
- increase of technical requirements

These are changes to technical requirements (addition, increase of the level or removal) made in a way that a product in conformity with the preceding edition will not always be able to fulfil the requirements given in the later edition. These changes have to be considered for products in conformity with the preceding edition. For these changes additional information is provided in clause B) below.

NOTE These changes represent current technological knowledge. However, these changes should not normally have an influence on equipment already placed on the market.

B) Information about the background of 'Major technical changes'

C1 – The values in the table have been significantly reduced based on information that is intended to be published in IEC TS 60079-32-1 (currently in preparation).

C2 – The requirements for fans was added at the request of the IECEx International Product Certification Scheme.

C3 – The test has been introduced for all disconnectors as an alternative to the voltage and current restrictions in the previous standard which were considered to be arbitrary.

C4 – There has been a slight increase in some cell voltages. This is a minor change for most protection concepts but should be regarded as a major change for equipment having a type of protection relying on energy limitation, e.g. IEC 60079-11

C5 – The charging test was removed as it had been found to be not repeatable. Guidance will be given in IEC TS 60079-32-1 (currently in preparation).

C6 – The limits for capacitance have been decreased based on technical information in CLC/TR 50404.

<http://www.china-gauges.com/>

English version

Explosive atmospheres
Part 0: Equipment -
General requirements
(IEC 60079-0:2011, modified)

Atmosphères explosives -
Partie 0: Matériel -
Exigences générales
(CEI 60079-0:2011, modifiée)

Explosionsgefährdete Bereiche -
Teil 0: Betriebsmittel – Allgemeine
Anforderungen
(IEC 60079-0:2011, modifiziert)

This European Standard was approved by CENELEC on 2012-04-02. CENELEC members are bound to comply with the CEN/CENELEC Internal Regulations which stipulate the conditions for giving this European Standard the status of a national standard without any alteration.

Up-to-date lists and bibliographical references concerning such national standards may be obtained on application to the CEN-CENELEC Management Centre or to any CENELEC member.

This European Standard exists in three official versions (English, French, German). A version in any other language made by translation under the responsibility of a CENELEC member into its own language and notified to the CEN-CENELEC Management Centre has the same status as the official versions.

CENELEC members are the national electrotechnical committees of Austria, Belgium, Bulgaria, Croatia, Cyprus, the Czech Republic, Denmark, Estonia, Finland, Former Yugoslav Republic of Macedonia, France, Germany, Greece, Hungary, Iceland, Ireland, Italy, Latvia, Lithuania, Luxembourg, Malta, the Netherlands, Norway, Poland, Portugal, Romania, Slovakia, Slovenia, Spain, Sweden, Switzerland, Turkey and the United Kingdom.

CENELEC

European Committee for Electrotechnical Standardization
Comité Européen de Normalisation Electrotechnique
Europäisches Komitee für Elektrotechnische Normung

Management Centre: Avenue Marnix 17, B - 1000 Brussels

Foreword

This document (EN 60079-0:2012) consists of the text of IEC 60079-0:2011 prepared by IEC/TC 31 "Equipment for explosive atmospheres", together with the common modifications prepared by CLC/TC 31 "Electrical apparatus for potentially explosive atmospheres".

The following dates are fixed:

- latest date by which this document has to be implemented (dop) 2013-04-02
at national level by publication of an identical national standard or by endorsement
- latest date by which the national standards conflicting (dow) 2015-04-02
with this document have to be withdrawn

This document supersedes EN 60079-0:2009.

The State of the Art is included in Annex ZY "Significant changes between this European Standard and EN 60079-0:2009".

For the significant changes with respect to EN 60079-0:2009, see Annex ZY.

Annexes which are additional to those in IEC 60079-0:2011 are prefixed "Z".

Attention is drawn to the possibility that some of the elements of this document may be the subject of patent rights. CENELEC [and/or CEN] shall not be held responsible for identifying any or all such patent rights.

This document has been prepared under a mandate given to CENELEC by the European Commission and the European Free Trade Association, and supports essential requirements of EU Directive 94/9/EC.

For the relationship with EU Directive see informative Annex ZZ, which is an integral part of this document.

Endorsement notice

The text of the International Standard IEC 60079-0:2011 was approved by CENELEC as a European Standard with agreed common modifications.

In the official version, for Bibliography, the following notes have to be added for the standards indicated:

IEC/TS 60034-17	NOTE Harmonized as CLC/TS 60034-17.
IEC/TS 60034-25	NOTE Harmonized as CLC/TS 60034-25.
IEC 60034-29	NOTE Harmonized as EN 60034-29.
IEC 60079-10-1	NOTE Harmonized as EN 60079-10-1.
IEC 60079-10-2	NOTE Harmonized as EN 60079-10-2.
IEC 60079-14	NOTE Harmonized as EN 60079-14.
IEC 60079-17	NOTE Harmonized as EN 60079-17.
IEC 60079-19	NOTE Harmonized as EN 60079-19.
IEC 60079-27	NOTE Harmonized as EN 60079-27.
ISO/IEC 17000	NOTE Harmonized as EN ISO/IEC 17000.

Foreword to amendment A11

This document (EN 60079-0:2012/A11:2013) has been prepared by CLC/TC 31, "Electrical apparatus for potentially explosive atmospheres".

The following dates are fixed:

- latest date by which this document has to be implemented at national level by publication of an identical national standard or by endorsement (dop) 2014-10-07
- latest date by which the national standards conflicting with this document have to be withdrawn (dow) 2016-10-07

Attention is drawn to the possibility that some of the elements of this document may be the subject of patent rights. CENELEC [and/or CEN] shall not be held responsible for identifying any or all such patent rights.

This document has been prepared under a mandate given to CENELEC by the European Commission and the European Free Trade Association, and supports essential requirements of EU Directive 94/9/EC.

For the relationship with EU Directive see informative Annex ZZ, which is an integral part of this document.

Annex ZA
(normative)Normative references to international publications
with their corresponding European publications

The following documents, in whole or in part, are normatively referenced in this document and are indispensable for its application. For dated references, only the edition cited applies. For undated references, the latest edition of the referenced document (including any amendments) applies.

NOTE When an international publication has been modified by common modifications, indicated by (mod), the relevant EN/HD applies.

<u>Publication</u>	<u>Year</u>	<u>Title</u>	<u>EN/HD</u>	<u>Year</u>
-	-	Equipment and components intended for use in EN 1710 potentially explosive atmospheres in underground mines	-	-
-	-	Design of fans working in potentially explosive atmospheres	EN 14986	-
IEC 60034-1	-	Rotating electrical machines - Part 1: Rating and performance	EN 60034-1	-
IEC 60034-5	-	Rotating electrical machines - Part 5: Degrees of protection provided by the integral design of rotating electrical machines (IP code) - Classification	EN 60034-5	-
IEC 60050-426	-	International Electrotechnical Vocabulary - Part 426: Equipment for explosive atmospheres	-	-
IEC 60079-1	-	Explosive atmospheres - Part 1: Equipment protection by flameproof enclosures "d"	EN 60079-1	-
IEC 60079-2	-	Explosive atmospheres - Part 2: Equipment protection by pressurized enclosure "p"	EN 60079-2	-
IEC 60079-5	-	Explosive atmospheres - Part 5: Equipment protection by powder filling "q"	EN 60079-5	-
IEC 60079-6	-	Explosive atmospheres - Part 6: Equipment protection by oil immersion "o"	EN 60079-6	-
IEC 60079-7	-	Explosive atmospheres - Part 7: Equipment protection by increased safety "e"	EN 60079-7	-
IEC 60079-11	-	Explosive atmospheres - Part 11: Equipment protection by intrinsic safety "i"	EN 60079-11	-
IEC 60079-15	-	Explosive atmospheres - Part 15: Equipment protection by type of protection "n"	EN 60079-15	-
IEC 60079-18	-	Explosive atmospheres - Part 18: Equipment protection by encapsulation "m"	EN 60079-18	-
IEC 60079-20-1	-	Explosive atmospheres - Part 20-1: Material characteristics for gas and vapour classification - Test methods and data	EN 60079-20-1	-
IEC 60079-25	-	Explosive atmospheres - Part 25: Intrinsically safe electrical systems	EN 60079-25	-

<u>Publication</u>	<u>Year</u>	<u>Title</u>	<u>EN/HD</u>	<u>Year</u>
IEC 60079-26	-	Explosive atmospheres - Part 26: Equipment with equipment protection level (EPL) Ga	EN 60079-26	-
IEC 60079-28	-	Explosive atmospheres - Part 28: Protection of equipment and transmission systems using optical radiation	EN 60079-28	-
IEC 60079-30-1	-	Explosive atmospheres - Part 30-1: Electrical resistance trace heating - General and testing requirements	EN 60079-30-1	-
IEC 60079-31	-	Explosive atmospheres - Part 31: Equipment dust ignition protection by enclosure "t"	EN 60079-31	-
IEC 60086-1	-	Primary batteries - Part 1: General	EN 60086-1	-
IEC 60095-1	-	Lead-acid starter batteries - Part 1: General requirements and methods of test	-	-
IEC 60192	-	Low pressure sodium vapour lamps - Performance specifications	EN 60192	-
IEC 60216-1	-	Electrical insulating materials - Properties of thermal endurance - Part 1: Ageing procedures and evaluation of test results	EN 60216-1	-
IEC 60216-2	-	Electrical insulating materials - Thermal endurance properties - Part 2: Determination of thermal endurance properties of electrical insulating materials - Choice of test criteria	EN 60216-2	-
IEC 60243-1	-	Electrical strength of insulating materials - Test methods - Part 1: Tests at power frequencies	EN 60243-1	-
IEC 60254	Series	Lead-acid traction batteries	EN 60254	Series
IEC 60423	-	Conduit systems for cable management - Outside diameters of conduits for electrical installations and threads for conduits and fittings	EN 60423	-
IEC 60529	-	Degrees of protection provided by enclosures (IP Code)	EN 60529	-
IEC 60622	-	Secondary cells and batteries containing alkaline or other non-acid electrolytes - Sealed nickel-cadmium prismatic rechargeable single cells	EN 60622	-
IEC 60623	-	Secondary cells and batteries containing alkaline or other non-acid electrolytes - Vented nickel-cadmium prismatic rechargeable single cells	EN 60623	-
IEC 60662	-	High pressure sodium vapour lamps - Performance specifications	EN 60662	-
IEC 60664-1	-	Insulation coordination for equipment within low-voltage systems - Part 1: Principles, requirements and tests	EN 60664-1	-
IEC 60947-1	-	Low-voltage switchgear and controlgear - Part 1: General rules	EN 60947-1	-

<http://www.china-gauges.com/>

<u>Publication</u>	<u>Year</u>	<u>Title</u>	<u>EN/HD</u>	<u>Year</u>
IEC 60896-11	-	Stationary lead-acid batteries - Part 11: Vented types - General requirements and methods of tests	EN 60896-11	-
IEC 60896-21	-	Stationary lead-acid batteries - Part 21: Valve regulated types - Methods of test	EN 60896-21	-
IEC 60952	Series	Aircraft batteries	EN 60952	Series
IEC 61056-1	-	General purpose lead-acid batteries (valve- regulated types) - Part 1: General requirements, functional characteristics - Methods of test	EN 61056-1	-
IEC 61241-4	-	Electrical apparatus for use in the presence of combustible dust - Part 4: Type of protection and	EN 61241-4	-
IEC 61427	-	Secondary cells and batteries for photovoltaic energy systems (PVES) - General requirements and methods of test	EN 61427	-
IEC 61951-1	-	Secondary cells and batteries containing alkaline or other non-acid electrolytes - Portable sealed rechargeable single cells - Part 1: Nickel-cadmium	EN 61951-1	-
IEC 61951-2	-	Secondary cells and batteries containing alkaline or other non-acid electrolytes - Portable sealed rechargeable single cells - Part 2: Nickel-metal hydride	EN 61951-2	-
IEC 61960	-	Secondary cells and batteries containing alkaline or other non-acid electrolytes - Secondary lithium cells and batteries for portable applications	EN 61960	-
IEC 62013-1	-	Caplights for use in mines susceptible to firedamp - Part 1: General requirements - Construction and testing in relation to the risk of explosion	EN 62013-1	-
ISO 178	-	Plastics - Determination of flexural properties	EN ISO 178	-
ISO 179	Series	Plastics - Determination of Charpy impact properties	EN ISO 179	Series
ISO 262	-	ISO general-purpose metric screw threads - Selected sizes for screws, bolts and nuts	-	-
ISO 273	-	Fasteners - Clearance holes for bolts and screws	EN 20273	-
ISO 286-2	-	ISO system of limits and fits - Part 2: Tables of standard tolerance grades and limit deviations for holes and shafts	EN ISO 286-2	-
ISO 527-2	-	Plastics - Determination of tensile properties - Part 2: Test conditions for moulding and extrusion plastics	EN ISO 527-2	-
ISO 965-1	-	ISO general-purpose metric screw threads - Tolerances - Part 1: Principles and basic data	-	-
ISO 965-3	-	ISO general-purpose metric screw threads - Tolerances - Part 3: Deviations for constructional threads	-	-
ISO 1817	-	Rubber, vulcanized - Determination of the effect- of liquids	-	-

<http://www.china-gauges.com/>

<u>Publication</u>	<u>Year</u>	<u>Title</u>	<u>EN/HD</u>	<u>Year</u>
ISO 3601-1	-	Fluid systems - Sealing devices - O-rings - Part 1: Inside diameters, cross-sections, tolerances and size identification code	-	-
ISO 3601-2	-	Fluid power systems - O-rings - Part 2: Housing dimensions for general applications	-	-
ISO 4014	-	Hexagon head bolts - Product grades A and B	EN ISO 4014	-
ISO 4017	-	Hexagon head screws - Product grades A and B	EN ISO 4017	-
ISO 4026	-	Hexagon socket set screws with flat point	EN ISO 4026	-
ISO 4027	-	Hexagon socket set screws with cone point	EN ISO 4027	-
ISO 4028	-	Hexagon socket set screws with dog point	EN ISO 4028	-
ISO 4029	-	Hexagon socket set screws with cup point	EN ISO 4029	-
ISO 4032	-	Hexagon nuts, style 1 - Product grades A and B	EN ISO 4032	-
ISO 4762	-	Hexagon socket head cap screws	EN ISO 4762	-
ISO 4892-2	-	Plastics - Methods of exposure to laboratory light sources - Part 2: Xenon-arc lamps	EN ISO 4892-2	-
ISO 7380-1	-	Button head screws - Part 1: Hexagon socket button head screws	EN ISO 7380-1	-
ISO 14583	-	Hexalobular socket pan head screws	EN ISO 14583	-
ANSI/UL 746B	-	Polymeric Materials - Long-Term Property Evaluations	-	-
ANSI/UL 746C	-	Polymeric Materials - Used in Electrical Equipment Evaluations	-	-

<http://www.china-gauges.com/>

Annex ZY
(informative)

Additional Information relating to the European ATEX Directive 94/9/EC

ZY.1 Equipment Groups

In all cases Equipment Protection Levels (EPL) as defined by EN 60079-0 are related to the corresponding Equipment Groups and Equipment Categories according to the following table. The same applies if a standard makes reference to the intended use of equipment in Zones according to the definitions in EN 60079-10-1 and EN 60079-10-2.

Table ZY.1

EN 60079-0		Directive 94/9/EC		EN 60079-10-X
EPL	Group	Equipment Group	Equipment Category	Zones
Ma	I	I	M 1	Not Applicable
Mb			M 2	
Ga	II	II	1G	0
Gb			2G	1
Gc			3G	2
Da	III	II	1D	20
Db			2D	21
Dc			3D	22



ZY.2 Instructions

The manufacturer or his authorized representative in the Community is to draw up the instructions for use in the required Community languages.

ZY.3 Marking

The marking according to this standard is to be supplemented by the marking according to Directive 94/9/EC. Examples are given below.

European marking examples

Directive part	Standard part	Equipment example
 I M2	Ex d I Mb	Mining equipment, type of protection "Flameproof Enclosure" d
 II 2G	Ex e IIB T4 Gb	Gas explosion protected equipment type of protection, "Increased Safety" e
 II 1D	Ex ma IIIC 120°C Da	Dust explosion protected equipment, type of protection "Encapsulation" ma

NOTE  Attention is drawn to the requirement in 29.8:

The Ex marking for explosive gas atmospheres and explosive dust atmospheres should be separate and not combined:

 II 1 G Ex ia IIB T4

 II 1 D Ex ia IIIC T120 °C

Alternatively, the ATEX marking may be combined and the standard marking kept separate, as follows:

 II 1 GD

Ex ia IIB T4

Ex ia IIIC T120 °C 

ZY.4 Significant changes between this European Standard and EN 60079-0:2009

This European Standard supersedes EN 60079-0:2009.

Table ZY.2 – Significant changes with respect to EN 60079-0:2009

Significant Changes	Clause	Type		
		Minor and editorial changes	Extension	Major technical changes
Expansion of material specification data for plastics and elastomers, including UV resistance	7.1.2		x	
Addition of alternative qualification for O-rings	7.2.3		x	
Addition of alternative criteria for surface resistance	7.4.2 a)		x	
Addition of alternative breakdown voltage limit for non-metallic layers applied to metallic enclosures	7.4.2 c)		x	
Expansion of “X” marking options for non-metallic enclosure materials not meeting basic electrostatic requirements	7.4.2 d) 7.4.2 e)		x	
Clarification that non-metallic enclosure requirements also apply to painted or coated metal enclosures	7.4.3		x	
Clarification of test to determine capacitance of accessible metal parts with reduction in acceptable capacitance	7.5 Table 9			C1
Addition of limits on zirconium content for Group III and Group II (Gb only) enclosures	8.3 8.4		x	
Introduction of “X” marking for Group III enclosures not complying with basic material requirements, similar to that existing for Group II	8.4	x		
Addition of button-head cap screws to permitted “Special Fasteners”	9.2		x	
Reference for protective earthing (PE) requirements for rotating electrical machines to EN 60034 1	15.3	x		
Addition of requirements for ventilating fans	17.1.5			C2

Significant Changes	Clause	Type		
		Minor and editorial changes	Extension	Major technical changes
Addition of alternative construction for disconnectors	18.2		x	
Removal of voltage limits on plugs and sockets	20.2			
Addition of test requirements for arc-quenching test on plugs and sockets	20.2			C3
Additional information on cell voltages	23.3 Annex 12			C4
Revision to impact test of glass parts	26.4.2	x		
Revision to impact test procedure to address "bounce" of impact head	26.4.2		x	
Clarification of the test requirements for "service" and "surface" temperature	26.5.1.2 26.5.1.3	x		
Addition of temperature rise tests for converter-fed motors	26.5.1.3		x	
Addition of alternative test method for thermal endurance	26.8 Table 15		x	
Removal of "charging test" and addition of note providing guidance	Formerly 26.14			C5
Clarification of test for the measurement of capacitance	26.14	x		
Addition of a "Schedule of Limitations" to certificates for Ex Components	28.2	x		
Clarification of the marking for multiple temperature classes	29.3 d)	x		
Addition of marking for converter-fed motors	29.14	x		
Removal of IP marking for Group III	29.4 29.15	x		
Addition of specific instructions for electrical machines and for ventilating fans	30.3 30.4	x		

NOTE 1 The technical changes referred include the significant technical changes from the EN revised but is not an exhaustive list of all modifications from the previous version.

Explanations:

A) Definitions

Minor and editorial changes

clarification
decrease of technical requirements
minor technical change
editorial corrections

Changes in a standard classified as ‘Minor and editorial changes’ refer to changes regarding the previous standard, which modify requirements in an editorial or a minor technical way. Also changes of the wording to clarify technical requirements without any technical change are classified as ‘Minor and editorial changes’.

A reduction in level of existing requirement is also classified as ‘Minor and editorial changes’

Extension

addition of technical options

Changes in a standard classified as ‘extension’ refers to changes regarding the previous standard, which add new or modify existing technical requirements in a way that new options are given, but without increasing requirements for equipment that was fully compliant with the previous standard. Therefore these ‘extensions’ will not have to be considered for products in conformity with the preceding edition.

Major technical change

addition of technical requirements

increase of technical requirements

Changes in a standard classified as ‘Major technical change’ refer to changes regarding the previous standard, which add new or increase the level of existing technical requirements, in a way that a product in conformity with the preceding standard will not always be able to fulfil the requirements given in the standard. ‘Major technical changes’ have to be considered for products in conformity with the preceding edition. For every change classified as ‘Major Technical Change’ additional information is provided in B) of Annex ZY.

NOTE 2 These changes represent current technological knowledge¹. However, these changes should not normally have an influence on equipment already placed on the market.

B) Information about the background of ‘Major Technical Changes’

C1 – The values in the table have been significantly reduced based on information that is intended to be published in IEC 60079-32 (currently in preparation).

C2 – The requirements for fans which are not integral to the cooling system of a rotating electrical machine were added to the IEC version of the standard at the request of the IECEx International Product Certification Scheme as such requirements do not exist elsewhere in international standards. These requirements were removed from the EN version of the standard by common modification and replaced by reference to other European standards harmonised under the ATEX Directive 94/9/EC. If this clause is being used for IECEx purposes, it should be noted that the major new requirement for fans relates to the back pressure considerations which are also specifically addressed in EN 14986:2007.

C3 – The test has been introduced for all disconnectors as an alternative to the voltage and current restrictions in the previous standard which were considered to be arbitrary.

C4 – There has been a slight increase in some cell voltages. This is a minor change for most protection concepts but should be regarded as a major change for equipment having a type of protection relying on energy limitation, e.g. EN 60079-11

C5 – The charging test was removed as it had been found to be not repeatable. Guidance is currently provided in CLC/TR 50404 and will be given in IEC 60079-32 which is in preparation.

¹ see also ATEX Guide 10.3 and Annex ZZ.

Annex ZZ
(informative)

Coverage of Essential Requirements of EU Directives

This European Standard has been prepared under a mandate given to CENELEC by the European Commission and the European Free Trade Association and within its scope the standard covers only the following essential requirements out of those given in Annex II of the EU Directive 94/9/EC.

- ER 1.0.1 (partly), ER 1.0.2 to ER 1.0.4, ER 1.0.5 (partly) and ER 1.0.6 (partly)
- ER 1.1
- ER 1.2.1, ER 1.2.2, ER 1.2.4 to ER 1.2.6, ER 1.2.7 (partly) and ER 1.2.8 (partly)
- ER 1.3.1 to ER 1.3.4
- ER 1.4.1 (partly) and ER 1.4.2 (partly)
- ER 1.6.2 and ER 1.6.4
- ER 2.0 to ER 2.3

Compliance with this standard provides one means of conformity with the specified essential requirements of the Directive concerned.

WARNING: Other requirements and other EU Directives may be applicable to the products falling within the scope of this standard. **Annex ZZ**

CONTENTS

FOREWORD.....	17
1 Scope.....	20
2 Normative references	21
3 Terms and definitions	24
4 Equipment grouping	36
4.1 Group I.....	36
4.2 Group II.....	36
4.3 Group III.....	36
4.4 Equipment for a particular explosive atmosphere.....	37
5 Temperatures.....	37
5.1 Environmental influences	37
5.1.1 Ambient temperature	37
5.1.2 External source of heating or cooling.....	37
5.2 Service temperature	37
5.3 Maximum surface temperature	38
5.3.1 Determination of maximum surface temperature	38
5.3.2 Limitation of maximum surface temperature.....	38
5.3.3 Small component temperature for Group I or Group II electrical equipment	39
6 Requirements for all electrical equipment	40
6.1 General.....	40
6.2 Mechanical strength of equipment	40
6.3 Opening times	40
6.4 Circulating currents in enclosures (e.g. of large electrical machines).....	41
6.5 Gasket retention.....	41
6.6 Electromagnetic and ultrasonic energy radiating equipment	41
6.6.1 Radio frequency sources	41
6.6.2 Lasers or other continuous wave sources	42
6.6.3 Ultrasonic sources	43
7 Non-metallic enclosures and non-metallic parts of enclosures	43
7.1 General.....	43
7.1.1 Applicability.....	43
7.1.2 Specification of materials.....	43
7.2 Thermal endurance	44
7.2.1 Tests for thermal endurance	44
7.2.2 Material selection	34
7.2.3 Alternative qualification of elastomeric sealing O-rings.....	34
7.3 Resistance to light.....	44
7.4 Electrostatic charges on external non-metallic materials.....	45
7.4.1 Applicability.....	45
7.4.2 Avoidance of a build-up of electrostatic charge on Group I or Group II electrical equipment	45
7.4.3 Avoidance of a build-up of electrostatic charge on equipment for Group III.....	47
7.5 Accessible metal parts	47
8 Metallic enclosures and metallic parts of enclosures.....	48

8.1	Material composition	48
8.2	Group I.....	48
8.3	Group II.....	48
8.4	Group III.....	48
9	Fasteners	49
9.1	General	49
9.2	Special fasteners.....	49
9.3	Holes for special fasteners	50
9.3.1	Thread engagement	50
9.3.2	Tolerance and clearance	50
9.3.3	Hexagon socket set screws.....	51
10	Interlocking devices.....	51
11	Bushings	51
12	Materials used for cementing.....	51
13	Ex Components	52
13.1	General	52
13.2	Mounting	52
13.3	Internal mounting	52
13.4	External mounting	52
13.5	Ex Component certificate	52
14	Connection facilities and termination compartments	53
14.1	General	53
14.2	Termination compartment.....	53
14.3	Type of protection	53
14.4	Creepage and clearance	53
15	Connection facilities for earthing or bonding conductors	53
15.1	Equipment requiring earthing.....	53
15.1.1	Internal.....	53
15.1.2	External.....	53
15.2	Equipment not requiring earthing.....	53
15.3	Size of conductor connection.....	54
15.4	Protection against corrosion	54
15.5	Secureness of electrical connections	54
16	Entries into enclosures	54
16.1	General	54
16.2	Identification of entries	54
16.3	Cable glands	55
16.4	Blanking elements	55
16.5	Thread adapters	55
16.6	Temperature at branching point and entry point.....	55
16.7	Electrostatic charges of cable sheaths	56
17	Supplementary requirements for rotating machines	56
17.1	Ventilation	56
17.1.1	Ventilation openings	56
17.1.2	Materials for external fans	57
17.1.3	Cooling fans of rotating machines.....	57
17.1.4	Auxiliary motor cooling fans.....	57
17.1.5	Ventilating fans.....	57

17.2	Bearings.....	58
18	Supplementary requirements for switchgear	58
18.1	Flammable dielectric	58
18.2	Disconnectors	58
18.3	Group I – Provisions for locking.....	58
18.4	Doors and covers	58
19	Supplementary requirements for fuses	59
20	Supplementary requirements for plugs, socket outlets and connectors	59
20.1	General.....	59
20.2	Explosive gas atmospheres.....	59
20.3	Explosive dust atmospheres.....	59
20.4	Energized plugs	60
21	Supplementary requirements for luminaires	60
21.1	General.....	60
21.2	Covers for luminaires of EPL Mb, EPL Gb, or EPL Db	60
21.3	Covers for luminaires of EPL Gc or EPL Dc.....	60
21.4	Sodium lamps	61
22	Supplementary requirements for caplights and handlights	61
22.1	Group I caplights.....	61
22.2	Group II and Group III caplights and handlights	61
23	Equipment incorporating cells and batteries	61
23.1	General	61
23.2	Batteries.....	61
23.3	Cell types	61
23.4	Cells in a battery	63
23.5	Ratings of batteries	63
23.6	Interchangeability	63
23.7	Charging of primary batteries.....	63
23.8	Leakage	63
23.9	Connections	63
23.10	Orientation.....	63
23.11	Replacement of cells or batteries.....	63
23.12	Replaceable battery pack	64
24	Documentation	64
25	Compliance of prototype or sample with documents	64
26	Type tests	64
26.1	General.....	64
26.2	Test configuration.....	64
26.3	Tests in explosive test mixtures.....	64
26.4	Tests of enclosures	65
26.4.1	Order of tests	65
26.4.2	Resistance to impact	66
26.4.3	Drop test	68
26.4.4	Acceptance criteria.....	68
26.4.5	Degree of protection (IP) by enclosures.....	68
26.5	Thermal tests	69
26.5.1	Temperature measurement.....	69
26.5.2	Thermal shock test	70

<http://www.china-gauges.com/>

26.5.3	Small component ignition test (Group I and Group II).....	71
26.6	Torque test for bushings.....	71
26.6.1	Test procedure.....	71
26.6.2	Acceptance criteria.....	72
26.7	Non-metallic enclosures or non-metallic parts of enclosures.....	72
26.7.1	General.....	72
26.7.2	Test temperatures.....	72
26.8	Thermal endurance to heat.....	72
26.9	Thermal endurance to cold.....	73
26.10	Resistance to light.....	73
26.10.1	Test procedure.....	73
26.10.2	Acceptance criteria.....	74
26.11	Resistance to chemical agents for Group I electrical equipment.....	74
26.12	Earth continuity.....	74
26.13	Surface resistance test of parts of enclosures of non-metallic materials.....	76
26.14	Measurement of capacitance.....	77
26.14.1	General.....	77
26.14.2	Test procedure.....	77
26.15	Verification of ratings of ventilating fans.....	78
26.16	Alternative qualification of elastomeric sealing O-rings.....	78
27	Routine tests.....	78
28	Manufacturer's responsibility.....	79
28.1	Conformity with the documentation.....	79
28.2	Certificate.....	79
28.3	Responsibility for marking.....	79
29	Marking.....	79
29.1	Applicability.....	79
29.2	Location.....	79
29.3	General.....	79
29.4	Ex marking for explosive gas atmospheres.....	80
29.5	Ex marking for explosive dust atmospheres.....	82
29.6	Combined types (or levels) of protection.....	83
29.7	Multiple types of protection.....	83
29.8	Ga equipment using two independent Gb types (or levels) of protection.....	84
29.9	Ex Components.....	84
29.10	Small equipment and small Ex Components.....	84
29.11	Extremely small equipment and extremely small Ex Components.....	85
29.12	Warning markings.....	85
29.13	Alternate marking of equipment protection levels (EPLs).....	85
29.13.1	Alternate marking of type of protection for explosive gas atmospheres.....	86
29.13.2	Alternate marking of type of protection for explosive dust atmospheres.....	86
29.14	Cells and batteries.....	86
29.15	Converter-fed electrical machines.....	87
29.16	Examples of marking.....	87
30	Instructions.....	90
30.1	General.....	90
30.2	Cells and batteries.....	90

30.3 Electrical machines	91
30.4 Ventilating fans	91
Annex A (normative) Supplementary requirements for cable glands	92
Annex B (normative) Requirements for Ex Components	99
Annex C (informative) Example of rig for resistance to impact test	101
Annex D (informative) Motors supplied by converters	102
Annex E (informative) Temperature rise testing of electric machines	103
Annex F (informative) Guideline flowchart for tests of non-metallic enclosures or non-metallic parts of enclosures (26.4)	105
Bibliography	106
Figure 1 – Tolerances and clearance for threaded fasteners	50
Figure 2 – Contact surface under head of fastener with a reduced shank	51
Figure 3 – Illustration of entry points and branching points	56
Figure 4 – Assembly of test sample for earth-continuity test	76
Figure 5 – Test piece with painted electrodes	77
Figure 6 – Compression set of an O-ring	78
Figure A.1 – Illustration of the terms used for cable glands	93
Figure A.2 – Rounded edge of the point of entry of the flexible cable	94
Figure C.1 – Example of rig for resistance to impact test	101
Figure F.1 – Non-metallic enclosures or non-metallic parts of enclosures	105
Table 1 – Ambient temperatures in service and additional marking	37
Table 2 – Classification of maximum surface temperatures for Group II electrical equipment	38
Table 3a – Assessment of temperature classification according to component size at 40 °C ambient temperature	39
Table 3b – Assessment of temperature classification Component surface area ≥ 20 mm ² Variation in maximum power dissipation with ambient temperature	39
Table 4 – Radio frequency power thresholds	42
Table 5 – Radio-frequency energy thresholds	42
Table 6 – Limitation of surface areas	46
Table 7 – Maximum diameter or width	46
Table 8 – Limitation of thickness of non-metallic layer	47
Table 9 – Maximum capacitance of unearthed metal parts	48
Table 10 – Minimum cross-sectional area of PE conductors	54
Table 11 – Primary cells	62
Table 12 – Secondary cells	62
Table 13 – Tests for resistance to impact	67
Table 14 – Torque to be applied to the stem of bushing used for connection facilities	72
Table 15 – Thermal endurance test	73
Table 16 – Text of warning markings	85
Table B.1 – Clauses with which Ex Components shall comply	99

INTERNATIONAL ELECTROTECHNICAL COMMISSION

EXPLOSIVE ATMOSPHERES –

Part 0: Equipment – General requirements

FOREWORD

- 1) The International Electrotechnical Commission (IEC) is a worldwide organization for standardization comprising all national electrotechnical committees (IEC National Committees). The object of IEC is to promote international co-operation on all questions concerning standardization in the electrical and electronic fields. To this end and in addition to other activities, IEC publishes International Standards, Technical Specifications, Technical Reports, Publicly Available Specifications (PAS) and Guides (hereafter referred to as "IEC Publication(s)"). Their preparation is entrusted to technical committees; any IEC National Committee interested in the subject dealt with may participate in this preparatory work. International, governmental and non-governmental organizations liaising with the IEC also participate in this preparation. IEC collaborates closely with the International Organization for Standardization (ISO) in accordance with conditions determined by agreement between the two organizations.
- 2) The formal decisions or agreements of IEC on technical matters express, as nearly as possible, an international consensus of opinion on the relevant subjects since each technical committee has representation from all interested IEC National Committees.
- 3) IEC Publications have the form of recommendations for international use and are accepted by IEC National Committees in that sense. While all reasonable efforts are made to ensure that the technical content of IEC Publications is accurate, IEC cannot be held responsible for the way in which they are used or for any misinterpretation by any end user.
- 4) In order to promote international uniformity, IEC National Committees undertake to apply IEC Publications transparently to the maximum extent possible in their national and regional publications. Any divergence between any IEC Publication and the corresponding national or regional publication shall be clearly indicated in the latter.
- 5) IEC itself does not provide any attestation of conformity. Independent certification bodies provide conformity assessment services and, in some areas, access to IEC marks of conformity. IEC is not responsible for any services carried out by independent certification bodies.
- 6) All users should ensure that they have the latest edition of this publication.
- 7) No liability shall attach to IEC or its directors, employees, servants or agents including individual experts and members of its technical committees and IEC National Committees for any personal injury, property damage or other damage of any nature whatsoever, whether direct or indirect, or for costs (including legal fees) and expenses arising out of the publication, use of, or reliance upon, this IEC Publication or any other IEC Publications.
- 8) Attention is drawn to the Normative references cited in this publication. Use of the referenced publications is indispensable for the correct application of this publication.
- 9) Attention is drawn to the possibility that some of the elements of this IEC Publication may be the subject of patent rights. IEC shall not be held responsible for identifying any or all such patent rights.

International Standard IEC 60079-0 has been prepared by IEC technical committee 31: Equipment for explosive atmospheres.

This sixth edition cancels and replaces the fifth edition, published in 2007, and constitutes a full technical revision.

The significant changes with respect to the previous edition are listed below:

- Relocation of definitions for energy limitation parameters to IEC 60079-11
- Addition of note to clarify that the non-metallic "enclosure" requirements are applied to other than "enclosures" by some of the subparts
- Expansion of material specification data for plastics and elastomers, including UV resistance
- Addition of alternative qualification for O-rings
- Addition of alternative criteria for surface resistance

- Addition of breakdown voltage limit for non-metallic layers applied to metallic enclosures
- Expansion of “X” marking options for non-metallic enclosure materials not meeting basic electrostatic requirements
- Clarification that non-metallic enclosure requirements also apply to painted or powder coated metal enclosures
- Clarification of test to determine capacitance of accessible metal parts with reduction in acceptable capacitance
- Addition of limits on zirconium content for Group III and Group II (Bb only) enclosures
- Introduction of “X” marking for Group III enclosures not complying with basic material requirements, similar to that existing for Group II
- Addition of button-head cap screws to permitted “Special Fasteners”
- Reference for protective earthing (PE) requirements for electrical machines to IEC 60034-1
- Clarification of terminology for cable glands, blanking elements, and thread adapters
- Addition of requirements for ventilating fans
- Addition of alternative construction for disconnectors
- Removal of voltage limits on plugs and sockets
- Addition of test requirements for arc-quenching test on plugs and sockets
- Update of cell and battery information to reflect latest standards
- Revision to impact test of glass parts
- Revision to impact test procedure to address “bounce” of impact head
- Clarification of the test requirements for “service” and “surface” temperature
- Addition of temperature rise tests for converter-fed motors
- Addition of alternative test method for thermal endurance
- Removal of “charging test” and addition of note providing guidance
- Clarification of test for the measurement of capacitance
- Addition of a “Schedule of Limitations” to certificates for Ex Components
- Clarification of the marking for multiple temperature classes
- Addition of marking for converter-fed motors
- Removal of IP marking for Group III
- Addition of specific instructions for electrical machines
- Addition of specific instructions for ventilating fans
- Update to informative Annex D on converter-fed motors
- Update to informative Annex E on temperature testing of motors
- Addition of informative Annex F, flowchart for testing of non-metallic enclosures and non-metallic parts of enclosures

The text of this standard is based on the following documents:

FDIS	Report on voting
31/922/FDIS	31/939/RVD

Full information on the voting for the approval of this standard can be found in the report on voting indicated in the above table.

This publication has been drafted in accordance with the ISO/IEC Directives, Part 2.

A list of all parts of the IEC 60079 series, under the general title *Explosive atmospheres*, can be found on the IEC website.

Future standards in this series will carry the new general title as cited above. Titles of existing standards in this series will be updated at the time of a new edition.

The committee has decided that the contents of this publication will remain unchanged until the stability date indicated on the IEC web site under "<http://webstore.iec.ch>" in the data related to the specific publication. At this date, the publication will be

- reconfirmed,
- withdrawn,
- replaced by a revised edition, or
- amended.

<http://www.china-gauges.com/>

EXPLOSIVE ATMOSPHERES –

Part 0: Equipment – General requirements

1 Scope

This part of IEC 60079 specifies the general requirements for construction, testing and marking of electrical equipment and Ex Components intended for use in explosive atmospheres.

The standard atmospheric conditions (relating to the explosion characteristics of the atmosphere) under which it may be assumed that electrical equipment can be operated are:

- temperature -20 °C to $+60\text{ °C}$;
- pressure 80 kPa (0,8 bar) to 110 kPa (1,1 bar); and
- air with normal oxygen content, typically 21 % v/v.

This standard and other standards supplementing this standard specify additional test requirements for equipment operating outside the standard temperature range, but further additional consideration and additional testing may be required for equipment operating outside the standard atmospheric pressure range and standard oxygen content, particularly with respect to types of protection that depend on quenching of a flame such as 'flameproof enclosure "d"' (IEC 60079-1) or limitation of energy, 'intrinsic safety "i"' (IEC 60079-11).

NOTE 1 Although the standard atmospheric conditions above give a temperature range for the atmosphere of -20 °C to $+60\text{ °C}$, the normal ambient temperature range for the equipment is -20 °C to $+40\text{ °C}$, unless otherwise specified and marked. See 5.1.1. It is considered that -20 °C to $+40\text{ °C}$ is appropriate for most equipment and that to manufacture all equipment to be suitable for a standard atmosphere upper ambient temperature of $+60\text{ °C}$ would place unnecessary design constraints.

NOTE 2 Requirements given in this standard result from an ignition hazard assessment made on electrical equipment. The ignition sources taken into account are those found associated with this type of equipment, such as hot surfaces, mechanically generated sparks, mechanical impacts resulting in thermite reactions, electrical arcing and static electric discharge in normal industrial environments.

NOTE 3 It is acknowledged that, with developments in technology, it may be possible to achieve the objectives of the IEC 60079 series of standards in respect of explosion prevention by methods that are not yet fully defined. Where a manufacturer wishes to take advantage of such developments, this International Standard, as well as other standards in the IEC 60079 series, may be applied in part. It is intended that the manufacturer prepare documentation that clearly defines how the IEC 60079 series of standards has been applied, together with a full explanation of the additional techniques employed. The designation "Ex s" has been reserved to indicate special protection. A standard for special protection "s", IEC 60079-33, is in preparation.

NOTE 4 Where an explosive gas atmosphere and a combustible dust atmosphere are, or may be, present at the same time, the simultaneous presence of both should be considered and may require additional protective measures.

This standard does not specify requirements for safety, other than those directly related to the explosion risk. Ignition sources like adiabatic compression, shock waves, exothermic chemical reaction, self ignition of dust, naked flames and hot gases/liquids, are not addressed by this standard.

NOTE 5 Such equipment should be subjected to a hazard analysis that identifies and lists all of the potential sources of ignition by the electrical equipment and the measures to be applied to prevent them becoming effective.

This standard is supplemented or modified by the following standards concerning specific types of protection:

- IEC 60079-1: Gas – Flameproof enclosures "d";
- IEC 60079-2: Gas – Pressurized enclosures "p";

- IEC 60079-5: Gas – Powder filling "q";
- IEC 60079-6: Gas – Oil immersion "o";
- IEC 60079-7: Gas – Increased safety "e";
- IEC 60079-11: Gas – Intrinsic safety "i";
- IEC 60079-15: Gas – Type of protection "n";
- IEC 60079-18: Gas and dust – Encapsulation "m";
- IEC 60079-31: Dust – Protection by enclosure "t"
- IEC 61241-4: Dust – Pressurization "pD".

NOTE 6 Additional information on types of protection for non-electrical equipment can be found in ISO/IEC 80079-36 (to be published).

This standard is supplemented or modified by the following equipment standards:

IEC 60079-13: Explosive atmospheres – Part 13: Equipment protection by pressurized room "p"

IEC 60079-25: Explosive atmospheres – Part 25: Intrinsically safe electrical systems

IEC 60079-26: Explosive atmospheres – Part 26: Equipment with equipment protection level (EPL) Ga

IEC 60079-28: Explosive atmospheres – Part 28: Protection of equipment and transmission systems using optical radiation

IEC 62013-1: Caplights for use in mines susceptible to firedamp – Part 1: General requirements – Construction and testing in relation to the risk of explosion

IEC 60079-30-1: Explosive atmospheres – Part 30-1: Electrical resistance trace heating – General and testing requirements.

This standard with the additional standards mentioned above, are not applicable to the construction of

- electromedical apparatus,
- shot-firing exploders,
- test devices for exploders, and
- shot-firing circuits.

2 Normative references

The following referenced documents are indispensable for the application of this document. For dated references, only the edition cited applies. For undated references, the latest edition of the referenced document (including any amendments) applies.

☐ EN 1710, *Equipment and components intended for use in potentially explosive atmospheres in underground mines*

EN 14986, *Design of fans working in potentially explosive atmospheres* ☐

IEC 60034-1, *Rotating electrical machines – Part 1: Rating and performance*

IEC 60034-5, *Rotating electrical machines – Part 5: Classification of degrees of protection provided by the enclosures of rotating electrical machines (IP Code)*

IEC 60050-426, *International Electrotechnical Vocabulary (IEV) – Chapter 426: Electrical apparatus for explosive atmospheres*

IEC 60079-1, *Explosive atmospheres – Part 1: Equipment protection by flameproof enclosure "d"*

IEC 60079-2, *Explosive atmospheres – Part 2: Equipment protection by pressurized enclosures "p"*

IEC 60079-5, *Explosive atmospheres – Part 5: Equipment protection by powder filling "q"*

IEC 60079-6, *Explosive atmospheres – Part 6: Equipment protection by oil-immersion "o"*

IEC 60079-7, *Explosive atmospheres – Part 7: Equipment protection by increased safety "e"*

IEC 60079-11, *Explosive atmospheres – Part 11: Equipment protection by intrinsic safety "i"*

IEC 60079-15, *Explosive atmospheres – Part 15: Equipment protection by type of protection "n"*

IEC 60079-18, *Explosive atmospheres – Part 18: Equipment protection by encapsulation "m"*

IEC 60079-20-1, *Explosive Atmosphere – Part 20-1: Material characteristics for gas and vapour classification, test methods and data*

IEC 60079-25: *Explosive atmospheres – Part 25: Intrinsically safe systems*

IEC 60079-26: *Explosive atmospheres – Part 26: Equipment with equipment protection level (EPL) Ga*

IEC 60079-28: *Explosive atmospheres – Part 28: Protection of equipment and transmission systems using optical radiation*

IEC 60079-30-1: *Explosive atmospheres – Part 30-1: Electrical resistance trace heating – General and testing requirements*

IEC 60079-31, *Explosive atmospheres – Part 31: Equipment dust ignition protection by enclosures "t"*

IEC 60086-1, *Primary batteries – Part 1: General*

IEC 60095-1, *Lead-acid starter batteries – Part 1: General requirements and methods of test*

IEC 60192, *Low-pressure sodium vapour lamps – Performance specifications*

IEC 60216-1, *Electrical insulating materials – Properties of thermal endurance – Part 1: Ageing procedures and evaluation of test results*

IEC 60216-2, *Electrical insulating materials – Thermal endurance properties – Part 2: Determination of thermal endurance properties of electrical insulating materials – Choice of test criteria*

IEC 60243-1, *Electrical strength of insulating materials – Test methods – Part 1: Tests at power frequencies*

IEC 60254 (all parts), *Lead-acid traction batteries*

<http://www.china-gauges.com/>

IEC 60423, *Conduits for electrical purposes – Outside diameters of conduits for electrical installations and threads for conduits and fittings*

IEC 60529, *Degrees of protection provided by enclosures (IP Code)*

IEC 60622, *Secondary cells and batteries containing alkaline or other non-acid electrolytes – Sealed nickel-cadmium prismatic rechargeable single cells*

IEC 60623, *Secondary cells and batteries containing alkaline or other non-acid electrolytes – Vented nickel-cadmium prismatic rechargeable single cells*

IEC 60662, *High-pressure sodium vapour lamps*

IEC 60664-1, *Insulation coordination for equipment within low-voltage systems – Part 1: Principles, requirements and tests*

IEC 60947-1, *Low-voltage switchgear and controlgear – Part 1: General rules*

IEC 60896-11, *Stationary lead-acid batteries – Part 11: Vented types – General requirements and methods of tests*

IEC 60896-21, *Stationary lead-acid batteries – Part 21: Valve regulated types – Methods of test*

IEC 60952 (all parts), *Aircraft batteries*

IEC 61056-1, *General purpose lead-acid batteries (valve-regulated types) – Part 1: General requirements, functional characteristics – Methods of tests*

IEC 61241-4, *Electrical apparatus for use in the presence of combustible dust – Part 4: Type of protection “pD”*

IEC 61427, *Secondary cells and batteries for photovoltaic energy systems (PVES) – General requirements and methods of test*

IEC 61951-1, *Secondary cells and batteries containing alkaline and other non-acid electrolytes – Portable sealed rechargeable single cells – Part 1: Nickel-cadmium*

IEC 61951-2, *Secondary cells and batteries containing alkaline and other non-acid electrolytes – Portable sealed rechargeable single cells – Part 2: Nickel-metal hydride*

IEC 61960, *Secondary cells and batteries containing alkaline or other non-acid electrolytes – Secondary lithium cells and batteries for portable applications*

IEC 62013-1, *Caplights for use in mines susceptible to firedamp – Part 1: General requirements – Construction and testing in relation to the risk of explosion*

ISO 178, *Plastics – Determination of flexural properties*

ISO 179 (all parts), *Plastics – Determination of Charpy impact properties*

ISO 262, *ISO general-purpose metric screw threads – Selected sizes for screws, bolts and nuts*

ISO 273, *Fasteners – Clearance holes for bolts and screws*

ISO 286-2, *ISO system of limits and fits – Part 2: Tables of standard tolerance grades and limit deviations for holes and shafts*

ISO 527-2, *Plastics – Determination of tensile properties – Part 2: Test conditions for moulding and extrusion plastics*

ISO 965-1, *ISO general-purpose metric screw threads – Tolerances – Part 1: Principles and basic data*

ISO 965-3, *ISO general-purpose metric screw threads – Tolerances – Part 3: Deviations for constructional screw threads*

ISO 1817, *Rubber, vulcanized – Determination of the effect of liquids*

ISO 3601-1, *Fluid power systems – O-rings – Part 1: Inside diameters, cross-sections, tolerances and designation codes*

ISO 3601-2, *Fluid power systems – O-rings – Part 2: Housing dimensions for general applications*

ISO 4014, *Hexagon head bolts – Product grades A and B*

ISO 4017, *Hexagon head screws – Product grades A and B*

ISO 4026, *Hexagon socket set screws with flat point*

ISO 4027, *Hexagon socket set screws with cone point*

ISO 4028, *Hexagon socket set screws with dog point*

ISO 4029, *Hexagon socket set screws with cup point*

ISO 4032, *Hexagon nuts, style 1 – Product grades A and B*

ISO 4762, *Hexagon socket head cap screws*

ISO 4892-2, *Plastics – Methods of exposure to laboratory light sources – Part 2: Xenon-arc lamps*

ISO 7380, *Hexagon socket button head screws*

ISO 14583, *Hexalobular socket pan head screws*

ANSI/UL 746B, *Polymeric Materials – Long-Term Property Evaluations*

ANSI/UL 746C, *Polymeric Materials – Used in Electrical Equipment Evaluations*

3 Terms and definitions

For the purposes of this document, the following terms and definitions apply.

NOTE For the definitions of any other terms, particularly those of a more general nature, reference should be made to IEC 60050(426) or other appropriate parts of the IEV (International Electrotechnical Vocabulary).

3.1

ambient temperature

temperature of the air or other media, in the immediate vicinity of the equipment or component

NOTE This does not refer to the temperature of any process media, unless the equipment or component is totally immersed in the process media. See 5.1.1.

3.2

area, hazardous

area in which an explosive atmosphere is present, or may be expected to be present, in quantities such as to require special precautions for the construction, installation and use of electrical apparatus

3.3

area, non-hazardous

area in which an explosive atmosphere is not expected to be present in quantities such as to require special precautions for the construction, installation and use of electrical apparatus

3.4

associated apparatus

electrical apparatus which contains both energy-limited and non-energy-limited circuits and is constructed so that the non-energy-limited circuits cannot adversely affect the energy-limited circuits

NOTE Associated apparatus may be either:

- a) electrical apparatus which has an alternative type of protection included in this standard for use in the appropriate explosive atmosphere;
- b) electrical apparatus not so protected and which therefore is not to be used within an explosive atmosphere, for example, a recorder which is not of itself in an explosive atmosphere but is connected to a thermocouple situated within an explosive atmosphere where only the recorder input circuit is energy limited.

3.5

cells and batteries

3.5.1

battery

assembly of two or more cells electrically connected to each other to increase the voltage or capacity

3.5.2

capacity

quantity of electricity or electric charge, which a fully charged battery can deliver under specified conditions

3.5.3

cell

assembly of electrodes and electrolyte which constitutes the smallest electrical unit of a battery

3.5.4

charging

act of forcing current through a secondary cell or battery in the opposite direction to the normal flow to restore the energy

3.5.5

deep discharge

event which reduces a cell voltage below that recommended by the cell or battery manufacturer

3.5.6

maximum open-circuit voltage (of a cell or battery)

maximum attainable voltage under normal conditions, that is, from either a new primary cell, or a secondary cell just after a full charge

NOTE See Tables 11 and 12 which show the maximum open-circuit voltage for acceptable cells.

3.5.7

nominal voltage

(of a cell or battery) is that specified by the manufacturer

3.5.8

vented cell or battery

secondary cell, or battery, having a cover provided with an opening through which gaseous products may escape

3.5.9

primary cell or battery

electrochemical system capable of producing electrical energy by chemical reaction

3.5.10

reverse charging

act of forcing current through either a primary cell or secondary cell in the same direction as the normal flow, for example, in an expired battery

3.5.11

sealed gas-tight cell or battery

cell or battery which remains closed and does not release either gas or liquid when operated within the limits of charge or temperature specified by the manufacturer

NOTE 1 Such cells and batteries may be equipped with a safety device to prevent dangerously high internal pressure. The cell or battery does not require addition to the electrolyte and is designed to operate during its life in its original sealed state.

NOTE 2 The above definition is taken from IEC 60079-11. It differs from the definitions in IEC 486-01-20 and IEC 486-01-21 by virtue of the fact that it applies to either a cell or battery.

3.5.12

sealed valve-regulated cell or battery

cell or battery which is closed under normal conditions but which has an arrangement which allows the escape of gas if the internal pressure exceeds a pre-determined value. The cell cannot normally receive an addition to the electrolyte

3.5.13

secondary cell or battery

electrically rechargeable electrochemical system capable of storing electrical energy and delivering it by chemical reaction

3.5.14

container (battery)

enclosure to contain the battery

NOTE The cover is a part of the battery container.

3.6

bushing

insulating device carrying one or more conductors through an internal or external wall of an enclosure

3.7

cable gland

device permitting the introduction of one or more electric and/or fibre optic cables into an electrical equipment so as to maintain the relevant type of protection

3.7.1

clamping device

element of a cable gland for preventing tension or torsion in the cable from being transmitted to the connections

3.7.2

compression element

element of a cable gland acting on the sealing ring to enable the latter to fulfil its function

3.7.3

sealing ring

ring used in a cable gland to ensure the sealing between the cable gland and the cable

3.7.4

Ex Equipment cable gland

cable gland tested separately from the equipment enclosure but certified as equipment and which can be fitted to the equipment enclosure during installation.

3.7.5

cable transit device

an entry device, intended for one or more cables, with a seal made up of one or more separate elastomeric modules or parts of modules (modular internal seal), which are compressed together when the device is assembled and mounted as intended.

NOTE Cable transit devices can also serve as Ex blanking Elements when the elastomeric modules provided allow for this function.

3.8

certificate

document that assures the conformity of a product, process, system, person, or organization with specified requirements

NOTE The certificate may be either the supplier's declaration of conformity or the purchaser's recognition of conformity or certification (as a result of action by a third party) as defined in ISO/IEC 17000.

3.8.1

Ex Component Certificate

a certificate prepared for an Ex Component. See 3.28.

3.8.2

Equipment Certificate

A certificate prepared for equipment other than an Ex Component. Such equipment may include Ex Components, but additional evaluation is always required as part of their incorporation into equipment. See 3.7.4, 3.25, 3.27, 3.28, and 3.29.

3.9

compound (for encapsulation)

any thermosetting, thermoplastic, epoxy resin or elastomeric materials with or without fillers and/or additives, in their solid state; used for encapsulation

3.10

conduit entry

means of introducing a conduit into electrical equipment so as to maintain the relevant type of protection

3.11

connection facilities

terminals, screws or other parts, used for the electrical connection of conductors of external circuits

3.12

connections, factory

terminations intended for connection during a manufacturing process, under controlled conditions

3.13

connections, field-wiring

terminations intended for connection by the installer in the field

3.14

continuous operating temperature COT

temperature range which ensures the stability and integrity of the material for the expected life of the equipment, or part, in its intended application

3.15

converter (for use with electrical machines)

unit for electronic power conversion, changing one or more electrical characteristics and comprising one or more electronic switching devices and associated components, such as transformers, filters, commutation aids, controls, protections, and auxiliaries, if any

NOTE A Converter may also be known as a frequency converter, a converter drive, an inverter drive, a variable speed drive, or a variable frequency drive.

3.16

converter, soft-start

converter which limits the input current to the electrical machine during the starting process.

NOTE It is intended that the soft-start converter is used only during the starting process and is then isolated from the power system when the electrical machine is running.

3.17

degree of protection of enclosure

IP

numerical classification according to IEC 60529 preceded by the symbol IP applied to the enclosure of electrical equipment to provide

- protection of persons against contact with, or approach to, live parts and against contact with moving parts (other than smooth rotating shafts and the like) inside the enclosure,
- protection of the electrical equipment against ingress of solid foreign objects, and
- where indicated by the classification, protection of the electrical equipment against harmful ingress of water

NOTE 1 The detailed test requirements for rotating electrical machines are in IEC 60034-5.

NOTE 2 The enclosure which provides the degree of protection IP is not necessarily identical to the equipment enclosure for the types of protection listed in the Foreword.

3.18

dust

generic term including both combustible dust and combustible flyings

3.18.1

combustible dust

finely divided solid particles, 500 µm or less in nominal size, which may be suspended in air, may settle out of the atmosphere under their own weight, may burn or glow in air, and may form explosive mixtures with air at atmospheric pressure and normal temperatures

NOTE 1 This includes dust and grit as defined in ISO 4225.

NOTE 2 The term solid particles is intended to address particles in the solid phase and not the gaseous or liquid phase, but does not preclude a hollow particle.

3.18.1.1

conductive dust

combustible dust with electrical resistivity equal to or less than $10^3 \Omega \cdot m$

NOTE IEC 61241-2-2 contains the test method for determining the electrical resistivity of dusts.

3.18.1.2

non-conductive dust

combustible dust with electrical resistivity greater than $10^3 \Omega \cdot m$

NOTE IEC 61241-2-2 contains the test method for determining the electrical resistivity of dusts.

3.18.2

combustible flyings

solid particles, including fibres, greater than 500 µm in nominal size which may be suspended in air and could settle out of the atmosphere under their own weight

NOTE Examples of flyings include rayon, cotton (including cotton linters and cotton waste), sisal, jute, hemp, cocoa fibre, oakum, and baled waste kapok.

3.19

dust-tight enclosure

enclosure capable of excluding the ingress of observable dust particle deposits

3.20

dust-protected enclosure

enclosure in which the ingress of dust is not totally excluded, but is unlikely to enter in sufficient quantity to interfere with the safe operation of the equipment and does not accumulate in a position within the enclosure where it is liable to cause an ignition hazard

3.21

elastomer

a macromolecular material which returns rapidly to approximately its initial dimensions and shape after substantial deformation by a weak stress and release of the stress (IEV 212-04-05)

NOTE The definition applies to room temperature test conditions.

3.22

electrical equipment

items applied as a whole or in part for the utilization of electrical energy

NOTE These include, amongst others, items for the generation, transmission, distribution, storage, measurement, regulation, conversion and consumption of electrical energy and items for telecommunications.

3.23

encapsulation

process of applying a compound to enclose an electrical device(s) by suitable means

3.24

enclosure

all the walls, doors, covers, cable glands, rods, spindles, shafts, etc. which contribute to the type of protection and/or the degree of protection IP of the electrical equipment

3.25

equipment (for explosive atmospheres)

general term including apparatus, fittings, devices, components, and the like used as a part of, or in connection with, an electrical installation in an explosive atmosphere

3.26

equipment protection level

EPL

level of protection assigned to equipment based on its likelihood of becoming a source of ignition and distinguishing the differences between explosive gas atmospheres, explosive dust atmospheres, and the explosive atmospheres in mines susceptible to firedamp

NOTE The equipment protection level may optionally be employed as part of a complete risk assessment of an installation, see IEC 60079-14.

3.26.1

EPL Ma

equipment for installation in a mine susceptible to firedamp, having a "very high" level of protection, which has sufficient security that it is unlikely to become an ignition source in normal operation, during expected malfunctions or during rare malfunctions, even when left energized in the presence of an outbreak of gas

3.26.2

EPL Mb

equipment for installation in a mine susceptible to firedamp, having a "high" level of protection, which has sufficient security that it is unlikely to become a source of ignition in normal operation or during expected malfunctions in the time span between there being an outbreak of gas and the equipment being de-energized

3.26.3

EPL Ga

equipment for explosive gas atmospheres, having a "very high" level of protection, which is not a source of ignition in normal operation, during expected malfunctions or during rare malfunctions

3.26.4

EPL Gb

equipment for explosive gas atmospheres, having a "high" level of protection, which is not a source of ignition in normal operation or during expected malfunctions

3.26.5

EPL Gc

equipment for explosive gas atmospheres, having an "enhanced" level of protection, which is not a source of ignition in normal operation and which may have some additional protection to ensure that it remains inactive as an ignition source in the case of regular expected occurrences (for example failure of a lamp)

3.26.6

EPL Da

equipment for explosive dust atmospheres, having a "very high" level of protection, which is not a source of ignition in normal operation, during expected malfunctions, or during rare malfunctions

3.26.7

EPL Db

equipment for explosive dust atmospheres, having a "high" level of protection, which is not a source of ignition in normal operation or during expected malfunctions

3.26.8

EPL Dc

equipment for explosive dust atmospheres, having an "enhanced" level of protection, which is not a source of ignition in normal operation and which may have some additional protection to ensure that it remains inactive as an ignition source in the case of regular expected occurrences (for example failure of a lamp)

3.27

Ex blanking element

threaded blanking element tested separately from the equipment enclosure but having an equipment certificate and which is intended to be fitted to the equipment enclosure without further consideration

NOTE 1 This does not preclude an Ex Component certificate for blanking elements

NOTE 2 Non-threaded blanking elements are not equipment.

3.28

Ex Component

part of electrical equipment or a module, marked with the symbol "U", which is not intended to be used alone and requires additional consideration when incorporated into electrical equipment or systems for use in explosive atmospheres

3.29

Ex thread adapter

thread adapter tested separately from the enclosure but having an equipment certificate and which is intended to be fitted to the equipment enclosure without further consideration

NOTE This does not preclude an Ex Component certificate for thread adapters.

3.30

explosive atmosphere

mixture with air, under atmospheric conditions, of flammable substances in the form of gas, vapour, dust, fibres, or flyings which, after ignition, permits self-sustaining propagation

3.31

explosive dust atmosphere

mixture with air, under atmospheric conditions, of flammable substances in the form of dust, fibres, or flyings which, after ignition, permits self-sustaining propagation

3.32

explosive gas atmosphere

mixture with air, under atmospheric conditions, of flammable substances in the form of gas or vapour, which, after ignition, permits self-sustaining flame propagation

3.33

explosive test mixture

specified explosive mixture used for the testing of electrical equipment for explosive gas atmospheres

3.34

firedamp

flammable mixture of gases naturally occurring in a mine

NOTE Firedamp consists mainly of methane, but always contains small quantities of other gases, such as nitrogen, carbon dioxide, and hydrogen, and sometimes ethane and carbon monoxide. The terms firedamp and methane are used frequently in mining practice as synonyms.

3.35
free space

intentionally created space surrounding components or space inside components

3.36
galvanic isolation

arrangement within equipment which permits the transfer of signals or power between two circuits without any direct electrical connection between the two

NOTE Galvanic isolation frequently utilizes either magnetic (transformer or relay) or opto-coupled elements.

3.37
ignition temperature of an explosive gas atmosphere

lowest temperature of a heated surface which, under specified conditions according to IEC 60079-20-1, will ignite a flammable substance in the form of a gas or vapour mixture with air

3.38
ignition temperature of a dust layer

lowest temperature of a hot surface at which ignition occurs in a dust layer of specified thickness on a hot surface

NOTE The ignition temperature of a dust layer may be determined by the test method given in IEC 61241-2-1.

3.39
ignition temperature of a dust cloud

lowest temperature of the hot inner wall of a furnace at which ignition occurs in a dust cloud in air contained therein

NOTE The ignition temperature of a dust cloud may be determined by the test method given in IEC 61241-2-1.

3.40
limiting temperature

maximum permissible temperature for equipment or parts of equipment equal to the lower of the two temperatures determined by:

- a) the danger of ignition of the explosive atmosphere;
- b) the thermal stability of the materials used

3.41
malfunction

equipment or components which do not perform their intended function with respect to explosion protection

NOTE For the purposes of this standard this can happen due to a variety of reasons, including:

- failure of one (or more) of the component parts of the equipment or components;
- external disturbances (e.g. shocks, vibration, electromagnetic fields);
- design error or deficiency (e.g. software errors);
- disturbance of the power supply or other services;
- loss of control by the operator (especially for handheld equipment).

3.41.1
expected malfunction

disturbances or equipment malfunctions which normally occur in practice

3.41.2

rare malfunction

type of malfunction, which may happen, but only in rare instances. Two independent expected malfunctions which, separately, would not create a source of ignition, but which, in combination, do create a source of ignition, are regarded as a single rare malfunction

3.42

maximum surface temperature

highest temperature which is attained in service under the most adverse conditions (but within the specified tolerances) by any part or surface of electrical equipment

NOTE 1 For electrical equipment in an explosive gas atmosphere, this temperature may occur on an internal component or on the external surface of the enclosure, depending upon the type of protection employed.

NOTE 2 For electrical equipment in an explosive dust atmosphere, this temperature occurs on the external surface of the enclosure and may include a defined dust layer condition.

3.43

normal operation

operation of equipment conforming electrically and mechanically with its design specification and used within the limits specified by the manufacturer

NOTE 1 The limits specified by the manufacturer may include persistent operational conditions, e.g. operation of a motor on a duty cycle.

NOTE 2 Variation of the supply voltage within stated limits and any other operational tolerance is part of normal operation.

3.44

level of protection

subdivision of a Type of Protection, correlating with the Equipment Protection Level, that differentiates the likelihood of the equipment becoming a source of ignition

NOTE For example, Type of Protection intrinsic safety "i" is subdivided into Levels of Protection "ia", "ib", and "ic"; which correlate with Equipment Protection Levels Ga, Gb, and Gc (for explosive gas atmospheres).

3.45

plastic

a material which contains as an essential ingredient a high polymer and which at some stage in its processing into finished products can be shaped by flow

[IEV 212-04-02]

NOTE Elastomers, which are also shaped by flow, are not considered as plastics.

3.46

radio frequency

electromagnetic waves from 9 kHz to 60 GHz

3.46.1

continuous transmission

transmission where the duration of the pulse is greater than the half of the thermal initiation time

3.46.2

pulsed transmission

transmission where the duration of the pulse is shorter than the half of the thermal initiation time, but the time between two consecutive pulses, however, is longer than three times the thermal initiation time

3.46.3

thermal initiation time

time (over which the threshold power is averaged) during which energy deposited by the spark accumulates in a small volume of gas around it without significant thermal dissipation

NOTE For times shorter than the thermal initiation time the total energy deposited by the spark will determine whether or not ignition occurs. For increasingly longer times, the power or rate at which energy is deposited becomes the determining factor for ignition.

3.46.4

threshold energy

Z_{th}

for a pulsed radio-frequency discharge, the maximum energy of the single pulse which can be extracted from the receiving body

3.46.5

threshold power

P_{th}

product of the effective output power of the transmitter multiplied by the antenna gain

NOTE The gain is produced by an antenna concentrating radiation in a particular direction and is always related to a specified reference antenna

3.47

rated value

quantity value, assigned generally by the manufacturer, for a specified operating condition of a component, device or apparatus

3.48

rating

set of rated values and operating conditions

3.49

replaceable battery pack

assembly consisting of one or more interconnected cells, along with any integrated protective components, which form a complete replaceable battery

3.50

service temperature

maximum or minimum temperature reached at specific points of the equipment when the equipment is operating at rated conditions, including ambient temperature and any external sources of heating or cooling. See 5.2

NOTE Equipment may reach different service temperatures in different parts.

3.51

spacings, electrical

separation distances between conductive parts at different electrical potentials

3.51.1

clearance

shortest distance in air between two conductive parts

3.51.2

creepage distance

shortest distance along the surface of a solid insulating material between two conductive parts

3.51.3

distance through casting compound

shortest distance through a casting compound between two conductive parts

3.51.4

distance through solid insulation

shortest distance through solid insulation between two conductive parts

3.51.5

distance under coating

shortest distance between conductive parts along the surface of an insulating medium covered with insulating coating

3.52

symbol “U”

symbol used to denote an EFL component

NOTE The symbol “U” is used to identify that the equipment is incomplete and is not suitable for installation without further evaluation.

3.53

symbol “X”

symbol used to denote specific conditions of use

NOTE The symbol “X” is used to provide a means of identifying that essential information for the installation, use, and maintenance of the equipment is contained within the certificate.

3.54

termination compartment

separate compartment, or part of a main enclosure, communicating or not with the main enclosure, and containing connection facilities

3.55

test, routine

test to which each individual device is subjected during or after manufacture to ascertain whether it complies with certain criteria

3.56

test, type

test of one or more devices made to a certain design to show that the design meets certain specifications

3.57

type of protection

specific measures applied to electrical equipment to avoid ignition of a surrounding explosive atmosphere

3.58

void

unintentional space created as a consequence of the encapsulation process

3.59

working voltage

highest r.m.s. value of the a.c. or d.c. voltage across any particular insulation which can occur when the equipment is supplied at rated voltage

NOTE 1 Transients are disregarded.

NOTE 2 Both open-circuit conditions and normal operating conditions are taken into account.

<http://www.china-gauges.com/>

4 Equipment grouping

Electrical equipment for explosive atmospheres is divided into the following groups:

4.1 Group I

Electrical equipment of Group I is intended for use in mines susceptible to firedamp.

NOTE The types of protection for Group I take into account the ignition of both firedamp and coal dust along with enhanced physical protection for equipment used underground.

Electrical equipment intended for mines where the atmosphere, in addition to firedamp, may contain significant proportions of other flammable gases (i.e. other than methane), shall be constructed and tested in accordance with the requirements relating to Group I and also to the subdivision of Group II corresponding to the other significant flammable gases. This electrical equipment shall then be marked appropriately (for example, "Ex d I/II B T3" or "Ex d I/II (NH₃)").

4.2 Group II

Electrical equipment of Group II is intended for use in places with an explosive gas atmosphere other than mines susceptible to firedamp.

Electrical equipment of Group II is subdivided according to the nature of the explosive gas atmosphere for which it is intended.

Group II subdivisions

- IIA, a typical gas is propane
- IIB, a typical gas is ethylene
- IIC, a typical gas is hydrogen

NOTE 1 This subdivision is based on the maximum experimental safe gap (MESG) or the minimum ignition current ratio (MIC ratio) of the explosive gas atmosphere in which the equipment may be installed. (See IEC 60079-20-1).

NOTE 2 Equipment marked IIB is suitable for applications requiring Group IIA equipment. Similarly, equipment marked IIC is suitable for applications requiring Group IIA or Group IIB equipment.

4.3 Group III

Electrical equipment of Group III is intended for use in places with an explosive dust atmosphere other than mines susceptible to firedamp.

Electrical equipment of Group III is subdivided according to the nature of the explosive dust atmosphere for which it is intended.

Group III subdivisions:

- IIIA: combustible flyings
- IIIB: non-conductive dust
- IIIC: conductive dust

NOTE Equipment marked IIIB is suitable for applications requiring Group IIIA equipment. Similarly, equipment marked IIIC is suitable for applications requiring Group IIIA or Group IIIB equipment.

4.4 Equipment for a particular explosive atmosphere

The electrical equipment may be tested for a particular explosive atmosphere. In this case, the information shall be recorded on the certificate and the electrical equipment marked accordingly.

5 Temperatures

5.1 Environmental influences

5.1.1 Ambient temperature

Electrical equipment designed for use in a normal ambient temperature range of -20 °C to $+40\text{ °C}$ does not require marking of the ambient temperature range. However, electrical equipment designed for use in other than this normal ambient temperature range is considered to be special. The marking shall then include either the symbol T_a or T_{amb} together with both the upper and lower ambient temperatures or, if this is impracticable, the symbol “X” shall be used to indicate specific conditions of use that include the upper and lower ambient temperatures. See item e) of 29.3 and Table 1.

NOTE The ambient temperature range may be a reduced range, e.g. $-5\text{ °C} \leq T_{amb} \leq 15\text{ °C}$.

Table 1 – Ambient temperatures in service and additional marking

Electrical equipment	Ambient temperature in service	Additional marking
Normal	Maximum: $+40\text{ °C}$ Minimum: -20 °C	None
Special	Specified by the manufacturer	T_a or T_{amb} with the special range, for example, $-30\text{ °C} \leq T_a \leq +40\text{ °C}$ or the symbol “X”

5.1.2 External source of heating or cooling

Where the electrical equipment is intended to be physically connected to a separate external source of heating or cooling, such as a heated or cooled process vessel or pipeline, the ratings of the external source shall be specified in the certificate and in the manufacturer's instructions.

NOTE 1 The external source of heating or cooling is frequently referred to as the “process temperature”.

NOTE 2 The way in which these ratings are expressed will vary according to the nature of the source. For sources generally larger than the equipment, the maximum or minimum temperature will usually be sufficient. For sources generally smaller than the equipment, or for heat conduction through thermal insulation, the rate of heat flow may be appropriate.

NOTE 3 The influence of radiated heat may need to be considered on the final installation. See IEC 60079-14.

5.2 Service temperature

Where this standard, or the standard for the specific type of protection, requires the service temperature to be determined at any place in the equipment, the temperature shall be determined for the rating of the electrical equipment when the equipment is subjected to maximum or minimum ambient temperature and, where relevant, the maximum rated external source of heating or cooling. Service temperature testing, when required, shall be in accordance with 26.5.1.

NOTE The rating of the electrical equipment includes the ambient temperature, the electrical supply and load, duty cycle or duty type, as assigned by the manufacturer, typically as shown in the marking.

5.3 Maximum surface temperature

5.3.1 Determination of maximum surface temperature

Maximum surface temperature shall be determined according to 26.5.1 considering the maximum ambient temperature and, where relevant, the maximum rated external source of heating.

5.3.2 Limitation of maximum surface temperature

5.3.2.1 Group I electrical equipment

For electrical equipment of Group I, the maximum surface temperature shall be specified in relevant documentation according to Clause 24.

This maximum surface temperature shall not exceed

- 150 °C on any surface where coal dust can form a layer,
- 450 °C where coal dust is not likely to form a layer (i.e., inside of a dust-protected enclosure).

NOTE When choosing Group I electrical equipment, the user should take into account the influence and the smouldering temperature of coal dusts if they are likely to be deposited in a layer on surfaces with temperatures above 150 °C.

5.3.2.2 Group II electrical equipment

The maximum surface temperature determined (see 26.5.1) shall not exceed:

- the temperature class assigned (see Table 2), or
- the maximum surface temperature assigned, or
- if appropriate, the ignition temperature of the specific gas for which it is intended.

Table 2 – Classification of maximum surface temperatures for Group II electrical equipment

Temperature class	Maximum surface temperature
	°C
T1	450
T2	300
T3	200
T4	135
T5	100
T6	85

NOTE More than one temperature class may be established for different ambient temperatures and different external sources of heating and cooling.

5.3.2.3 Group III electrical equipment

5.3.2.3.1 Maximum surface temperature determined without a dust layer

The maximum surface temperature determined (see 26.5.1) shall not exceed the maximum surface temperature assigned.

5.3.2.3.2 Maximum surface temperature with respect to dust layers

In addition to the maximum surface temperature required in 5.3.2.3.1, the maximum surface temperature may also be determined for a given depth of layer, T_L , of dust surrounding all sides of the equipment, unless otherwise specified in the documentation, and marked with the symbol “X” to indicate this specific condition of use in accordance with item d) of 29.5.

NOTE 1 A maximum depth of layer, T_L , may be specified by the manufacturer.

NOTE 2 Additional information on the application of equipment where dust layers up to 50 mm may accumulate on the equipment is given in IEC 60079-14.

5.3.3 Small component temperature for Group I or Group II electrical equipment

NOTE There is both theoretical and practical evidence to show that the smaller the heated surface, the higher the surface temperature required to ignite a given explosive atmosphere.

Small components, for example transistors or resistors, whose temperature exceeds that permitted for the temperature classification, shall be acceptable providing that they conform to one of the following:

- when tested in accordance with 23.3.3, small components shall not cause ignition of the flammable mixture and any deformation or deterioration caused by the higher temperature shall not impair the type of protection; or
- for T4 and Group I classification, small components shall conform to Table 3a and Table 3b; or
- for T5 classification, the surface temperature of a component with a surface area smaller than 1 000 mm² (excluding lead wires) shall not exceed 150 °C.

Table 3a – Assessment of temperature classification according to component size at 40 °C ambient temperature

Total surface area excluding lead wires	Equipment Group II		Equipment Group I	
	With temperature class T4		Dust excluded	
	Maximum surface temperature	Maximum power dissipation	Maximum surface temperature	Maximum power dissipation
	°C	W	°C	W
<20 mm ²	275		950	
≥20 mm ² ≤1 000 mm ²	200, or	1,3		3,3
>1 000 mm ²		1,3		3,3

**Table 3b – Assessment of temperature classification
Component surface area ≥ 20 mm²
Variation in maximum power dissipation with ambient temperature**

Maximum ambient temperature	°C	Equipment group	40	50	60	70	80
Maximum power dissipation	W	Group II	1,3	1,25	1,2	1,1	1,0
		Group I	3,3	3,22	3,15	3,07	3,0

For potentiometers, the surface to be considered shall be that of the resistance element and not the external surface of the component. The mounting arrangement and the heat-sinking and cooling effect of the overall potentiometer construction shall be taken into consideration during the test. Temperature shall be measured on the track with that current which flows under the test conditions required by the standard for the specific type of protection. If this results in a resistance value of less than 10 % of the track resistance value, the measurements shall be carried out at 10 % of the track resistance value.

For surface areas of not more than 1 000 mm², the surface temperature may exceed that for the temperature class marked on the Group II electrical equipment or the corresponding

maximum surface temperature for Group I electrical equipment, if there is no risk of ignition from these surfaces, with a safety margin of

- 50 K for T1, T2 and T3,
- 25 K for T4, T5 and T6 and Group I.

This safety margin shall be ensured by experience of similar components or by tests of the electrical equipment itself in representative explosive mixtures.

NOTE During the tests, the safety margin may be provided by increasing the ambient temperature or by increasing the power dissipation of the component. For methane, the second option is recommended.

6 Requirements for all electrical equipment

6.1 General

Electrical equipment and Ex Components shall

- a) comply with the requirements of this standard, together with one or more of the specific standards listed in Clause 1, and

NOTE 1 These specific standards may vary the requirements of this standard.

NOTE 2 All of the requirements for cable glands marked as type of protection “e” are located in IEC 60079-0.

- b) be constructed in accordance with the applicable safety requirements of the relevant industrial standards.

NOTE 3 It is not a requirement of this standard that compliance with these industrial standards be verified.

NOTE 4 If the electrical equipment or Ex Component is intended to withstand particularly adverse service conditions (for example, rough handling, humidity effects, ambient temperature variations, effects of chemical agents, corrosion), these should be specified to the manufacturer by the user. If certification is sought, it is not a requirement of this standard that the certification body confirm suitability for the adverse conditions. Special precautions should be taken when vibration effects on terminals, fuse holders, lampholders and current-carrying connections in general may impair safety, unless they comply with specific standards.

6.2 Mechanical strength of equipment

The equipment shall be subjected to the tests of 26.4. Guards relied upon to provide protection from impact shall be removable only by the use of a tool and shall remain in place for the required impact tests.

6.3 Opening times

Enclosures which can be opened more quickly than

- a) any incorporated capacitors, charged by a voltage of 200 V or more, to discharge to a value of residual energy of
 - 0,2 mJ for electrical equipment of Group I or Group IIA,
 - 0,06 mJ for electrical equipment of Group IIB,
 - 0,02 mJ for electrical equipment of Group IIC, including equipment marked Group II only,
 - 0,2 mJ for electrical equipment of Group III,

or double the above energy levels if the charging voltage is less than 200 V, or

- b) the surface temperature of enclosed hot components reduces to below the assigned maximum surface temperature of the electrical equipment

shall be marked with one of the following warning markings:

- an enclosure opening delay marking as specified in item a) of 29.12; or
- an enclosure opening marking as specified in item b) of 29.12.

6.4 Circulating currents in enclosures (e.g. of large electrical machines)

Where necessary, precautions shall be taken to guard against any effect due to the presence of circulating currents caused by stray magnetic fields, and the arcs or sparks that may occur as a result of interrupting such currents, or excessive temperatures caused by such currents.

NOTE 1 Stray magnetic fields can result in significant currents flowing both within and between bolted sections of multi-section enclosures often employed for large rotating electrical machines. This is most likely to occur during the starting of motors. It is important to avoid sparking from intermittent interruption of these currents.

NOTE 2 Although primarily a concern with large rotating machines, the same situation can occur in other equipment with large stray magnetic fields interacting with bolted sections of multi-section enclosures.

NOTE 3 Examples of precautions that can be taken include:

- the provision of equipotential bonding; or
- the provision of an adequate quantity of fasteners.

Where equipotential bonding conductors are employed, they shall be adequately rated for the anticipated currents and they shall be arranged to ensure reliable current transfer without the risk of sparking under adverse operating conditions, such as vibration or corrosion. The bonds shall be protected against corrosion and loosening in accordance with 15.4 and 15.5. Particular care shall be taken with bare flexible conductors in close proximity to the bonded parts.

Bonding conductors are not required where insulation ensures that circulating currents cannot flow between parts. The insulation of such parts shall be capable of withstanding a voltage of 100 V r.m.s for 1 min. However, provision shall be made for adequate earthing of isolated exposed conductive parts.

6.5 Gasket retention

Where the degree of protection provided by the enclosure depends on a gasketed joint which is intended to be opened for installation or maintenance purposes, gaskets shall be attached or secured to one of the mating faces to prevent loss, damage or incorrect assembly. The gasket material shall not itself adhere to the other joint face. When the joint is opened and re-closed prior to the tests for degree of protection by enclosure, it shall be verified that the gasket material has not adhered to the other joint face. (See 26.4.1.2).

NOTE An adhesive may be used for attaching a gasket to one of the mating faces.

6.6 Electromagnetic and ultrasonic energy radiating equipment

The energy levels shall not exceed the values given below.

NOTE Additional information on the application of higher power radiating sources can be found, for Group I and Group II, in CLC/TR50427. The results of the TR are based on far field conditions.

6.6.1 Radio frequency sources

The threshold power of radio frequency (9 kHz to 60 GHz) for continuous transmissions and for pulsed transmissions whose pulse durations exceed the thermal initiation time shall not exceed the values shown in Table 4. Programmable or software control intended for setting by the user shall not be permitted.

Table 4 – Radio frequency power thresholds

Equipment for	Threshold power W	Thermal initiation time
		μs
Group I	6	200
Group IIA	6	100
Group IIB	3,5	80
Group IIC	2	20
Group III	6	200

For pulsed radar and other transmissions where the pulses are short compared with the thermal initiation time, the threshold energy values Z_{th} shall not exceed those given in Table 5.

Table 5 – Radio-frequency energy thresholds

Equipment for	Threshold energy Z_{th}
	μJ
Group I	1 500
Group IIA	950
Group IIB	250
Group IIC	50
Group III	1 500

NOTE 1 In Tables 4 and 5, the same values are applied for Ma, Mb, Ga, Gb, Gc, Da, Db, or Dc equipment due to the large safety factors involved.

NOTE 2 In Tables 4 and 5, the values for Group III are adopted from Group I and not based on experimental results.

NOTE 3 In Tables 4 and 5; the values apply in normal operation, provided that the user of the equipment does not have access to adjust the equipment to give higher values. It is not necessary to consider possible increases in power caused by faults, due to the large safety margins involved and the strong likelihood that RF amplifiers will rapidly fail if a fault occurs that significantly increases the output power.

6.6.2 Lasers or other continuous wave sources

NOTE The values for Ga, Gb, and Gc can be found in IEC 60079-28.

The output parameters of lasers or other continuous wave sources of electrical equipment of EPL Ma or Mb shall not exceed the following values:

- 20 mW/mm² or 150 mW for continuous wave lasers and other continuous wave sources, and
- 0,1 mJ/mm² for pulse lasers or pulse light sources with pulse intervals of at least 5 s.

The output parameters of lasers or other continuous wave sources of electrical equipment of EPL Da or Db shall not exceed the following values:

- 5 mW/mm² or 35 mW for continuous wave lasers and other continuous wave sources, and
- 0,1 mJ/mm² for pulse lasers or pulse light sources with pulse intervals of at least 5 s.

The output parameters of lasers or other continuous wave sources of electrical equipment of EPL Dc shall not exceed the following:

- 10 mW/mm² or 35 mW for continuous wave lasers and other continuous wave sources, and

- 0,5 mJ/mm² for pulse lasers or pulse light sources.

Radiation sources with pulse intervals of less than 5 s are regarded as continuous wave sources.

6.6.3 Ultrasonic sources

The output parameters from ultrasonic sources of electrical equipment of EPL Ma, Mb, Ga, Gb, Gc, Da, Db, or Dc shall not exceed the following values:

- 0,1 W/cm² and 10 MHz for continuous sources,
- average power density 0,1 W/cm² and 2 mJ/cm² for pulse sources.

7 Non-metallic enclosures and non-metallic parts of enclosures

7.1 General

7.1.1 Applicability

The requirements given in this clause and in 26.7 shall apply to non-metallic enclosures and non-metallic parts of enclosures, on which the type of protection depends.

NOTE 1 Some examples of non-metallic parts of enclosures upon which the type of protection depends include cover sealing rings of an “e” or “t” enclosure, filling compounds of a “d” or “e” cable gland, sealing rings of cable glands, seals of switch actuators for an “e” enclosure, etc.

NOTE 2 Some of the subparts of this standard may make the “non-metallic parts of enclosures” requirements given in this clause applicable to parts, which are not enclosures, but on which the type of protection depends, e.g. “d” bushings, “e” terminals.

7.1.2 Specification of materials

7.1.2.1 General

The documents according to Clause 24 shall specify the material of the enclosure or part of the enclosure.

7.1.2.2 Plastic materials

The specification for plastic materials shall include the following:

- a) the name or registered trademark of the resin manufacturer or compounder;
- b) the identification of the material, including its
 - type designation,
 - colour,
 - type and percentage of fillers and other additives, if used;
- c) the possible surface treatments, such as varnishes, etc.;
- d) the temperature index TI, corresponding to the 20 000 h point on the thermal endurance graph without loss of flexural strength exceeding 50 %, determined in accordance with IEC 60216-1 and IEC 60216-2 and based on the flexing property in accordance with ISO 178. If the material does not break in this test before exposure to the heat, the index shall be based on the tensile strength in accordance with ISO 527-2 with test bars of Type 1A or 1B. As an alternative to the TI, the relative thermal index (RTI – mechanical) may be determined in accordance with ANSI/UL 746B.
- e) when applicable, data supporting compliance with 7.3 (resistance to ultraviolet light).

The source of the test data for these characteristics shall be identified.

NOTE It is not a requirement of this standard that conformity to the specification of the plastic material be verified.

7.1.2.3 Elastomers

The specification for elastomers shall include the following:

- a) the name or registered trademark of the resin manufacturer or compounder;
- b) the identification of the material, including its
 - type designation,
 - colour,
 - type and percentage of fillers and other additives, if used;
- c) the possible surface treatments, such as varnishes, etc.;
- d) the continuous operating temperature (COT);
- e) when applicable, data supporting compliance with 7.3 (resistance to ultraviolet light).

The source of the test data for these characteristics shall be identified.

NOTE It is not a requirement of this standard that conformity to the manufacturer's specification of the elastomer be verified.

7.2 Thermal endurance

7.2.1 Tests for thermal endurance

The tests for endurance to heat and to cold shall be conducted in accordance with 26.8 and 26.9.

7.2.2 Material selection

The plastic materials shall have a temperature index "TI" or RTI – mechanical (according to 7.1.2) of at least 20 K greater than the maximum service temperature of the enclosure or the part of the enclosure (see 26.5.1).

The elastomers shall have a continuous operating temperature (COT) range that includes a minimum temperature that is below, or equal to, the minimum service temperature and a maximum temperature that is at least 20 K above the maximum service temperature.

NOTE Equipment may have different service temperatures on different parts of the equipment. Selection and testing of individual materials is based on the specific service temperature of that part, but may alternatively be based on the maximum (or minimum) service temperature of the complete equipment.

7.2.3 Alternative qualification of elastomeric sealing O-rings

Elastomeric sealing O-rings are normally qualified as a part of the complete equipment enclosure when the ingress protection of the enclosure (IP) is required by the type of protection. Alternatively, a metal enclosure incorporating elastomeric sealing O-rings, according to ISO 3601-1, used in defined mounting conditions according to ISO 3601-2, is permitted to be evaluated using a test fixture instead of testing the O-ring assembled in the complete equipment enclosure. The test fixture shall replicate the dimensions of the complete equipment enclosure O-ring mounting. The tests shall be conducted according 26.16. The O-ring is then mounted in the complete equipment enclosure and subjected to the required IP tests of 26.4.5.

NOTE The compression set value determined after the tests of 26.16 is necessary for subsequent comparison to O-rings of alternative materials for the same application.

For the qualification of additional O-ring materials, the IP tests are not required if, subsequent to the tests of 26.16, the compression set of the alternative O-ring is less than or equal to that of the originally tested O-ring.

7.3 Resistance to light

The resistance to light of the enclosures, or parts of enclosures, of non-metallic materials shall be satisfactory (see 26.10). Materials meeting the ultraviolet light exposure requirements (f1) in ANSI/UL 746C are considered satisfactory.

Where not otherwise protected from exposure to light, a test of resistance of the material to ultraviolet light shall be made if the enclosure or parts of the enclosure, upon which the type of protection depends, are made of non-metallic materials. For Group I equipment, the test applies only to luminaires.

If the equipment is protected from light (for example, daylight or light from luminaires) when installed, and, in consequence, the test is not carried out, the equipment shall be marked by the symbol "X" to indicate this specific condition of use according to item 5.29.3.

NOTE 1 It is generally acknowledged that glass and ceramic materials are not adversely affected by the resistance to light test, and testing may not be necessary.

NOTE 2 The tests for resistance to light are conducted on special test bars and not on the enclosure. Therefore, the special test bars are not required to be subjected to the tests of enclosures (26.4) prior to the tests for resistance to light.

7.4 Electrostatic charges on external non-metallic materials

7.4.1 Applicability

The requirements of this subclause only apply to external non-metallic materials of electrical equipment.

The requirements of 7.4 also apply to non-metallic parts which are applied to the external surface of an enclosure.

NOTE 1 Non-metallic paints, films, foils, and plates are typically attached to external surfaces of enclosures to provide additional environmental protection. Their ability to store an electrostatic charge is addressed by this clause.

NOTE 2 It is generally acknowledged that glass is not susceptible to storing an electrostatic charge.

7.4.2 Avoidance of a build-up of electrostatic charge on Group I or Group II electrical equipment

Electrical equipment shall be so designed that under normal conditions of use, maintenance and cleaning, danger of ignition due to electrostatic charges shall be avoided. This requirement shall be satisfied by one of the following:

- a) by suitable selection of the material so that surface resistance complies with either of the limits given below when measured in accordance with 26.13;

$10^9 \Omega$ measured at (50 ± 5) % relative humidity; or

$10^{11} \Omega$ measured at (30 ± 5) % relative humidity

- b) by limitation of the surface area of non-metallic parts of enclosures as shown in Table 6.

The surface area is defined as follows:

- for sheet materials, the area shall be the exposed (chargeable) area;
- for curved objects, the area shall be the projection of the object giving the maximum area;
- for individual non-metallic parts, the area shall be evaluated independently if they are separated by conductive earthed frames.

The values for surface area can be increased by a factor of four if the exposed area of non-metallic material is surrounded by and in contact with conductive earthed frames.

Alternatively, for long parts with non-metallic surfaces, such as tubes, bars, or ropes, the surface area need not be considered, but the diameters or widths shall not exceed the values shown in Table 7. Cables for connection of external circuits are not considered to fall under this requirement. See 16.7.

- c) by limitation of a non-metallic layer bonded to a conductive surface. The thickness of the non-metallic layer shall not exceed the values shown in Table 8 or the breakdown voltage

shall be ≤ 4 kV (measured across the thickness of the insulating material according to the method described in IEC 60243-1);

- d) by provision of a conductive coating. Non-metallic surfaces may be covered with a bonded durable conductive coating. The resistance between coating and either the point of bond (in the case of equipment for fixed installations) or the farthest point of potential contact with the enclosure (in the case of portable equipment) shall not exceed $10^9 \Omega$. The resistance shall be measured in accordance with 26.13 but using a 100 mm^2 electrode at the worst case position of the surface and either the bond or the farthest point of potential contact. The equipment shall be marked "X" in accordance with item e) of 29.3 and the documentation shall provide guidance on the use of the bonding connection (for fixed equipment) and provide information to enable the user to decide on the durability of the coating material with respect to the environmental conditions;

NOTE 1 The environmental conditions that have an effect on the coating material may include influences from small particles in an air stream, solvent vapour, and the like.

- e) for fixed installations where the installation is intended to minimize the risk from electrostatic discharge, marking the equipment "X" in accordance with item e) of 29.3. . The instructions shall provide guidance for the user to minimize the risk from electrostatic discharge. Where practicable, the equipment shall also be marked with the electrostatic charge warning given in item g) of 29.12.

NOTE 2 Guidance on the risk of ignition from electrostatic discharge can be found in EN TR50404 and future IEC/TS 60079-32.

NOTE 3 Care should be taken when selecting the use of a warning label for static risk control. In many industrial applications, especially coal mining, it is highly likely that warning labels may become illegible through the deposition of dusts. If this is the case, it is possible that the act of cleaning the label may cause a static discharge.

NOTE 4 When selecting electrical insulating materials, attention should be paid to maintaining a minimum insulation resistance to avoid problems arising from touching exposed non-metallic parts that are in contact with live parts.

Table 6 – Limitation of surface areas

Maximum surface area mm ²				
Group I equipment	Group II equipment			
	Equipment protection level	Group IIA	Group IIB	Group IIC
10 000	EPL Ga	5 000	2 500	400
	EPL Gb	10 000	10 000	2 000
	EPL Gc	10 000	10 000	2 000

Table 7 – Maximum diameter or width

Maximum diameter or width mm				
Group I equipment	Group II equipment			
	Equipment protection level	Group IIA	Group IIB	Group IIC
30	EPL Ga	3	3	1
	EPL Gb	30	30	20
	EPL Gc	30	30	20

Table 8 – Limitation of thickness of non-metallic layer

Maximum thickness mm				
Group I equipment	Group II equipment			
	Equipment protection level	Group IIA	Group IIB	Group IIC
2	EPL Ga	2	2	0,2
	EPL Gb	2	2	0,2
	EPL Gc	2	2	0,2

NOTE 5 These thickness limitations do not apply to non-metallic layers that have a surface resistance of less than $10^9 \Omega$ or $10^{11} \Omega$, as applicable. See 7.4.2 a).

NOTE 6 One of main reasons for the thickness limitation is that the maximum thickness of non-metallic layer is intended to permit dissipation of charge through the insulation to earth, By this means the static charge is not able to build up to incendive levels.

7.4.3 Avoidance of a build-up of electrostatic charge on equipment for Group III

Painted/coated metal equipment and equipment of plastic material shall be so designed that under normal conditions of use, danger of ignition due to propagating brush discharges is avoided.

Enclosures of plastic material cannot be charged to such a critical charge density that propagating brush discharges can be generated. However, no extended flat conductive surfaces shall be installed inside the enclosure within a distance of 8 mm to the outer surface.

NOTE 1 An internal printed circuit board may be considered to be an extended flat conductive surface, though this need not be applied in small hand-held equipment unless the equipment is likely to be subjected to a prolific charge generating mechanism (such as might occur in pneumatic transfer of powders or charge spraying in a powder coating process). Charging through normal handling of hand-held equipment is not considered to lead to a prolific charge generating mechanism and therefore would not lead to a situation where a propagating brush discharge might occur.

NOTE 2 A single flat conductive surface not exceeding 500 mm^2 is not considered to be an extended flat surface. This allows for the standoffs or brackets used for the mounting of conductive flat plates inside of an enclosure.

If plastic with a surface area exceeding 500 mm^2 is employed as a covering on a conductive material, the plastic shall have one or more of the following characteristics:

- by suitable selection of the material so that surface resistance complies with the limits given in 26.13;
- a breakdown voltage $\leq 4 \text{ kV}$ (measured across the thickness of the insulating material according to the method described in IEC 60243-1);
- a thickness $\geq 8 \text{ mm}$ of the external insulation on metal parts;

NOTE 3 External insulation of 8 mm and greater on metal parts such as measurement probes or similar components make propagating brush discharges unlikely to occur. When evaluating the minimum thickness of the insulation to be used or specified it is necessary to allow for any expected wear under normal usage.

- by marking the equipment "X" in accordance with item e) of 29.3. This is only applicable to electrical equipment intended for fixed installations where the installation is intended to minimize the risk from electrostatic discharge. The instructions shall provide guidance for the user to minimize the risk from electrostatic discharge.

7.5 Accessible metal parts

Accessible, metal parts with a resistance to earth of more than $10^9 \Omega$ could be susceptible to electrostatic charges that could become a source of ignition and shall be tested in accordance with the test method in 26.14. If the measured capacitance of each metal part exceeds the value shown in Table 9, the equipment shall be marked "X" in accordance with item e) of 29.3

and the specific condition of use shall specify the value of capacitance determined to allow the user to determine suitability in the specific application.

NOTE 1 Guidance on the risk of ignition from electrostatic discharge can be found in EN TR50404 and IEC/TR60079-32 (in preparation).

Table 9 – Maximum capacitance of unearthed metal parts

Maximum capacitance pF				
Group I or Group III equipment	Group II equipment			
	Equipment protection level	Group IIA	Group IIB	Group IIC
10	EPL Ma	3	3	3
	EPL Mb	10	10	3
	EPL Gc	10	10	3

NOTE 2 It is generally accepted that an unearthed metal fastener such as a cover screw will present a capacitance of not more than 3 pF.

NOTE 3 For Group III equipment intended for use in ducts or pipes subject to the presence of fast moving dust, a lower limiting value for capacitance is under consideration.

8 Metallic enclosures and metallic parts of enclosures

8.1 Material composition

The documents according to Clause 24 shall specify the material of the enclosure or part of the enclosure.

NOTE 1 It is not a requirement of this standard that the chemical composition of material be verified by test.

NOTE 2 Paint or coatings applied to metallic enclosures may also have to be considered as non-metallic parts of an enclosure and the requirements of Clause 7 apply.

8.2 Group I

Materials used in the construction of enclosures of Group I electrical equipment of EPL Ma or Mb shall not contain, by mass, more than

- 15 % in total of aluminium, magnesium, titanium and zirconium, and
- 7,5 % in total of magnesium, titanium and zirconium.

The above requirement need not apply to Group I portable measuring equipment, but this equipment shall then be marked "X" in accordance with item e) of 29.3 and the specific condition of use shall indicate the special precautions to be applied during storage, transportation and use.

8.3 Group II

Materials used in the construction of enclosures of Group II electrical equipment for the identified equipment protection levels shall not contain, by mass, more than:

- for EPL Ga
10 % in total of aluminium, magnesium, titanium and zirconium, and
7,5 % in total of magnesium, titanium and zirconium;
- for EPL Gb
7,5 % in total of magnesium, titanium and zirconium;

- for EPL Gc
no requirements except for fan impellers, fan hoods and ventilating screens, which shall comply with the requirements for EPL Gb.

When the material limits are exceeded for equipment of EPL Ga or Gb, the equipment shall be marked with an "X" in accordance with item e) of 29.3 and the specific conditions of use shall contain sufficient information to enable the user to determine the suitability of the equipment for the particular application, for example, to avoid an ignition hazard due to impact or friction.

8.4 Group III

Materials used in the construction of enclosures of Group III electrical equipment for the identified equipment protection levels shall contain, by mass, more than:

- for EPL Da
7,5 % in total of magnesium, titanium and zirconium;
- for EPL Db
7,5 % in total of magnesium, titanium and zirconium;
- for EPL Dc
no requirements except for fan impellers, fan hoods and ventilating screens, which shall comply with the requirements for EPL Db.

When the material limits are exceeded for equipment of EPL Da or Db, the equipment shall be marked with an "X" in accordance with item e) of 29.3 and the specific conditions of use shall contain sufficient information to enable the user to determine the suitability of the equipment for the particular application, for example, to avoid an ignition hazard due to impact or friction.

9 Fasteners

9.1 General

Parts necessary to achieve a specific type of protection or used to prevent access to uninsulated live parts shall be capable of being released or removed only with the aid of a tool.

Fastening screws for enclosures of materials containing light metals may be made of light metal or non-metallic material if the material of the fastener is compatible with that of the enclosure.

Threaded holes for fasteners which secure covers intended to be opened in service for adjustment, inspection and other operational reasons shall only be tapped into the material when the thread form is compatible with the material of the enclosure.

9.2 Special fasteners

When any of the standards for a specific type of protection requires a special fastener, this shall conform to the following:

- the thread shall be a metric thread of coarse pitch in accordance with ISO 262, with a tolerance fit of 6g/6H in accordance with ISO 965-1 and ISO 965-3;
- the head of the screw or nut shall be in accordance with ISO 4014, ISO 4017, ISO 4032, ISO 4762, ISO 7380, or ISO 14583 and, in the case of hexagon socket set screws, ISO 4026, ISO 4027, ISO 4028 or ISO 4029; Other heads of a screw or nut are permitted if the equipment is marked "X" in accordance with item e) of 29.3 and the specific condition of use shall fully specify the fasteners and indicate that the fasteners shall only be replaced with identical ones;
- the holes in the electrical equipment shall comply with the requirements of 9.3.

NOTE For Group I electrical equipment, the heads of special fasteners liable to mechanical damage in normal service, which may invalidate the type of protection, should be protected, for example, by the use of shrouds or counter-bored holes.

9.3 Holes for special fasteners

9.3.1 Thread engagement

Holes for special fasteners, as specified in 9.2, shall be threaded for a distance to accept a thread engagement, h , at least equal to the major diameter of the thread of the fastener (see Figures 1 and 2).

9.3.2 Tolerance and clearance

The female thread shall have a tolerance class of 6H in accordance with ISO 965-1 and ISO 965-3, and either

- the hole under the head of the associated fastener shall allow a clearance not greater than that specified for the “medium series: H13” per ISO 273 (see Figure 1); or
- the hole under the head (or nut) of an associated reduced shank fastener shall be threaded to enable the fastener to be retained. The dimensions of the threaded hole shall be such that the surrounding surface in contact with the head of such a fastener shall be at least equal to that of a fastener without a reduced shank in a clearance hole (see Figure 2).

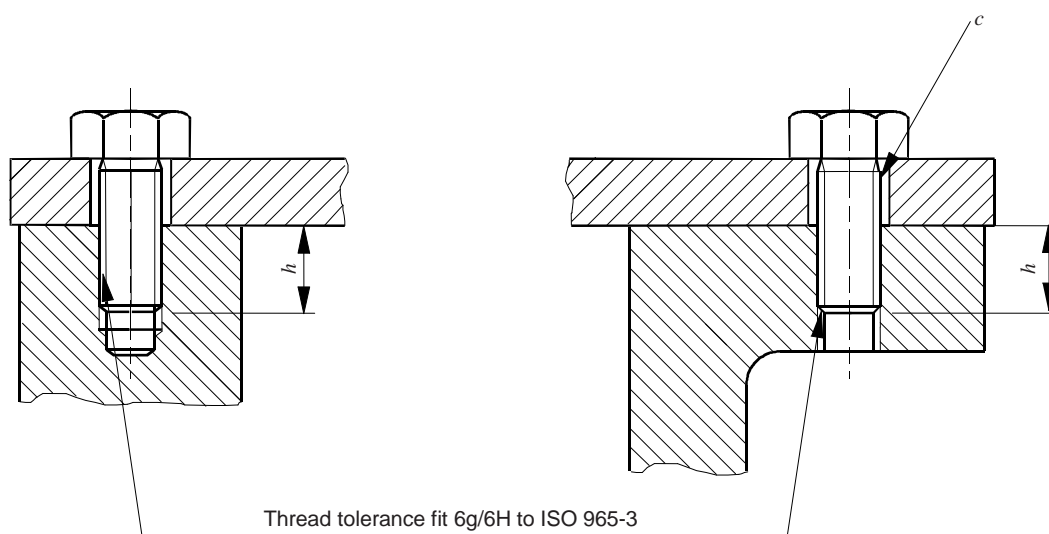

IEC 1969/07

Key

h ≥ major diameter of the thread of the fastener

c ≤ maximum clearance permitted for the “medium series: H13” per ISO 273

Figure 1 – Tolerances and clearance for threaded fasteners

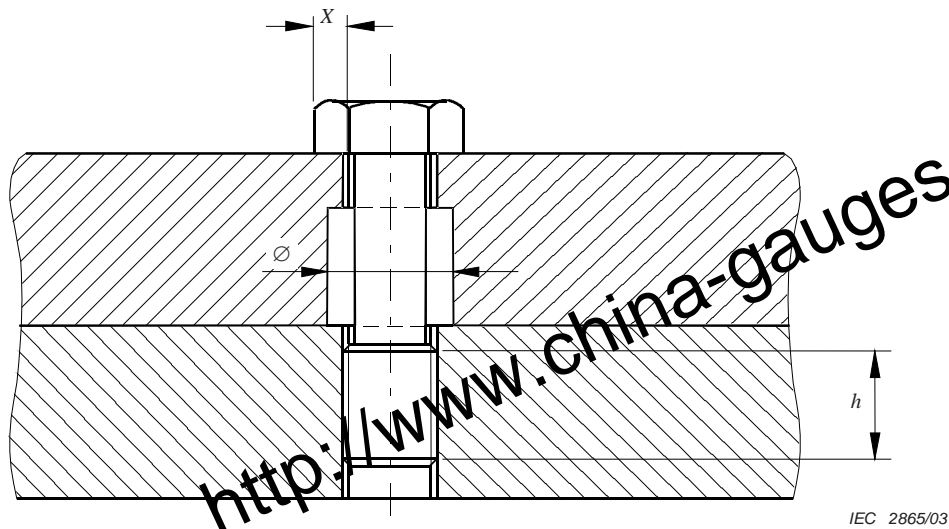

Key

- Ø standard clearance hole appropriate to the thread form
- h \geq major diameter of the thread of the fastener
- X contact dimension of a reduced shank fastener
- X \geq the contact dimension of a standard head of a standard fastener (without reduced shank) threaded throughout its length with the size of thread used

Figure 2 – Contact surface under head of fastener with a reduced shank

9.3.3 Hexagon socket set screws

Ⓒ11 In the case of threaded holes for hexagon socket set screws, the threaded hole shall have a tolerance class of 6H in accordance with ISO 965-1 and ISO 965-3 and the set screw shall not protrude from the threaded hole after tightening. Ⓒ11

10 Interlocking devices

Where an interlocking device is used to maintain a specific type of protection, it shall be so constructed that its effectiveness cannot easily be defeated.

NOTE The intent is that the interlock be designed such that it cannot be easily defeated by common tools such as a screwdriver, pliers, or a similar tool.

11 Bushings

Bushings used as connection facilities and which may be subjected to a torque during connection or disconnection, shall be mounted in such a way that all parts are secured against turning.

The relevant torque test is specified in 26.6.

12 Materials used for cementing

The documents, according to Clause 24, shall include a data sheet or statement from the cement manufacturer to show that, the materials used for cementing on which the type of protection depends, have a thermal stability adequate for the minimum and maximum service temperatures to which they shall be subjected.

The materials used for cementing shall have a continuous operating temperature (COT) range that includes a minimum temperature that is below, or equal to, the minimum service temperature and a maximum temperature that is at least 20 K above the maximum service temperature.

NOTE 1 Equipment may have different service temperatures on different parts of the equipment. Selection and testing of individual materials is based on the specific service temperature of that part, but may alternatively be based on the maximum (or minimum) service temperature of the complete equipment.

NOTE 2 If the cementing is to withstand adverse service conditions, appropriate measures should be agreed between the user and the manufacturer (see 6.1).

13 Ex Components

13.1 General

Ex Components shall comply with the requirements given in Annex B. Examples of Ex Components include:

- a) an empty enclosure; or
- b) components or assemblies of components for use with equipment which complies with the requirements of one or more of the types of protection listed in Clause 1.

13.2 Mounting

Ex Components may be mounted:

- a) completely within an equipment enclosure (for example, a type "e" terminal, ammeter, heater or indicator; a type "d" switch component or thermostat, a type "m" switch component or thermostat, a type "i" supply); or
- b) completely external to the equipment enclosure (for example, a type "e" earth terminal, a type "i" sensor); or
- c) partly within and partly external to the equipment enclosure (for example, a type "d" push button switch, a type "t" push button switch, a limit switch or indicating lamp, a type "e" ammeter, a type "i" indicator).

13.3 Internal mounting

Where the Ex Component is mounted completely within the enclosure, the only parts that shall be tested or assessed are those parts which have not been tested and/or assessed as a separate component (for example, test or assessment of surface temperature, creepage distance and clearance from the component to surrounding conducting parts).

13.4 External mounting

Where the Ex Component is mounted external to the enclosure or partly within and partly external to the enclosure, the interface between the Ex Component and the enclosure shall be tested or assessed for compliance with the relevant type of protection and the enclosure tests as specified in 26.4.

13.5 Ex Component certificate

As Ex Components are not intended to be used alone and require additional consideration when incorporated into electrical equipment or systems, they do not have "Specific Conditions of Use" along with the associated "X" suffix for the certificate number. Where this standard or one of its sub-parts specify "Specific Conditions of Use" and the associated "X" suffix for the certificate number, a "Schedule of Limitations" for the Ex Component certificate and the associated "U" suffix for the Ex Component certificate number shall be substituted for an Ex Component. See also 28.2.

14 Connection facilities and termination compartments

14.1 General

Electrical equipment intended for connection to external circuits shall include connection facilities, with the exception of electrical equipment that is manufactured with a cable permanently connected to it.

14.2 Termination compartment

Termination compartments and their access openings shall be dimensioned so that the conductors can be readily connected.

14.3 Type of protection

Termination compartments shall comply with one of the specific types of protection listed in Clause 1.

14.4 Creepage and clearance

Termination compartments shall be so designed that after proper connection of the conductors, the creepage distances and the clearances comply with the requirements, if any, of the specific type of protection concerned.

15 Connection facilities for earthing or bonding conductors

15.1 Equipment requiring earthing

15.1.1 Internal

A connection facility for the connection of an earthing conductor shall be provided inside the electrical equipment adjacent to the other connection facilities.

15.1.2 External

An additional external connection facility for an equipotential bonding conductor shall be provided for electrical equipment with a metallic enclosure, except for electrical equipment which is designed to be:

- a) moved when energized and is supplied by a cable incorporating an earthing or equipotential bonding conductor; or
- b) installed only with wiring systems not requiring an external earth connection, for example, metallic conduit or armoured cable.

The manufacturer shall provide details on any earthing or equipotential bonding required for the installation under conditions a) or b) above in the instructions provided in accordance with Clause 30.

The additional external connection facility shall be electrically in contact with the connection facility required in 15.1.1.

NOTE The expression "electrically in contact" does not necessarily involve the use of a conductor.

15.2 Equipment not requiring earthing

Where there is no requirement for earthing or bonding, for example, in some types of electrical equipment having double or reinforced insulation, or for which supplementary earthing is not necessary, an internal or external earthing or bonding facility need not be provided.

NOTE Double insulated equipment, while not presenting a risk of electrical shock, may need to be earthed or bonded to reduce the risk of ignition.

15.3 Size of conductor connection

Protective earthing (PE) conductor connection facilities shall allow for the effective connection of at least one conductor with a cross-sectional area given in Table 10. Protective earthing (PE) conductor connection facilities for electrical machines shall be according to IEC 60034-1.

Table 10 – Minimum cross-sectional area of PE conductors

Cross-sectional area of phase conductors, S mm ²	Minimum cross-sectional area of the corresponding PE conductor, S_p mm ²
$S \leq 16$	S
$16 < S \leq 35$	16
$S > 35$	$0,5 S$

Equipotential bonding connection facilities on the outside of electrical equipment shall provide effective connection of a conductor with a cross-sectional area of at least 4 mm². When this connection facility is also intended to serve as the PE connection, the requirements of Table 10 apply.

15.4 Protection against corrosion

Connection facilities shall be effectively protected against corrosion. Special precautions shall be taken if one of the parts in contact consists of a material containing light metal, for example, by using an intermediate part made of steel when making a connection to a material containing light metals.

15.5 Secureness of electrical connections

Connection facilities shall be designed so that the electrical conductors cannot be readily loosened or twisted. Contact pressure on the electrical connections shall be maintained and not be affected by dimensional changes of insulating materials in service, due to factors such as temperature or humidity. For non-metallic walled enclosures provided with an internal earth continuity plate, the test of 26.12 shall be applied.

NOTE An internal earth continuity plate may be fitted, for example, to allow for use of metallic cable glands without the use of separate individual earthing tags. The material and dimensions of the earth continuity plate should be appropriate for the anticipated fault current.

16 Entries into enclosures

16.1 General

Entry into the equipment shall be either by a plain or threaded hole located in

- the wall of the enclosure, or
- an adaptor plate designed to be fitted in or on the walls of the enclosure.

NOTE Further information on the installation of conduit or associated fittings into threaded or plain holes can be found in IEC 60079-14.

16.2 Identification of entries

The manufacturer shall specify, in the documents submitted according to Clause 24, the entries, their position on the equipment and the number permitted. The thread form (for

example, metric or NPT) of threaded entries shall be marked on the equipment or shall appear in the installation instructions (see Clause 30).

NOTE 1 It is not intended that individual entries be marked, unless required by the specific type of protection.

NOTE 2 Where a great variety of possible locations for entries is foreseen, the area for the entries, the size of entries and entry spacing are typically provided.

16.3 Cable glands

Cable glands, when installed in accordance with the instructions required by Clause 30, shall not invalidate the specific characteristics of the type of protection of the electrical equipment on which they are mounted. This shall apply to the whole range of cable dimensions specified by the manufacturer of the cable glands as suitable for use with those glands. Cable glands may form an integral part of the equipment, i.e. one major element or part forms an inseparable part of the enclosure of the equipment. In such cases, the glands shall be tested with the equipment.

Non-threaded cable glands shall be certified as Ex Components or certified with the complete equipment.

Threaded cable glands and cable transit devices shall be certified as Ex Cable Glands, certified as Ex Components, or certified with the complete equipment.

Cable glands, whether integral or separate, shall meet the relevant requirements of Annex A.

16.4 Blanking elements

Blanking elements, intended to close unused openings in the enclosure walls of electrical equipment, shall satisfy the requirements of the specific type of protection concerned. The blanking element shall only be removable with the aid of a tool.

Non-threaded blanking elements shall be certified as Ex Components or certified with the complete equipment.

Threaded blanking elements shall be certified as Ex Blanking Elements, certified as Ex Components, or certified with the complete equipment.

16.5 Thread adapters

Thread adapters shall satisfy the requirements of the specific type of protection concerned.

Thread adapters shall be certified as Ex Thread Adapters, certified as Ex Components, or certified with the complete equipment.

16.6 Temperature at branching point and entry point

When the temperature under rated conditions is higher than 70 °C at the entry point or 80 °C at the branching point of the conductors, information shall be marked on the equipment exterior to provide guidance to the user on the proper selection of cable and cable gland or conductors in conduit. See Figure 3.

NOTE In cases where the information for the proper selection of cables, cable glands, and conductors in conduit is extensive, the marking need only be a reference to detailed information in the equipment instructions.

16.7 Electrostatic charges of cable sheaths

For the purposes of this standard, the sheaths of cables used for the connection of external circuits are not considered non-metallic enclosures or parts of enclosures as described by Clause 7 and need not be assessed against those requirements.

NOTE The electrostatic risk of cables is addressed by IEC 60079-14.

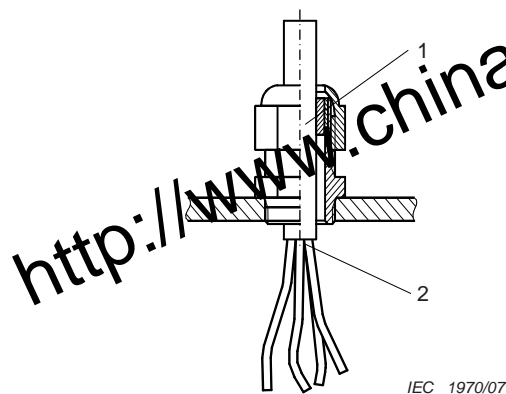

Figure 3a – Cable gland

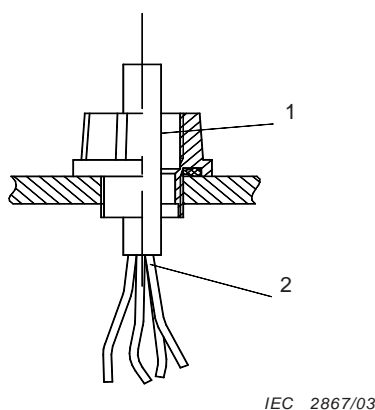

Figure 3b – Conduit entry

Key

- 1 entry point (where the sealing, if any, occurs)
- 2 branching point

Figure 3 – Illustration of entry points and branching points

17 Supplementary requirements for rotating machines

17.1 Ventilation

17.1.1 Ventilation openings

The degree of protection (IP) of ventilation openings shall be at least:

- IP20 on the air inlet side,
- IP10 on the air outlet side,

according to IEC 60034-5.

For vertical rotating machines and vertical rotating fans, foreign objects shall be prevented from falling into the ventilation openings. For Group I rotating machines, the degree of

protection IP10 is adequate only when the openings are designed or arranged so that foreign objects with dimensions above 12,5 mm cannot be carried onto the moving parts of the machine either by falling vertically or by vibration.

For fans intended to be mounted in ventilation duct systems, the requirements for IP-protection and other requirements for parts providing the IP-protection (e.g. impact test, light alloy requirements) can be fulfilled at the inlet and outlet of the duct. In such a case, the fan shall be marked "X" in accordance with item e) of 29.3 and the specific condition of use shall specify the criteria for the selection of the inlet and outlet guarding.

17.1.2 Materials for external fans

The external fan impellers, fan hoods, and ventilation screens manufactured from non-metallic materials shall comply with Clause 7. For Group II rotating machines, impellers of external fans having a peripheral speed of below 50 m/s, need not comply with the requirements of 7.4.

The external fan impellers, fan hoods, and ventilation screens manufactured from materials containing light metals, shall comply with Clause 8.

17.1.3 Cooling fans of rotating machines

17.1.3.1 Fans and fan hoods

External cooling fans of rotating machines shall be enclosed by a fan hood and shall meet the requirements of 17.1.3.2 and 17.1.3.3.

17.1.3.2 Construction and mounting of the ventilating systems

Fans, fan hoods and ventilation screens shall be constructed to meet the requirements of the resistance to impact test according to 26.4.2 and the acceptance criteria given in 26.4.4.

17.1.3.3 Clearances for the ventilating system

Taking into account design tolerances, the clearances in normal operation between the fan impellor and its fan hood, the ventilation screens and their fasteners, shall be at least one-hundredth of the maximum diameter of the fan impellor, except that the clearances need not exceed 5 mm and may be reduced to 1 mm where the opposing parts are manufactured so as to have controlled dimensional concentricity and dimensional stability (e.g. machined parts of cast metal). In no case shall the clearance be less than 1 mm.

17.1.4 Auxiliary motor cooling fans

Cooling fans that are not mounted on the shaft of the motor to be cooled, and which require a minimum back-pressure in order to not exceed the rating of the fan motor, shall either be tested as part of the motor to be cooled or shall be marked "X" in accordance with item e) of 29.3 and the specific condition of use shall specify the measures to be considered to not exceed the ratings. If limits for back-pressure are specified as such conditions, these limits shall be verified by testing according to 26.15.

17.1.5 Ventilating fans

☐ For Group I equipment, the applicable requirements of EN 1710 shall be applied.

For Group II and Group III equipment, all requirements except marking of EN 14986 shall be applied. ☐

17.2 Bearings

Lubricants and seals used in bearings shall be suitable for the maximum temperature of the bearings.

Additional requirements are under consideration.

NOTE Shaft and bearing currents may be a primary source of ignition, and may also considerably influence the lifetime of the bearings. Practice has shown that the lifetime can be only few weeks and thus practically impossible to predict by traditional conditioning monitoring methods. Thus, the possibility of shaft currents in the system should be analyzed and, if needed, the whole system should be designed accordingly to reduce the likelihood of unexpected bearing damage. See Annex D for additional guidance.

18 Supplementary requirements for switchgear

18.1 Flammable dielectric

Switchgear shall not have contacts immersed in flammable dielectric.

18.2 Disconnectors

Where switchgear includes a disconnector, it shall disconnect all poles. The switchgear shall be designed so that either

- the position of the disconnector contacts is visible, or
- their open position is reliably indicated (see IEC 60947-1).

If an interlock is not provided between the disconnector and the cover or door of the switchgear to ensure that the cover or door can only be opened when the disconnector contacts are open, a warning according to item d) of 29.12 shall be marked on the equipment.

Disconnectors, which are not designed to be operated under the intended load, shall either

- be electrically or mechanically interlocked with a suitable load breaking device, or
- for Group II equipment only, be marked at a place near the actuator of the disconnector, with the operation under load marking given in item c) of 29.12.

18.3 Group I – Provisions for locking

For Group I switchgear, the operating mechanism of disconnectors shall be capable of being padlocked in the open position. Provision shall be made to enable short-circuit and earth-fault relays, if used, to latch out. If the switchgear has a local resetting device which is accessible from the outside of the enclosure, its access cover shall have a special fastener according to 9.2.

18.4 Doors and covers

Doors and covers giving access to the interior of enclosures containing remotely operated circuits with switching contacts which can be made or broken by non-manual influences (such as electrical, mechanical, magnetic, electromagnetic, electro-optical, pneumatic, hydraulic, acoustic or thermal) shall either

- a) be interlocked with a disconnector which prevents access to the interior, unless it has been operated to disconnect unprotected internal circuits; or
- b) be marked with the enclosure opening marking of item d) of 29.12.

In the case of a) above, where it is intended that some internal parts shall remain energized after operation of the disconnector, in order to minimize the risk of explosion, those energized parts shall be protected by either

- 1) one of the appropriate types of protection listed in Clause 1; or
- 2) protection as follows:
 - clearances and creepage distances between phases (poles) and to earth in accordance with the requirements of IEC 60079-7; and
 - internal supplementary enclosure(s) which contain(s) the energized parts and provide(s) a degree of protection of at least IP20, according to IEC 60529; and
 - marking on the internal supplementary enclosure as required by item h) of 29.12.

NOTE Equipment that can remain energized after the operation of the disconnector includes equipment supplied by cells and batteries internal to the equipment.

19 Supplementary requirements for fuses

Enclosures containing fuses shall either

- be interlocked so that insertion or removal of replaceable elements can be carried out only with the supply disconnected and so that the fuses cannot be energized until the enclosure is correctly closed, or
- the equipment shall be marked with the enclosure opening marking as required by item d) of 29.12.

20 Supplementary requirements for plugs, socket outlets and connectors

20.1 General

These requirements for socket outlets shall also be applied to connectors.

Plugs and socket outlets shall be either

- a) interlocked mechanically, or electrically, or otherwise designed so that they cannot be separated when the contacts are energized and the contacts cannot be energized when the plug and socket outlet are separated, or
- b) fixed together by means of special fasteners according to 9.2 and the equipment marked with the separation marking as required by item e) of 29.12.

Where they cannot be de-energized before separation because they are connected to a battery, the marking shall state the separation warning required by item f) of 29.12.

20.2 Explosive gas atmospheres

It is not necessary for plugs and socket outlets of EPL Gb to comply with the requirements of 20.1 if all of the following conditions are met:

- the part which remains energized is a socket outlet;
- there is a delay time for the separation of the plug and socket outlet such that the rated current flow ceases so no arc will occur on separation;
- the plug and socket outlet remain flameproof in accordance with IEC 60079-1 during the arc-quenching period while opening a circuit of the rated voltage, rated current, and for a.c. circuits, a power factor of 0,4 to 0,5;
- the contacts remaining energized after separation are protected according to one of the specific types of protection listed in Clause 1.

20.3 Explosive dust atmospheres

The requirements of 20.1 apply in all cases.

20.4 Energized plugs

Plugs and components remaining energized when not engaged with a socket outlet are not permitted.

21 Supplementary requirements for luminaires

21.1 General

The source of light of luminaires shall be protected by a light transmitting cover that may be provided with an additional guard. Dependent on the size of the openings in a guard, the tests according to 26.4.2, Table 13 are to be applied as follows:

- Guard openings greater than 2 500 mm²; tests a) and c) of Table 13.
- Guard openings between 625 mm² and 2 500 mm²; tests a), b) and d) of Table 13.
- Guard openings less than 625 mm²; tests a) and b) of Table 13.
- No guard; tests a) and c) of Table 13.

The mounting of luminaires shall not depend on just one screw. A single eyebolt may be used only if this is an integral part of the luminaire, for example by being cast or welded to the enclosure or, if threaded, the eyebolt is locked by a separate means against loosening when twisted.

21.2 Covers for luminaires of EPL Mb, EPL Gb, or EPL Db

Covers giving access to the lampholder and other internal parts of luminaires shall either be

- a) interlocked with a device which automatically disconnects all poles of the lampholder as soon as the cover opening procedure begins, or
- b) marked with the opening marking as required by item d) of 29.12.

In the case of a) above, where it is intended that some parts other than the lampholder will remain energized after operation of the disconnecting device, in order to minimize the risk of explosion, those energized parts shall be protected by either

- 1) one of the appropriate types of protection (for the required EPL) listed in Clause 1, or
- 2) the means of protection given below:
 - the disconnecting device shall be so arranged that it cannot be operated manually to inadvertently energize unprotected parts; and
 - clearances and creepage distances between phases (poles) and to earth in accordance with the requirements of IEC 60079-7; and
 - an internal supplementary enclosure, which can be the reflector for the light source, which contains the energized parts and provides a degree of protection of at least IP20, according to IEC 60529; and
 - marking on the internal supplementary enclosure as required by item h) of 29.12.

21.3 Covers for luminaires of EPL Gc or EPL Dc

Covers giving access to the lampholder and other internal parts of luminaires shall either be

- a) interlocked with a device which automatically disconnects all poles of the lampholder as soon as the cover opening procedure begins, or
- b) marked with the opening marking as required by item d) of 29.12.

In the case of a) above, where it is intended that some parts other than the lampholder will remain energized after operation of the disconnecting device, in order to minimize the risk of explosion, those energized parts shall be protected by

- clearances and creepage distances between phases (poles) and to earth in accordance with the requirements of IEC 60664-1 with over-voltage category II and pollution degree 3; and
- an internal supplementary enclosure, which can be the reflector for the light source, which contains the energized parts and provides a degree of protection of at least IP20, according to IEC 60529; and
- marking on the internal supplementary enclosure as required by item 29.12.

21.4 Sodium lamps

- Lamps containing free metallic sodium (for example, low-pressure sodium lamps in accordance with IEC 60192) are not permitted.
- High-pressure sodium lamps (for example, in accordance with IEC 60662) may be used.

NOTE The use of lamps containing free metallic sodium is not permitted because of the risk of ignition from a broken lamp (occurring for example during lamp replacement) if the free metallic sodium should come into contact with water.

22 Supplementary requirements for caplights and handlights

22.1 Group I caplights

NOTE The requirements for caplights for use in mines susceptible to firedamp are contained in IEC 62013-1 (to be replaced by IEC 60079-35-1 which is in preparation).

22.2 Group II and Group III caplights and handlights

Leakage of the electrolyte shall be prevented in all positions of the equipment.

Where the source of light and the source of supply are housed in separate enclosures, which are not mechanically connected other than by an electric cable; the cable glands and the connected cable shall be tested according to A.3.1 or A.3.2, as appropriate. The test shall be carried out using the cable which is to be used for connecting both parts. The type, dimensions and other relevant information about the cable which is to be used shall be specified in the manufacturer's documentation.

23 Equipment incorporating cells and batteries

23.1 General

The requirements in 23.2 to 23.12 shall apply for all cells and batteries incorporated into explosion-protected equipment.

23.2 Batteries

Batteries incorporated into explosion-protected equipment shall be formed only from cells connected in series.

23.3 Cell types

Only cell types referred to in published IEC cell standards having known characteristics shall be used. Tables 11 and 12 below list cells for which suitable standards either exist or are to be produced.

Table 11 – Primary cells

IEC 60086-1 type	Positive electrode	Electrolyte	Negative electrode	Nominal voltage (for surface temperature assessment) V	Maximum open-circuit voltage (for spark hazard assessment) V
-	Manganese dioxide (MnO ₂)	Ammonium chloride, zinc chloride	Zinc (Zn)	1,5	1,725
A	Oxygen (O ₂)	Ammonium chloride, zinc chloride	Zinc (Zn)	1,4	1,55
B	Carbon monofluoride (CF) _x	Organic electrolyte	Lithium (Li)	3	3,7
C	Manganese dioxide (MnO ₂)	Organic electrolyte	Lithium (Li)	3	3,7
E	Thionyl chloride (SOCl ₂)	Non-aqueous inorganic	Lithium (Li)	3,6	3,9
F	Iron disulfide (FeS ₂)	Organic electrolyte	Lithium (Li)	1,5	1,83
G	Copper (II) oxide (CuO)	Organic electrolyte	Lithium (Li)	1,5	2,3
L	Manganese dioxide (MnO ₂)	Alkali metal hydroxide	Zinc (Zn)	1,5	1,65
P	Oxygen (O ₂)	Alkali metal hydroxide	Zinc (Zn)	1,4	1,68
S	Silver oxide (Ag ₂ O)	Alkali metal hydroxide	Zinc (Zn)	1,55	1,63
^a	Sulphur dioxide SO ₂)	Non-aqueous organic salt	Lithium (Li)	3,0	3,0
^a	Mercury (Hg)	Alkali metal hydroxide	Zinc (Zn)	Data awaited	Data awaited

NOTE Zinc/manganese dioxide cells are listed in IEC 60086-1, but not classified by a type letter.

^a May only be used if an IEC cell standard exists.

Table 12 – Secondary cells

Relevant IEC standard type	Type	Electrolyte	Maximum charging voltage (per cell) V	Nominal voltage ¹ (for surface temperature assessment) V	Peak open circuit voltage (for spark hazard assessment) V
IEC 60896-11 IEC 60254 IEC 60095-1 IEC 60896-21 IEC 60952 IEC 61427 IEC 61056-1	Lead-acid for stationary use (flooded) Lead-acid motive for power application Lead-acid for starting and ignition Lead-acid for stationary use (VRLA) Lead-acid for aircraft use Lead-acid for photovoltaic energy storage Lead-acid for general purpose	Sulphuric acid (SG 1,25 to 1,32)	Up to 2,7	2,2	2,67 ^b 2,35 ^c
Type K IEC 61951-1 IEC 60623 IEC 60622	Nickel-cadmium ²	Potassium hydroxide (SG 1,3)	1,6	1,3	1,55
^a	Nickel-iron	Potassium hydroxide (SG1,3)	1,6	1,3	1,6
IEC 61960	Lithium	Non-aqueous organic salt	up to 4,2	3,8	4,2

Relevant IEC standard type	Type	Electrolyte	Maximum charging voltage (per cell) V	Nominal voltage ¹ (for surface temperature assessment) V	Peak open circuit voltage (for spark hazard assessment) V
IEC 61951-2	Nickel metal hydride ²	Potassium hydroxide	1,5	1,6	1,6
<p>a May only be used if an IEC cell standard exists.</p> <p>b wet cell – cell containing an liquid electrolyte that can be replenished</p> <p>c dry cell – cell containing an immobilized electrolyte</p> <p>1 Voltage figure includes appropriate factor. Temperature rise tests conducted at this voltage.</p> <p>2 Chemistry uses constant current technique to charge.</p>					

23.4 Cells in a battery

All cells in a battery shall be of the same electrochemical system, cell design and rated capacity and shall be made by the same manufacturer.

23.5 Ratings of batteries

All batteries shall be arranged and operated so as to be within the allowable limits defined by the cell or battery manufacturer.

23.6 Interchangeability

Primary and secondary cells or batteries shall not be used inside the same equipment enclosure if they are readily interchangeable.

23.7 Charging of primary batteries

Primary batteries shall not be re-charged. Where another voltage source exists inside equipment containing primary batteries and there is a possibility of interconnection, precautions shall be taken to prevent charging current passing through them.

23.8 Leakage

All cells shall be constructed, or arranged so as to prevent leakage of electrolyte, which would adversely affect the type of protection or components on which safety depends.

23.9 Connections

Only the manufacturer's recommended method(s) of making electrical connections to a battery shall be used.

23.10 Orientation

Where a battery is mounted inside equipment and the battery orientation is important for safe operation, the correct orientation of the equipment shall be indicated on the outside of the equipment enclosure.

NOTE Correct orientation of the battery is often important to prevent electrolyte leakage.

23.11 Replacement of cells or batteries

Where it is necessary for the user to replace cells or batteries contained within an enclosure, the relevant parameters to allow correct replacement shall be legibly and durably marked on or inside the enclosure as detailed in 29.14, or detailed in the manufacturer's instructions in

accordance with 30.2. That is, either the manufacturer's name and part number, or the electrochemical system, nominal voltage and rated capacity.

23.12 Replaceable battery pack

Where it is intended for the user to replace the battery pack, the battery pack shall be legibly and durably marked on the outside of the battery pack as detailed in 29.14.

Replaceable battery packs shall be either:

- located completely inside the equipment enclosure
- connected to the equipment and shall comply with the requirements for the applicable type of protection when disconnected from the equipment and shall be marked per item b) of 29.12, or
- connected to the equipment and shall employ disconnecting means that comply with the requirements of Clause 20.

The battery pack replacement details shall be included in the manufacturer's instructions in accordance with 30.2.

24 Documentation

The manufacturer shall prepare documents that give a full and correct specification of the explosion safety aspects of the electrical equipment.

25 Compliance of prototype or sample with documents

The prototypes or samples of the electrical equipment subjected to the type verifications and tests shall comply with the manufacturer's documents referred to in Clause 24.

26 Type tests

26.1 General

The prototypes or samples shall be tested in accordance with the requirements for type tests of this standard and of the specific standards for the types of protection concerned. However, certain tests judged to be unnecessary, may be omitted from the testing programme. A record shall be made of all tests carried out and of the justification for those omitted.

It is not necessary to repeat the tests that have already been carried out on an Ex Component.

NOTE Due to the safety factors incorporated in the types of protection, the uncertainty of measurement inherent in good quality, regularly calibrated measurement equipment is considered to have no significant detrimental effect and need not be taken into account when making the measurements necessary to verify compliance of the equipment with the equipment requirements of the relevant part of IEC 60079.

26.2 Test configuration

Each test shall be made in the configuration of the electrical equipment considered to be the most unfavourable.

26.3 Tests in explosive test mixtures

Tests in explosive mixtures shall be carried out as specified in relevant standards listed in Clause 1.

NOTE The purity of commercially available gases and vapours is in general satisfactory for these tests but, if their purity is below 95 %, they should not be used. The effects of normal variations in the laboratory temperature and of atmospheric pressure and the effects of variations in the humidity of the explosive test mixture are acceptable because they have been found to have negligible effect.

26.4 Tests of enclosures

26.4.1 Order of tests

26.4.1.1 Metallic enclosures, metallic parts of enclosures and glass parts of enclosures

Tests for metallic enclosures, metallic parts of enclosures and glass parts of enclosures shall be performed in the following order:

- tests for resistance to impact (see 26.4.2);
- drop test, if applicable (see 26.4.3);
- tests for degrees of protection (IP) (see 26.4.5);
- any other tests required by this standard;
- any other test specific to the type of protection concerned.

Tests shall be made on the number of samples specified by each test method.

NOTE Where the degree of protection IP is provided by non-metallic sealing materials, other than glass or ceramics, the requirements of 26.4.1.2 will apply.

26.4.1.2 Non-metallic enclosures or non-metallic parts of enclosures

Tests for non-metallic enclosures or non-metallic parts of enclosures shall be performed in the following order. See Annex F for a flowchart providing guidance on the order of tests.

26.4.1.2.1 Group I electrical equipment

The tests shall be made on samples as follows:

- Four samples shall be used. All four samples shall be submitted to the tests of thermal endurance to heat (see 26.8), then to thermal endurance to cold (see 26.9). Two samples shall then be submitted to the tests for resistance to impact (see 26.4.2), with the tests being conducted at the 'upper test temperature' (see 26.7.2). The other two samples shall also be submitted to the tests for resistance to impact (see 26.4.2), then to the drop test if applicable (see 26.4.3), but with the tests being conducted at the 'lower test temperature' (see 26.7.2). Any joint that is intended to be opened during installation or in normal operation shall be opened and re-closed in accordance with the manufacturer's instructions. Subsequently, all four samples shall be submitted to the tests for degree of protection by enclosures (see 26.4.5), and then subjected to the appropriate tests specific to the type of protection concerned.
- Alternatively, only two samples may be used. In this case, both samples shall be submitted to the tests of thermal endurance to heat (see 26.8), then to thermal endurance to cold (see 26.9). Both samples shall then be submitted to the tests for resistance to impact (see 26.4.2), with the tests being conducted at the "upper test temperature" (see 26.7.2). Thereafter, both samples shall also be submitted to the tests for resistance to impact (see 26.4.2), then to the drop test if applicable (see 26.4.3), but with the tests now being conducted at the 'lower test temperature' (see 26.7.2). Any joint that is intended to be opened during installation or in normal operation shall be opened and re-closed in accordance with the manufacturer's instructions. Subsequently, both samples shall be submitted to the tests for degree of protection by enclosures (see 26.4.5), and then subjected to the appropriate tests specific to the type of protection concerned.

NOTE As a result of the thermal endurance testing for either of the test sequences described above, condensation may occur inside the enclosure. Such condensation will need to be removed prior to ingress protection (IP) testing to ensure valid results.

- Two samples shall be submitted to the tests of resistance to oils and greases (see 26.11) then to the tests for resistance to impact (see 26.4.2), then to the drop test if applicable (see 26.4.3), then the tests for degrees of protection (IP) if applicable (see 26.4.5), and finally to the tests specific to the type of protection concerned.
- Two samples shall be submitted to the tests of resistance to hydraulic liquids for mining applications (see 26.11) then to tests for resistance to impact (see 26.4.2), then to the drop test if applicable (see 26.4.3), then the tests for degrees of protection (IP) if applicable (see 26.4.5), and finally to the tests specific to the type of protection concerned.

In the procedures and test sequences described above the objective is to demonstrate the ability of the non-metallic material to maintain the specific type of protection listed in Clause 1 after exposure to extremes of temperature and harmful substances likely to be met in use. In an attempt to keep the number of tests to a minimum, it is not necessary to perform all of the tests specific to the type of protection on every sample if it is obvious that a sample has not been damaged in such a way as to impair the type of protection offered. Similarly, the number of samples can be reduced if it is possible for the exposure tests and protection-proving tests to be performed in parallel on the same two samples.

26.4.1.2.2 Group II and Group III electrical equipment

Four samples shall be used. All four samples shall be submitted to the tests of thermal endurance to heat (see 26.8), then to thermal endurance to cold (see 26.9). Two samples shall then be submitted to the tests for resistance to impact (see 26.4.2), with the tests being conducted at the 'upper test temperature' (see 26.7.2). The other two samples shall also be submitted to the tests for resistance to impact (see 26.4.2), then to the drop test if applicable (see 26.4.3), but with the tests being conducted at the 'lower test temperature' (see 26.7.2). Any joint that is intended to be opened during installation or in normal operation shall be opened and re-closed in accordance with the manufacturer's instructions. Subsequently, all four samples shall be submitted to the tests for degree of protection by enclosures (see 26.4.5), and then subjected to the appropriate tests specific to the type of protection concerned.

Alternatively, only two samples may be used. In this case, both samples shall be submitted to the tests of thermal endurance to heat (see 26.8), then to thermal endurance to cold (see 26.9). Both samples shall then be submitted to the tests for resistance to impact (see 26.4.2), with the tests being conducted at the 'upper test temperature' (see 26.7.2). Thereafter, both samples shall also be submitted to the tests for resistance to impact (see 26.4.2), then to the drop test if applicable (see 26.4.3), but with the tests now being conducted at the 'lower test temperature' (see 26.7.2). Any joint that is intended to be opened during installation or in normal operation shall be opened and re-closed in accordance with the manufacturer's instructions. Subsequently, both samples shall be submitted to the tests for degree of protection by enclosures (see 26.4.5), and then subjected to the appropriate tests specific to the type of protection concerned.

NOTE As a result of the thermal endurance testing for either of the test sequences described above, condensation may occur inside the enclosure. Such condensation will need to be removed prior to ingress protection (IP) testing to ensure valid results.

26.4.2 Resistance to impact

The electrical equipment shall be submitted to the effect of a test mass of 1 kg falling vertically from a height h . The height h is specified in Table 13 according to the application of the electrical equipment. The mass shall be fitted with an impact head made of hardened steel in the form of a hemisphere of 25 mm diameter.

Before each test, it is necessary to check that the surface of the impact head is in good condition.

The resistance to impact test shall be made on electrical equipment which is completely assembled and ready for use; however, if this is not possible (for example, for light-

transmitting parts), the test shall be made with the relevant parts removed but fixed in their mounting or an equivalent frame. Tests on an empty enclosure are permitted with appropriate justification in the documentation (see Clause 24).

The test shall be made on at least two samples. For light-transmitting parts made of glass, the test shall be made only once on each sample. In all other cases, the test shall be made at two separate places on each sample, see 26.4.1.

The points of impact shall be the places considered to be the weakest and shall be on the external parts which may be exposed to impact. If the enclosure is protected by another enclosure, only the external parts of the assembly shall be subjected to the resistance to impact tests.

The electrical equipment shall be mounted on a steel base so that the direction of the impact is normal to the surface being tested if it is flat, or normal to the tangent to the surface at the point of impact if it is not flat. The base shall have a mass of at least 20 kg or be rigidly fixed or inserted in the floor, for example, secured in concrete. Annex C gives an example of a suitable test rig.

When the impact head strikes the test sample, it may exhibit one or more "bounces". The impact head shall not be removed from the surface of the test sample until it has come to rest.

Table 13 – Tests for resistance to impact

Equipment grouping	Drop height $h_{+0,01}^0$ with $1_{+0,01}^0$ kg mass			
	Group I		Group II or III	
Risk of mechanical danger	High	Low	High	Low
a) Enclosures and external accessible parts of enclosures (other than light-transmitting parts)	2	0,7	0,7	0,4
b) Guards, protective covers, fan hoods, cable glands	2	0,7	0,7	0,4
c) Light-transmitting parts without guard	0,7	0,4	0,4	0,2
d) Light-transmitting parts with guard having individual openings from 625 mm ² to 2 500 mm ² ; see 21.1 (tested without guard)	0,4	0,2	0,2	0,1
NOTE A guard for light-transmitting parts having individual openings from 625 mm ² to 2 500 mm ² reduces the risk of impact, but does not prevent impact.				

When, at the request of the manufacturer, electrical equipment is submitted to tests corresponding to the low risk of mechanical danger, it shall be marked with the symbol "X" to indicate this specific condition of use in accordance with item e) of 29.3.

The test shall be carried out at an ambient temperature of (20 ± 5) °C, except where the material data shows it to have a reduction in resistance to impact at lower temperatures within the specified ambient range. In this case, the test shall be performed at the lower test temperature, in accordance with 26.7.2.

When the electrical equipment has an enclosure or a part of an enclosure made of a non-metallic material, including non-metallic fan hoods and ventilation screens in rotating electrical machines, the test shall be carried out at the upper and lower test temperatures, in accordance with 26.7.2.

26.4.3 Drop test

In addition to being submitted to the resistance to impact test in accordance with 26.4.2, hand-held electrical equipment or electrical equipment carried on the person, ready for use, shall be dropped four times from a height of at least 1 m onto a horizontal concrete surface. The position of the sample for the drop test shall be that which is considered to be the most unfavourable.

The drop test shall be conducted with any replaceable battery pack connected to the equipment.

For electrical equipment with an enclosure which is of a metallic material, the test shall be carried out at a temperature of $(20 \pm 5) ^\circ\text{C}$, except where the material data shows it to have a reduction in resistance to impact at lower temperatures within the specified ambient range. In this case, the test shall be performed at the lower test temperatures, in accordance with 26.7.2.

For electrical equipment which has enclosures or parts of enclosures made of non-metallic material, the tests shall be carried out at the lower test temperature in accordance with 26.7.2.

26.4.4 Acceptance criteria

The resistance to impact and drop tests shall not produce damage so as to invalidate the type of protection of the electrical equipment.

Superficial damage, chipping to paint work, breakage of cooling fins or other similar parts of the electrical equipment and small dents shall be ignored.

External fan hoods and ventilation screens shall resist the tests without displacement or deformation causing contact with the moving parts.

26.4.5 Degree of protection (IP) by enclosures

26.4.5.1 Test procedure

When a degree of protection is required by this standard or by other parts of this series for a specific type of protection, the test procedures shall be in accordance with IEC 60529, except for rotating electrical machines which shall be in accordance with IEC 60034-5.

When tested in accordance with IEC 60529,

- enclosures shall be considered as belonging to “Category 1 enclosure” as specified in IEC 60529,
- the equipment shall not be energized,
- where applicable, the dielectric test specified in IEC 60529 shall be carried out at $[(2 U_n + 1\,000) \pm 10\%] \text{ V r.m.s.}$ applied between 10 s and 12 s, where U_n is the maximum rated or internal voltage of the equipment.

NOTE The “category 1 enclosure” is defined in IEC 60529 and bears no relation to the “category 1” defined in the European directive 94/9/EC (ATEX).

When tested in accordance with IEC 60034-5,

- the rotating electrical machine shall not be energized,

26.4.5.2 Acceptance criteria

For electrical equipment tested in accordance with IEC 60529, the acceptance criteria shall be in accordance with IEC 60529 except where the manufacturer specifies acceptance criteria more onerous than those described in IEC 60529, for example, those in a relevant product standard. In this case, the acceptance criteria of the relevant product standard shall be applied unless it adversely affects explosion protection.

The acceptance criteria in IEC 60034-5 shall be applied to rotating electrical machines insofar as compliance with an IEC explosion protection standard is concerned in addition to the conditions specified in IEC 60034-5.

Where a standard for electrical equipment for explosive atmospheres specifies acceptance criteria for IPXX, these shall be applied instead of those in IEC 60529 or IEC 60034-5.

26.5 Thermal tests

26.5.1 Temperature measurement

26.5.1.1 General

For electrical equipment which can normally be used in different positions, the temperature in each position shall be considered. When the temperature is determined for certain positions only, the electrical equipment shall be marked with the symbol "X" to indicate this specific condition of use according to item e) of 29.3.

NOTE 1 Equipment that is likely to exist in uncontrolled positions, the use of the symbol "X" is not appropriate. For example, mining headlamps can operate for quite some time at angles that are not foreseen in normal operation (vertical) and can reach excessive temperatures.

The measuring devices (thermometers, thermocouples, etc.) and the connecting cables shall be selected and so arranged that they do not significantly affect the thermal behaviour of the electrical equipment.

The final temperature shall be considered to have been reached when the rate of rise of temperature does not exceed 2 K/h.

For electrical equipment of Group III evaluated with a dust layer in accordance with 5.3.2.3.2, the equipment to be tested shall be mounted in accordance with the instructions and surrounded on all available surfaces by a dust thickness at least equal to the specified layer depth L . The measurement for the maximum surface temperature shall be determined using a test dust having a thermal conductivity of no more than 0,10 W/(m×K) measured at (100 ± 5) °C.

NOTE 2 Unless the manufacturer has specified a range of supply frequencies, it may be assumed that normal tolerances both of the supply in use and of the supply for test purposes is sufficiently small to be ignored.

NOTE 3 Some equipment may require the provision of integral temperature sensitive devices to limit temperatures.

26.5.1.2 Service temperature

The test to determine service temperatures shall be made at the rated voltage of the electrical equipment but without considering malfunctions.

The temperature of the hottest point of any non-metallic enclosures or non-metallic part of enclosure upon which the type of protection depends (see 7.1) shall be determined.

Where the input voltage does not directly affect the temperature rise of the equipment or Ex Component, such as a terminal or a switch, the test current shall be 100 % of the rated current.

NOTE Where equipment rating is a range (e.g. 100-250 V), the testing should be performed at the highest or lowest value in the range, whichever results in the higher temperature rise.

26.5.1.3 Maximum surface temperature

The test to determine maximum surface temperature shall be performed under the most adverse ratings with an input voltage between 90 % and 110 % of the rated voltage of the electrical equipment that gives the maximum surface temperature.

For electrical machines, determination of the maximum surface temperature may alternatively be conducted at the worst case test voltage within "Zone A" per IEC 60034-1. In this case, the equipment shall be marked with the symbol "X" in accordance with item e) of 29.3 and the specific condition of use shall include the information that the surface temperature determination was based on operation within "Zone A" (IEC 60034-1), typically ± 5 % of rated voltage. For electrical machines operated from a converter, the test voltage variation, for maximum surface temperature determination shall be applied to the motor-converter system as a whole, i.e. applied to the converter input, not the motor input. See Annex E for additional information on the temperature rise testing of electric machines.

Where the input voltage does not directly affect the temperature rise of the equipment or Ex Component, such as a terminal or a switch, the test current shall be increased to 110 % of the rated current.

The tests to determine maximum surface temperature shall be performed without consideration of malfunctions unless specific malfunctions are specified by the requirements for the specific type of protection.

NOTE 1 Where equipment rating is a range (e.g. 100-250 V), the test should be performed at 90 % of the lowest value in the range or at 110 % of the highest value in the range, whichever results in the higher temperature rise.

NOTE 2 Unless the manufacturer has specified a range of supply frequencies, it may be assumed that normal tolerances both of the supply in use and of the supply for test purposes is sufficiently small to be ignored.

NOTE 3 Due to the voltage regulation properties of a converter, voltage variations at the input to the converter do not directly result in voltage variations at the output of the converter.

The measured maximum surface temperature shall not exceed:

- for Group I equipment, those values as given in 5.3.2.1,
- for Group II equipment subjected to type testing for maximum surface temperature, the marked temperature or temperature class, less 5 K for temperature classes T6, T5, T4 and T3 (or marked temperatures ≤ 200 °C), and less 10 K for temperature classes T2 and T1 (or marked temperatures > 200 °C), Alternatively, for Group II equipment subjected to routine testing for maximum surface temperature, the temperature or temperature class marked on the electrical equipment,
- for Group III equipment, those values assigned, see 5.3.2.3.

26.5.2 Thermal shock test

Glass parts of luminaires and windows of electrical equipment shall withstand, without breaking, a thermal shock caused by a jet of water of about 1 mm diameter at a temperature (10 ± 5) °C sprayed on them when they are at not less than the maximum service temperature.

NOTE This "jet of water" is frequently applied using a small (~ 10 cm³) syringe with 10 °C water. Neither the distance from which the jet is applied, nor the pressure of application are considered to have a significant effect on the results.

26.5.3 Small component ignition test (Group I and Group II)

26.5.3.1 General

A small component tested to demonstrate that it shall not cause temperature ignition of a flammable mixture in accordance with item a) of 5.3.3, shall be tested in the presence of a specified gas/air mixture as described in 26.5.3.2.

26.5.3.2 Procedure

The test shall be carried out with the component either

- mounted in the equipment as intended and precautions shall be taken to ensure that the test mixture is in contact with the component, or
- mounted in a model which ensures representative results. In this case, such a simulation shall take into account the effect of other parts of the equipment in the vicinity of the component being tested which affect the temperature of the mixture and the flow of the mixture around the component as a result of ventilation and thermal effects.

The component shall be tested under normal operation, or under the malfunction conditions specified in the standard for the type of protection which produces the highest value of surface temperature. The test shall be continued either until thermal equilibrium of the component and the surrounding parts is attained or until the component temperature drops. Where component failure causes the temperature to fall, the test shall be repeated five times using five additional samples of the component. Where, in normal operation or under the malfunction conditions specified in the standard for the type of protection, the temperature of more than one component exceeds the temperature class of the equipment, the test shall be carried out with all such components at their maximum temperature.

The safety margin required by 5.3.3 shall be achieved either by raising the ambient temperature at which the test is carried out or, where this is possible, by raising the temperature of the component under test and other relevant adjacent surfaces by the required margin.

For Group I, the test mixture shall be a homogenous mixture between 6,2 % and 6,8 %, v/v methane and air.

For T4 temperature classification, the mixture shall be either

- a) a homogeneous mixture of between 22,5 % and 23,5 % v/v diethyl ether and air, or
- b) a mixture of diethyl ether and air obtained by allowing a small quantity of diethyl ether to evaporate within a test chamber while the ignition test is being carried out.

For other temperature classifications, the choice of suitable test mixtures shall be at the discretion of the testing station.

26.5.3.3 Acceptance criteria

The appearance of a cool flame shall be considered as an ignition. Detection of ignition shall either be visual or by measurement of temperature, for example, by a thermocouple.

If no ignition occurs during a test, the presence of the flammable mixture shall be verified by igniting the mixture by some other means.

26.6 Torque test for bushings

26.6.1 Test procedure

Bushings used for connection facilities and which are subjected to torque during connection or disconnection of conductors shall be tested for resistance to torque.

The stem in the bushing, or the bushing when mounted, shall be subjected to a torque of the value given in Table 14.

Table 14 – Torque to be applied to the stem of bushing used for connection facilities

Diameter of the stem of the bushings	Torque Nm
M 4	2,0
M 5	3,2
M 6	5
M 8	10
M 10	16
M 12	25
M 16	50
M 20	85
M 24	130

NOTE Torque values for sizes other than those specified above may be determined from a graph plotted using these values. In addition, the graph may be extrapolated to allow torque values to be determined for stems of bushings larger than those specified.

26.6.2 Acceptance criteria

When mounted, neither the stem in the bushing, nor the bushing itself, shall turn when the stem is subjected to a torque.

26.7 Non-metallic enclosures or non-metallic parts of enclosures

26.7.1 General

In addition to the relevant tests given in 26.1 to 26.6, non-metallic enclosures shall also satisfy the requirements in 26.8 to 26.15, as appropriate. The tests of 26.10 to 26.15 are independent tests performed on separate samples that are not required to be part of the test sequence for tests of enclosures, 26.4. Non-metallic parts of enclosures shall be tested together with the whole enclosure or with a representative model of the enclosure.

26.7.2 Test temperatures

When, according to this standard or to the specific standards listed in Clause 1, tests have to be carried out as a function of the permissible upper and lower service temperature, these test temperatures shall be

- for the upper temperature, the maximum service temperature (see 5.2) increased by at least 10 K but at most 15 K,
- for the lower temperature, the minimum service temperature (see 5.2) reduced by at least 5 K but at most 10 K.

26.8 Thermal endurance to heat

The thermal endurance to heat shall be determined by submitting the enclosures or parts of enclosures in non-metallic materials, on which the integrity of the type of protection depends, to tests according to Table 15.

Table 15 – Thermal endurance test

Service temperature T_s	Test condition	Alternative test condition
$T_s \leq 70 \text{ }^\circ\text{C}$	672 ₊₃₀ ⁰ h at (90 ± 5) % RH, at $T_s + 20 \pm 2 \text{ K}$ (but not less than 80 °C test temperature)	
$70 \text{ }^\circ\text{C} < T_s \leq 75 \text{ }^\circ\text{C}$	672 ₊₃₀ ⁰ h at (90 ± 5) % RH at $T_s + 20 \pm 2 \text{ K}$	504 ₊₃₀ ⁰ h at (90 ± 5) % RH at (90 ± 2) °C followed by 336 ₊₃₀ ⁰ h dry at $T_s + 20 \pm 2 \text{ K}$
$T_s > 75 \text{ }^\circ\text{C}$	336 ₊₃₀ ⁰ h at (90 ± 5) % RH at (95 ± 2) °C, followed by 336 ₊₃₀ ⁰ h dry at $T_s + 20 \pm 2 \text{ K}$	504 ₊₃₀ ⁰ h at (90 ± 5) % RH at (90 ± 2) °C followed by 336 ₊₃₀ ⁰ h dry at $T_s + 20 \pm 2 \text{ K}$
<p>T_s is the temperature defined in 5.2 and shall NOT include the increase stated in 26.7.2.</p>		

At the conclusion of the test according to Table 15, the enclosures or parts of enclosures in non-metallic materials that were tested shall be subjected to $(20 \pm 5) \text{ }^\circ\text{C}$ at $(50 \pm 10) \%$ relative humidity for 24₊₄₈⁰ h, and then immediately followed by the thermal endurance to cold test (26.9).

NOTE The test values given in Table 15 include two test conditions. The conditions shown in the 2nd column were used in previous editions of this standard and allow previously obtained test results to remain valid for this edition. The conditions shown in the 3rd column have been added to allow testing at temperature/humidity conditions that are more readily achieved, although at an increased test time.

NOTE It is generally acknowledged that glass and ceramic materials are not adversely affected by the thermal endurance to heat test, and testing may not be necessary.

26.9 Thermal endurance to cold

The thermal endurance to cold shall be determined by submitting the enclosures and parts of enclosures of non-metallic materials, on which the type of protection depends, to storage for 24 h₊₂⁰ in an ambient temperature corresponding to the minimum service temperature reduced according to 26.7.2.

NOTE It is generally acknowledged that glass and ceramic materials are not adversely affected by the thermal endurance to cold test, and testing may not be necessary.

26.10 Resistance to light

26.10.1 Test procedure

The test shall be made on six test bars of standard size $(80 \pm 2) \text{ mm} \times (10 \pm 0,2) \text{ mm} \times (4 \pm 0,2) \text{ mm}$ according to ISO 179. The test bars shall be made under the same conditions as those used for the manufacture of the enclosure concerned; these conditions are to be stated in the test report of the electrical equipment.

NOTE 1 An additional six bars may be required to be able to determine the impact bending strength on unexposed samples.

The test shall be made generally in accordance with ISO 4892-2 in an exposure chamber using a xenon lamp and a sunlight simulating filter system. The sample shall be exposed, without cycling, under dry conditions and at either a black standard temperature of $(65 \pm 3) ^\circ\text{C}$ or a black panel temperature of $(55 \pm 3) ^\circ\text{C}$ for between 1000 h and 1025 h.

NOTE 2 The value of $65 ^\circ\text{C}$ black standard temperature is selected for compatibility with tests being performed in equipment specifically designed to operate in accordance with ISO 4892-2. The value of $55 ^\circ\text{C}$ black panel temperature is selected to ensure compatibility with results obtained for previous editions of IEC 60079-0. According to ISO 4892-2, both conditions are nearly identical, but there may be minor differences too small to be relevant for the purpose of this test

Where the preparation of test samples in accordance with ISO 179 is not practical due to the nature of the non-metallic material, an alternative test shall be permitted with the justification stated in the test report for the electrical equipment:

26.10.2 Acceptance criteria

The evaluation criterion is the impact bending strength in accordance with ISO 179. The impact bending strength following exposure in the case of an impact on the exposed side shall be at least 50 % of the corresponding value measured on the unexposed test pieces. For materials whose impact bending strength cannot be determined prior to exposure because no rupture has occurred, not more than three of the exposed test bars shall be allowed to break.

26.11 Resistance to chemical agents for Group I electrical equipment

The non-metallic enclosures and non-metallic parts of enclosures shall be submitted to tests of resistance to the following chemical agents:

- oils and greases;
- hydraulic liquids for mining applications.

The relevant tests shall be made on four samples of enclosure sealed against the intrusion of test liquids into the interior of the enclosure:

- two samples shall remain for (24 ± 2) h in oil No. 2 according to the annex "Reference liquids" of ISO 1817, at a temperature of $(50 \pm 2) ^\circ\text{C}$;
- the other two samples shall remain for (24 ± 2) h in fire-resistant hydraulic fluid intended for operating at temperatures between $-20 ^\circ\text{C}$ and $+60 ^\circ\text{C}$, comprising an aqueous solution of polymer in 35 % water at a temperature of $(50 \pm 2) ^\circ\text{C}$.

At the end of the test, the enclosure samples concerned shall be removed from the liquid bath, carefully wiped and then stored for (24 ± 2) h in the laboratory atmosphere. Subsequently, each of the enclosure samples shall pass the tests of enclosures according to 26.4.

If one or more of the enclosure samples do not withstand these tests of enclosures after exposure to one or more of the chemicals, the enclosure shall be marked with the symbol "X" to indicate this specific condition of use according to item e) of 29.3, i.e. exclusion of exposure to specific chemicals during use.

26.12 Earth continuity

The material from which the enclosure is manufactured may be tested as a complete enclosure, part of an enclosure, or as a sample of the material from which the enclosure is made, provided that the relevant critical dimensions of the sample are the same as those of the enclosure.

The cable gland shall be represented by a 20 mm (nominal) diameter test bar manufactured from brass ($\text{CuZn}_{39}\text{Pb}_3$ or $\text{CuZn}_{38}\text{Pb}_4$) carrying an ISO metric thread with a tolerance class 6g, 1,5 mm pitch in accordance with IEC 60423. The length of the test bar shall ensure

that at least one full thread remains free at each end when assembled, as shown in the diagram.

Complete earth plates or parts of earth plates that are intended to be used with the enclosure shall be used for the purpose of this test. A clearance hole shall be provided in the earth plate for test purposes and shall be between 22 mm and 23 mm diameter. The method of assembly shall ensure that the screw thread of the test bar does not make contact directly with the inside of the clearance hole.

The clamping nuts shall be manufactured from brass ($\text{CuZn}_{36}\text{Pb}_3$ or $\text{CuZn}_{38}\text{Pb}_4$) and shall be provided with an ISO metric thread with a tolerance class 6H, 1,5 mm pitch in accordance with IEC 60423. The thickness of the nuts shall be 2 mm (nominal) and the dimension across the flats shall be 27 mm maximum.

The components are assembled as shown in Figure 4. The torque applied to each pair of the nuts, in turn, shall be 10 N·m (+10 %).

The hole in the wall (or part of the wall or the test sample) may be a plain through-hole or a tapped hole having a thread form compatible with the test bar.

After the test sample has been assembled it shall be subjected to the conditions for the test for thermal endurance to heat as described in 26.8.

This shall be followed by a further period of 14 days in an air oven at a temperature of 80 °C.

On completion of conditioning, the resistance between the earth plates or parts of earth plates shall be calculated by passing a direct current of 10 A to 20 A between the earth plates and measuring the voltage drop between them.

The non-metallic material that has been tested in this manner is deemed to be satisfactory if the resistance between the earth plates or parts of earth plates does not exceed $5 \times 10^{-3} \Omega$.

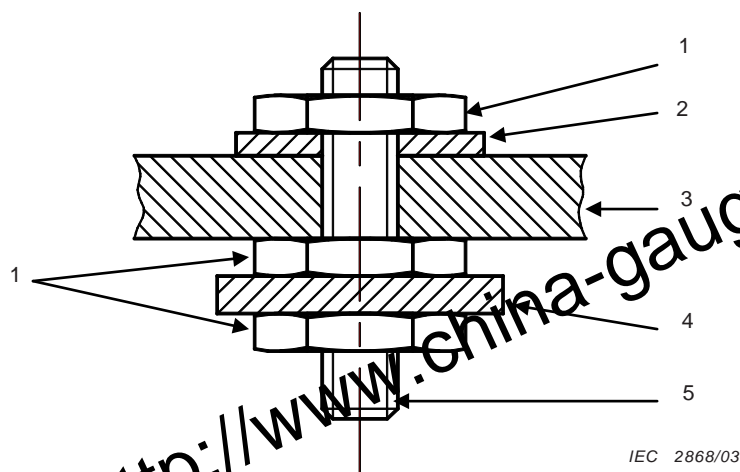

Components

- | | |
|--------------------------------------|------------|
| 1 nut | 5 test bar |
| 2 earth plate | |
| 3 enclosure wall (non-metallic) | |
| 4 earth plate or part of earth plate | |

Figure 4 – Assembly of test sample for earth-continuity test

26.13 Surface resistance test of parts of enclosures of non-metallic materials

The surface resistance shall be tested on the parts of enclosures if size permits, or on a test piece comprising a rectangular plate with dimensions in accordance with Figure 5. The test piece shall have an intact clean surface. Two parallel electrodes are painted on the surface, using a conducting paint with a solvent which has no significant effect on the surface resistance.

The test piece shall be cleaned with distilled water, then with isopropyl alcohol (or any other solvent that can be mixed with water and will not affect the material of the test piece or the electrodes), then once more with distilled water before being dried. Untouched by bare hands, it shall then be conditioned for at least 24 h at (23 ± 2) °C and (50 ± 5) % or (30 ± 5) % relative humidity, as applicable (See 7.4.2.a). The test shall be carried out under the same ambient conditions.

The direct voltage applied for (65 ± 5) s between the electrodes shall be (500 ± 10) V.

During the test, the voltage shall be sufficiently steady so that the charging current due to voltage fluctuation will be negligible compared with the current flowing through the test piece.

The surface resistance is the quotient of the direct voltage applied at the electrodes to the total current flowing between them.

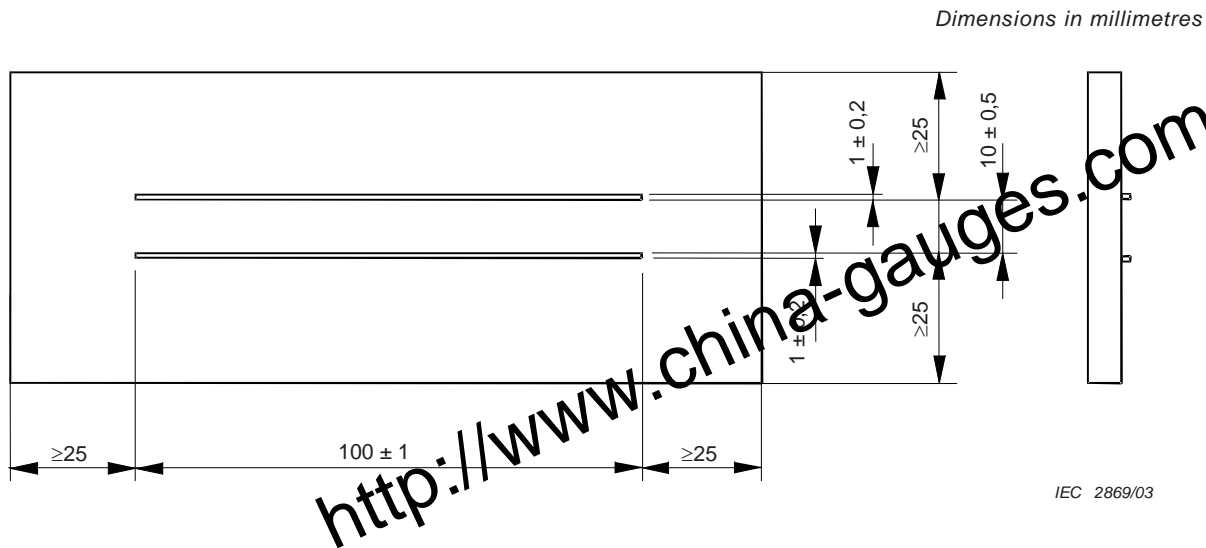

Figure 5 – Test piece with painted electrodes

26.14 Measurement of capacitance

26.14.1 General

The test shall be carried out on a fully assembled sample of the electrical equipment. The sample need not have been previously subjected to the tests for enclosures. The sample shall be conditioned in a climatic conditioning chamber for at least 1 h at a temperature of $(23 \pm 2) ^\circ\text{C}$ and a relative humidity of $(50 \pm 5) \% \text{RH}$. The sample under test shall be placed on an unearthed metal plate that significantly exceeds the area of the test sample. If the sample requires support, it may be held in position with clamps or pliers (preferably made of plastic), but shall not be held by hand. Other electrical equipment shall be kept as far as possible from the test sample. Connection leads shall be as short as possible. The positions of the samples are to be such that the exposed metallic test point being measured is as close as possible to the unearthed metal plate without contacting the plate. However, if the external metal part is in electrical contact with internal metal parts, it is necessary to measure the capacitance in all orientations of the equipment to ensure that the maximum capacitance has been determined.

NOTE Metallic plates with surface oxidation should be avoided as this may lead to erroneous results.

26.14.2 Test procedure

The capacitance between each exposed metallic part on the test sample and the metal plate is to be measured. Connect the negative measurement lead of the capacitance meter to the unearthed metal plate. The positive measurement lead of the capacitance meter should be kept as far as possible from the metal plate.

NOTE 1 A battery powered capacitance meter may be necessary to ensure stable readings.

NOTE 2 If a metallic part is not easily accessible to the meter leads, a screw may be inserted to extend the part and create a test point. The screw should not make electrical contact with any other internal metal part.

NOTE 3 Stray capacitance should be minimized. Other electrical equipment should be kept as far away as possible.

The test procedure for the capacitance measurement is as follows:

- 1) Position the positive measurement probe of the capacitance meter 3 to 5 mm away from the metallic test point. Record the value of this stray capacitance in air to the nearest pF.
- 2) Place the positive measurement lead of the capacitance meter in contact with the metallic test point and record the value of the capacitance to the nearest pF.

- 3) Compute the difference between the measurements in steps 1) and 2), and record the value.
- 4) Repeat steps 1) through 3) two times for each test point.
- 5) Calculate the average capacitance from the three measurements obtained.

26.15 Verification of ratings of ventilating fans

☒ For Group I equipment, the applicable requirements of EN 1710 shall be applied.

For Group II and Group III equipment, all requirements of EN 1385 shall be applied. ☒

26.16 Alternative qualification of elastomeric sealing O-rings

The thickness t_0 of the sealing ring is measured at $(20 \pm 5)^\circ\text{C}$ temperature. The ring is then compressed as intended in the complete equipment enclosure or in the test fixture.

The compressed sealing ring is then submitted to the tests for thermal endurance to heat (26.8) and thermal endurance to cold (26.9). The sealing ring shall then be removed from the adapter, or equipment, and be kept for at least 24 h_{+2}^0 at a temperature of $(20 \pm 5)^\circ\text{C}$ before the thickness t_1 of the O-ring is measured.

The compression set value c shall be calculated as follows:

$$c = (t_0 - t_1) / (t_0 - t_s) \times 100$$

t_0 is the initial thickness of the sealing ring measured at $(20 \pm 5)^\circ\text{C}$ temperature

t_s is the thickness of the sealing ring when compressed as intended in the equipment.

t_1 is the thickness of the sealing ring measured at $(20 \pm 5)^\circ\text{C}$ temperature after thermal endurance.

NOTE The compression set value describes the ability for the sealing ring to return to its initial dimension after being subject to compression.

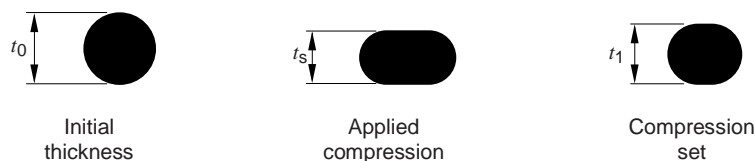

IEC 1141/11

Figure 6 – Compression set of an O-ring

27 Routine tests

The manufacturer shall also carry out any routine tests required by any of the standards listed in Clause 1 which were used for the examination and testing of the equipment.

28 Manufacturer's responsibility

28.1 Conformity with the documentation

The manufacturer shall carry out the verifications or tests necessary to ensure that the electrical equipment produced complies with the documentation.

NOTE It is not the intent of this subclause to require 100 % inspection of parts. Statistical methods may be employed to verify compliance.

28.2 Certificate

The manufacturer shall prepare, or have prepared, a certificate confirming that the equipment is in conformity with the requirements of this standard along with its other applicable parts and additional standards mentioned in Clause 1. The certificate can relate to Ex equipment or an Ex Component.

An Ex Component certificate (Identified by the symbol "U" suffix to the certificate number) is prepared for parts of equipment that are incomplete and require further evaluation prior to incorporation in Ex equipment. The Ex Component certificate may include a Schedule of Limitations detailing specific additional evaluation required as part of incorporation into Ex equipment. An Ex Component certificate shall clarify that it is not an Ex equipment certificate.

28.3 Responsibility for marking

By marking the electrical equipment in accordance with Clause 29, the manufacturer attests on his own responsibility that

- the electrical equipment has been constructed in accordance with the applicable requirements of the relevant standards in safety matters,
- the routine verifications and routine tests in 28.1 have been successfully completed and that the product complies with the documentation.

29 Marking

29.1 Applicability

It is essential that the system of marking indicated below only be applied to electrical equipment or Ex Components which comply with the applicable standards for the types of protection listed in Clause 1.

29.2 Location

The electrical equipment shall be legibly marked on a main part on the exterior of the equipment and shall be visible prior to the installation of the equipment.

NOTE 1 The marking should be in a location that is likely to be visible after installation of the equipment.

NOTE 2 Where the marking is located on a removable part of the equipment, a duplicated marking on the interior of the equipment may be useful during installation and maintenance by helping to avoid confusion with similar equipment. See 29.11 for additional guidance on extremely small equipment and Ex Components.

29.3 General

The marking shall include the following:

- Ⓒ₁₁ a) the name and address of the manufacturer; Ⓒ₁₁
- b) the manufacturer's type identification;
- c) a serial number, except for
 - connection accessories (cable glands, blanking element, thread adaptor and bushings);
 - very small electrical equipment on which there is limited space;(The batch number can be considered to be an alternative to the serial number.)
- d) the name or mark of the certificate issuer and the certificate reference in the following form: the last two figures of the year of the certificate followed by a "." followed by a unique four character reference for the certificate in that year;

NOTE 1 For some regional third-party certification, the separating character “.” may be replaced by another separating designator such as “ATEX”.

- e) if it is necessary to indicate specific conditions of use, the symbol “X” shall be placed after the certificate reference. An advisory marking may appear on the equipment as an alternative to the requirement for the “X” marking;

NOTE 2 The advisory marking may be a specific reference to a specific instruction document containing the detailed information.

NOTE 3 The manufacturer should ensure that the requirements of the specific conditions of use are passed to the purchaser together with any other relevant information.

- f) the specific Ex marking for explosive gas atmospheres, see 29.4, or for explosive dust atmospheres, see 29.5. The Ex marking for explosive gas atmospheres and explosive dust atmospheres shall be separate and not combined; See 29.13 for an alternative system of marking that permits some elements of the markings described in 29.4 or 29.5 to be combined, resulting in a more concise Ex marking.
- g) any additional marking prescribed in the specific standards for the types of protection concerned, as in Clause 1.

NOTE 4 Additional marking may be required by the applicable industrial safety standards for construction of the electrical equipment.

☐ Additionally, the nameplate shall include the following fan details:

- za) rating information (casing pressure and temperature), where applicable;
- zb) where appropriate, maximum inlet temperature;
- zc) for variable speed fans, the speed range. ☐

29.4 Ex marking for explosive gas atmospheres

The Ex marking shall include the following:

- a) the symbol Ex, which indicates that the electrical equipment corresponds to one or more of the types of protection which are the subject of the specific standards listed in Clause 1;
- b) the symbol for each type (or level) of protection used:
- "d": flameproof enclosure, (for EPL Gb or Mb)
 - "e": increased safety, (for EPL Gb or Mb)
 - "ia": intrinsic safety, (for EPL Ga or Ma)
 - "ib": intrinsic safety, (for EPL Gb or Mb)
 - "ic": intrinsic safety, (for EPL Gc)
 - "ma": encapsulation, (for EPL Ga or Ma)
 - "mb": encapsulation, (for EPL Gb or Mb)
 - "mc": encapsulation, (for EPL Gc)
 - "nA": non-sparking, (for EPL Gc)
 - "nC": protected sparking, (for EPL Gc)
 - "nR": restricted breathing, (for EPL Gc)
 - "o": oil immersion, (for EPL Gb)
 - "pv": pressurization, (for EPL Gb or Gc)
 - "px": pressurization, (for EPL Gb or Mb)
 - "py": pressurization, (for EPL Gb)
 - "pz": pressurization, (for EPL Gc)

– "q": powder filling, (for EPL Gb or Mb)

c) the symbol of the group:

- I for electrical equipment for mines susceptible to firedamp;
- IIA, IIB or IIC for electrical equipment for places with an explosive gas atmosphere other than mines susceptible to firedamp.

When the electrical equipment is for use only in a particular gas, the chemical formula or the name of the gas in parentheses.

When the electrical equipment is for use in a particular gas in addition to being suitable for use in a specific group of electrical equipment, the chemical formula shall follow the group and be separated with the symbol "+", for example, "IIB + H₂";

NOTE 1 Equipment marked "IIB" is suitable for applications requiring Group IIA equipment. Similarly, equipment marked "IIC" is suitable for applications requiring Group IIA and Group IIB equipment.

d) for Group II electrical equipment, the symbol indicating the temperature class. Where the manufacturer wishes to specify a maximum surface temperature between two temperature classes, he may do so by marking that maximum surface temperature in degrees Celsius alone, or by marking both that maximum surface temperature in degrees Celsius and, in parentheses, the next highest temperature class, for example, T1 or 350 °C or 350 °C (T1).

Group II electrical equipment, having a maximum surface temperature greater than 450 °C, shall be marked only with the maximum surface temperature in degrees Celsius, for example, 600 °C.

Where the Group II electrical equipment has multiple temperature classes, e.g. for multiple ambient temperature ranges, and it is impractical to include the complete information in the marking, or where there are external sources of heating / cooling (See 5.1.2);

- the complete temperature class information shall be included in the certificate and the marking shall include the symbol "X" to indicate this specific condition of use according to item e) of 29.3, and
- the temperature class range shall be shown in the marking with the lower and upper limits of the temperature class separated by "...", e.g. "T6...T3".

Group II electrical equipment, marked for use in a particular gas, need not have a temperature class or maximum surface temperature marking.

Ex cable glands, Ex blanking elements, and Ex thread adapters need not be marked with a temperature class or maximum surface temperature in degrees Celsius.

e) the equipment protection level, "Ga", "Gb", "Gc", "Ma", or "Mb" as appropriate.

NOTE 2 The EPL marked on the equipment may be more restrictive than that normally applied for a specific type of protection to account for other aspects of the equipment such as material limitations. For example Ex ia IIC T4 Gb, where the equipment was constructed of aluminium in a greater content than permitted by 8.3.

f) Where appropriate according to 5.1.1, the marking shall include either the symbol T_a or T_{amb} together with the range of ambient temperature or the symbol "X" to indicate this specific condition of use according to item e) of 29.3. If the equipment is also marked for use in explosive dust atmospheres and the ambient temperature range rating is identical, only one marking of ambient temperature range need appear.

The markings a) to e) according to 29.4 shall be placed in the order in which they are given in 29.4 and shall each be separated by a small space.

For associated apparatus suitable for installation in a hazardous area, and where the energy limitation is provided inside the equipment in the hazardous area, the symbols for the type of protection shall be enclosed within square brackets, for example, Ex d [ia] IIC T4 Gb. When the equipment group of the associated apparatus differs from that of the equipment, the equipment group of the associated apparatus shall be enclosed within the square brackets, for example, Ex d [ia IIC Ga] IIB T4 Gb.

NOTE 3 A typical example is a shunt diode safety barrier located inside a flameproof enclosure.

For associated apparatus suitable for installation in a hazardous area, and where the energy limitation is provided from outside the equipment in a hazardous area, the symbols for the type of protection shall not be enclosed within square brackets, for example, Ex d ia IIC T4 Gb.

NOTE 4 A typical example is a flameproof luminaire with an intrinsically safe photocell connected to a safe area.

For associated apparatus not suitable for installation in a hazardous area, both the symbol Ex and the symbol for the type of protection shall be enclosed within the same square brackets, for example, [Ex ia] IIC.

For equipment that includes both associated apparatus and intrinsically safe apparatus with no connections required to be made to the intrinsically safe part of the equipment by the user, the "associated apparatus" marking shall not appear unless the equipment protection levels differ. For example, Ex d ib IIC T4 Gb and not Ex d ib [ib Gb] IIC T4 Gb, but Ex d ia [ia Ga] IIC T4 Gb is correct for differing equipment protection levels.

NOTE 5 For associated apparatus not suitable for installation in a hazardous area, a temperature class is not included.

29.5 Ex marking for explosive dust atmospheres

The Ex marking shall include the following:

- a) the symbol Ex, which indicates that the electrical equipment corresponds to one or more of the types of protection which are the subject of the specific standards listed in Clause 1;
- b) the symbol for each type (or level) of protection used:
 - "ta": protection by enclosure, (for EPL Da)
 - "tb": protection by enclosure, (for EPL Db)
 - "tc": protection by enclosure, (for EPL Dc)
 - "ia": intrinsic safety, (for EPL Da)
 - "ib": intrinsic safety, (for EPL Db)
 - "ma": encapsulation, (for EPL Da)
 - "mb": encapsulation, (for EPL Db)
 - "mc": encapsulation, (for EPL Dc)
 - "p": pressurization, (for EPL Db or Dc)
- c) the symbol of the group:
 - IIIA, IIIB or IIIC for electrical equipment for places with an explosive dust atmosphere;
- d) the maximum surface temperature in degrees Celsius and the unit of measurement °C preceded with the letter "T", (e.g. T 90 °C).

Where appropriate according to 5.3.2.3, the maximum surface temperature T_L shall be shown as a temperature value in degrees Celsius and the unit of measurement °C, with the layer depth L indicated as a subscript in mm, (e.g. $T_{500} 320$ °C) or marking shall include the symbol "X" to indicate this condition of use according to item e) of 29.3.

Where the Group III electrical equipment has multiple maximum surface temperatures, e.g. for multiple ambient temperature ranges, and it is impractical to include the complete information in the marking, or where there are external sources of heating / cooling (See 5.1.2);

- the complete maximum surface temperature information shall be included in the certificate and the marking shall include the symbol "X" to indicate this specific condition of use according to item e) of 29.3, and

- the maximum surface temperature range shall be shown in the marking with the lower and upper limits of the surface temperature separated by "...", e.g. "T80 °C...T195 °C".

Ex cable glands, Ex blanking elements, and Ex thread adapters need not be marked with a maximum surface temperature;

- e) the equipment protection level, "Da", "Db", or "Dc", as appropriate;

NOTE 2 The EPL marked on the equipment may be more restrictive than that normally applied to a specific type of protection to account for other aspects of the equipment such as material limitations. For example Ex ia IIIC T135°C **Dc**, where the equipment was constructed of aluminium in a greater content than permitted by 8.4.

- f) where appropriate according to 5.1.1, the marking shall include either the symbol T_a or T_{amb} together with the range of ambient temperature or the symbol "X" to indicate this specific condition of use according to item c) of 29.3. If the equipment is also marked for use in explosive gas atmospheres and the ambient temperature range rating is identical, only one marking of ambient temperature range need appear.

The markings a) to e) according to 29.5 shall be placed in the order in which they are given in 29.5 and shall each be separated by a small space.

For associated apparatus suitable for installation in a hazardous area, and where the energy limitation is provided inside the equipment in the hazardous area, the symbols for the type of protection shall be enclosed within square brackets, for example, Ex tb [ia Da] IIIC T100 °C Db. When the equipment group of the associated apparatus differs from that of the equipment, the equipment group of the associated apparatus shall be enclosed within the square brackets, for example, Ex tb [ia IIIC Da] IIIB T100 °C Db.

NOTE 3 A typical example is a shunt diode safety barrier located inside a dust-protected enclosure.

For associated apparatus suitable for installation in a hazardous area, and where the energy limitation is provided from outside the equipment in a hazardous area, the symbols for the type of protection shall not be enclosed within square brackets, for example, Ex tb ia IIIC T100 °C Db.

NOTE 4 A typical example is a dust-protected luminaire with an intrinsically safe photocell connected to a safe area.

For associated apparatus not suitable for installation in a hazardous area, both the symbol Ex and the symbol for the type of protection shall be enclosed within the same square brackets, for example, [Ex ia Da] IIIC.

For equipment that includes both associated apparatus and intrinsically safe apparatus with no connections required to be made to the intrinsically safe part of the equipment by the user, the associated apparatus marking shall not appear unless the equipment protection levels differ. For example, Ex ib tb IIIC T100 °C Db and not Ex ib tb [ib Db] IIIC T100 °C Db, but Ex ia tb [ia Da] IIIC T100 °C Db is correct for differing equipment protection levels.

NOTE 5 For associated apparatus not suitable for installation in a hazardous area, a temperature marking is not included.

29.6 Combined types (or levels) of protection

Where different types (or levels) of protection are employed for different parts of electrical equipment or an Ex Component, the Ex marking shall include the symbols for all of the types (or levels) of protection employed. The symbols for the types of protection shall appear in alphabetical order, with small separating spaces. When associated apparatus is incorporated, the symbols for the type (or level) of protection, including the square brackets as applicable, shall follow those symbols of the type (or level) of protection for the equipment.

29.7 Multiple types of protection

Equipment may be designed using multiple types of protection so that it is suitable for installation in different ways, using the appropriate installation requirements for the selected

type of protection. For example, equipment which is designed to comply simultaneously with the equipment requirements for Ex i and also with the equipment requirements for Ex de; may be installed, according to the selection of the installer/user.

In this case,

- each respective Ex marking shall be separately indicated on the equipment marking and except in the case of cable glands, blanking elements, and thread adapters, shall be prefixed by a place for an identification marking to allow the stated Ex marking to be identified at the time of installation,
- each respective Ex marking shall be separately indicated on the certificate.

When a single certificate is prepared with each Ex marking shown individually in the certificate, the applicable marking and any variation in the parameters or specification for each of the different Ex markings shall be shown without ambiguity.

When a separate certificate is prepared for each Ex marking, all the relevant parameters or specifications shall be provided in the certificate for the individual Ex marking.

29.8 Ga equipment using two independent Gb types (or levels) of protection

Where two independent types of protection, with EPL Gb, are employed for the same piece of electrical equipment in order to achieve EPL Ga, the Ex marking shall include the symbols for the two types (or levels) of protection employed with the symbols for the types (or levels) of protection joined with a "+". See IEC 60079-26.

29.9 Ex Components

Ex Components, according to Clause 13, shall be legibly marked and the marking shall include the following:

- Ⓒ11 a) the name and address of the manufacturer; Ⓒ11
- b) the manufacturer's type identification;
- c) the symbol Ex;
- d) the symbol for each type (or level) of protection used;
- e) the symbol of the group of the electrical equipment of the Ex Component;
- f) the name or mark of the issuer of the certificate, and the number of the certificate;
- g) the symbol "U"; and

NOTE 1 The symbol "X" is not used.

- h) the additional marking prescribed in the specific standard for the types of protection concerned, as in Clause 1.

NOTE 2 Additional marking may be required by the standards for construction of the electrical equipment.

- i) As much of the remaining marking information per 29.4 or 29.5, as applicable, as can be accommodated.

The Ex marking for explosive gas atmospheres and explosive dust atmospheres shall be separate and not combined.

29.10 Small equipment and small Ex Components

On small electrical equipment and on Ex Components where there is limited space, a reduction in the marking is permitted. The following lists the minimum marking that is required on the equipment or Ex Component:

- Ⓒ11 a) the name and address of the manufacturer; Ⓒ11

- b) the manufacturer's type identification. The type identification is permitted to be abbreviated or omitted if the certificate reference allows identification of the specific type;
- c) the name or mark of the issuer of the certificate, and the number of the certificate; and
- d) the symbol "X" or "U" (if appropriate);

NOTE The symbols "X" and "U" are never used together.

- e) As much of the remaining marking information per 29.4 or 29.5, as applicable, as can be accommodated.

29.11 Extremely small equipment and extremely small Ex Components

In the case of extremely small electrical equipment and extremely small Ex Components where there is no practical space for marking, a marking intended to be linked to the equipment or Ex Component is permitted. This marking shall be identical to the marking of 29.3, 29.4, and 29.5, as applicable, shall appear on a label provided with the equipment or Ex Component for field installation adjacent to the equipment or Ex Component.

29.12 Warning markings

Where any of the following warning markings are required on the equipment, the text as described in Table 16, following the word "WARNING," may be replaced by technically equivalent text. Multiple warnings may be combined into one equivalent warning.

Table 16 – Text of warning markings

	Reference	WARNING marking
a)	6.3	WARNING – AFTER DE-ENERGIZING, DELAY <i>Y</i> MINUTES BEFORE OPENING (<i>Y</i> being the value in minutes of the delay required)
b)	6.3, 23.12	WARNING – DO NOT OPEN WHEN AN EXPLOSIVE ATMOSPHERE IS PRESENT
c)	18.2	WARNING – DO NOT OPERATE UNDER LOAD
d)	18.4 b), 19 21.2 b, 21.3 b)	WARNING – DO NOT OPEN WHEN ENERGIZED
e)	20.1 b)	WARNING – DO NOT SEPARATE WHEN ENERGIZED
f)	20.1 b)	WARNING – SEPARATE ONLY IN A NON-HAZARDOUS AREA
g)	7.4.2 g)	WARNING – POTENTIAL ELECTROSTATIC CHARGING HAZARD – SEE INSTRUCTIONS
h)	18.4 2) 21.2 2 21.3.2)	WARNING – LIVE PARTS BEHIND COVER – DO NOT CONTACT

29.13 Alternate marking of equipment protection levels (EPLs)

The marking of the equipment protection levels is shown by the use of an upper case letter for the specific explosive atmosphere for which the equipment is suitable and a lower case letter indicating the level. As an alternate to the marking given in 29.4 and 29.5 the 'M', 'G' and 'D' are not used as the specific explosive atmosphere is recognised by the marking of the equipment groups 'I' (mining), 'II' (gases and vapours) and 'III' (combustible dusts) and the lower case letter for the level is added to the type of protection where it does not already exist.

The alternate marking of equipment Protection Levels (EPLs) is not permitted when IEC 60079-26 is applied for equipment intended for installation in the boundary wall between an area requiring EPL Ga and a less hazardous area. See the "Marking" clause of IEC 60079-26.

The alternate marking of equipment Protection Levels (EPLs) is not permitted when a more restrictive EPL than that normally applied for a specific type of protection is required to account for other aspects of the equipment such as material limitations. See 29.4 e) or 29.5 e).

29.13.1 Alternate marking of type of protection for explosive gas atmospheres

As an alternate to marking of the type of protection in 29.4 b) the following symbols shall include the level, resulting in a Level of Protection as:

- "db": flameproof enclosure.
- "eb": increased safety.
- "ia": intrinsic safety.
- "ib": intrinsic safety.
- "ic": intrinsic safety.
- "ma": encapsulation.
- "mb": encapsulation.
- "mc": encapsulation.
- "nAc": non-sparking.
- "nCc": protected sparking.
- "nRc": restricted breathing.
- "ob": oil immersion.
- "pvc": pressurization.
- "pxb": pressurization.
- "pyb": pressurization.
- "pzc": pressurization.
- "qb": powder filling.

29.13.2 Alternate marking of type of protection for explosive dust atmospheres

As an alternate to marking of the type of protection in 29.5 b) the following symbols shall include the level as:

- "ta": protection by enclosure.
- "tb": protection by enclosure.
- "tc": protection by enclosure.
- "ia": intrinsic safety.
- "ib": intrinsic safety.
- "ma": encapsulation.
- "mb": encapsulation.
- "mc": encapsulation.
- "pb": pressurization.
- "pc": pressurization.

29.14 Cells and batteries

In accordance with 23.11, where it is necessary for the user to replace cells or batteries contained within an enclosure, the relevant parameters to allow correct replacement shall be legibly and durably marked on or inside the enclosure. Either the manufacturer's name and part number, or the electrochemical system, nominal voltage and rated capacity shall be included.

gas atmospheres other than mines susceptible to firedamp, with gas of ignition temperature greater than 125 °C and with specific conditions of use indicated in the certificate.

H. ATHERINGTON Ltd
TYPE 250 JG 1

Ex e px IIC 125 °C (T4) Gb

alternate Ex eb pxb IIC 125 °C (T4)

No. 56732

GHI 02.0076 X

.....
.....

Electrical equipment, utilizing types of protection flameproof enclosure "d" (EPL Mb and Gb) and increased safety "e" (EPL Mb and Gb) for use in mines susceptible to firedamp and explosive gas atmospheres other than mines susceptible to firedamp with gas of subdivision B and ignition temperature greater than 200 °C.

A.R. ACHUTZ A.G.

TYPE 5 CD

Ex d e I Mb

alternate Ex db eb I

Ex d e IIB T3 Gb

alternate Ex db eb IIB T3

No. 5634

JKL 02.0521

.....
.....

Electrical equipment, utilizing type of protection increased safety "e" (EPL Gb) for use in explosive gas atmospheres other than mines susceptible to firedamp with gas of subdivision C and ignition temperature greater than 85 °C.

GS & Co A.G.

Ex e IIC T6 Gb

alternate Ex eb IIC T6

No. 1847

HYD 04.0947

.....
.....

Electrical equipment with type of protection flameproof enclosure "d" (EPL Gb) for explosive gas atmospheres other than mines susceptible to firedamp on the basis of ammonia gas only.

WOKAITERT SARL

TYPE NT 3

Ex d II (NH₃) Gb

alternate Ex db II (NH₃)

No. 6549

MNO 02.3102

.....
.....

Electrical equipment with type of protection encapsulation "ma" (EPL Da) for explosive dust atmospheres containing conductive dusts of Group IIIC with a maximum surface temperature of less than 120 °C.

ABC company

Type RST

Serial No. 123456

Ex ma IIIC T120 °C Da

alternate Ex ma IIIC T120 °C

N.A. 01.9999

.....
.....

Electrical equipment with type of protection "ia" (EPL Da) for explosive dust atmospheres containing conductive dusts of Group IIIC with a maximum surface temperature of less than 120 °C.

<http://www.china-gauges.com/>

ABC company
Type XYZ
Serial No. 123456
Ex ia IIIC T120 °C Da
N.A. 01.9999

alternate Ex ia IIIC T120 °C

.....
.....

Electrical equipment with type of protection "p" (EPL Db) for explosive dust atmospheres containing conductive dusts of Group IIIC with a maximum surface temperature of less than 120 °C.

ABC company
Type KLM
Serial No. 123456
Ex p IIIC T120 °C Db
N.A. 01.9999

alternate Ex pb IIIC T120 °C

.....
.....

Electrical equipment with type of protection "t" (EPL Db) for explosive dust atmospheres containing conductive dusts of Group IIIC with a maximum surface temperature of less than 225 °C and less than 320 °C when tested with a 500 mm dust layer.

ABC company
Type RST
Serial No. 987654
Ex tb IIIC T225 °C T₅₀₀ 320 °C Db
N.A. 02.1111

alternate Ex tb IIIC T225 °C T₅₀₀ 320 °C

.....
.....

Electrical equipment with type of protection "t" (EPL Db) for explosive dust atmospheres containing conductive dusts of Group IIIC with a maximum surface temperature of less than 175 °C with an extended ambient temperature range of -40 °C to +120 °C.

ABC company
Type RST
Serial No. 987654
Ex tb IIIC T175 °C Db
-40 °C ≤ T_{amb} ≤ 120 °C
N.A. 02.1111

alternate Ex tb IIIC T175 °C

.....
.....

Electrical equipment with type of protection encapsulation "ma" (EPL Ga) for explosive gas atmospheres of Group IIC with a maximum surface temperature of less than 135 °C and with type of protection encapsulation "ma" (EPL Da) for explosive dust atmospheres containing conductive dusts of Group IIIC with a maximum surface temperature of less than 120 °C. A single certificate has been prepared.

ABC company
Type RST
Serial No. 123456
Ex ma IIC T4 Ga
Ex ma IIIC T120 °C Da
N.A. 01.9999

alternate Ex ma IIC T4
alternate Ex ma IIIC T120 °C

.....
.....

Electrical equipment with type of protection encapsulation "ma" (EPL Ga) for explosive gas atmospheres of Group IIC with a maximum surface temperature of less than 135 °C and with type of protection encapsulation "ma" (EPL Da) for explosive dust atmospheres containing conductive dusts of Group IIIC with a maximum surface temperature of less than 120 °C. Two independent Certificates have been prepared.

ABC company
Type RST
Serial No. 123456
Ex ma IIC T4 Ga
N.A. 01.1111

alternate Ex ma IIC T4

Ex ma IIIC T120 °C Da
N.B. 01.9999

alternate Ex ma IIIC T120 °C

.....
.....

[C11] NOTE The examples only show the name of the manufacturer and not the address of the manufacturer and are therefore incomplete according to clauses 29.3 a), 29.9 a), 29.10 a). **[C11]**

30 Instructions

30.1 General

The documentation prepared as required by Clause 24 shall include instructions, providing the following particulars as a minimum:

- a recapitulation of the information with which the electrical equipment is marked, except for the serial number (see Clause 29), together with any appropriate additional information to facilitate maintenance (for example, address of the importer, repairer, etc.);
- instructions for safety, i.e.
 - putting into service;
 - use;
 - assembling and dismantling;
 - maintenance, overhaul and repair;
 - installation;
 - adjustment;
- where necessary, training instructions;
- details which allow a decision to be made as to whether the equipment can be used safely in the intended area under the expected operating conditions;
- electrical and pressure parameters, maximum surface temperatures and other limit values;
- where applicable, specific conditions of use according to 29.3 e);
- where applicable, any special conditions of use, including particulars of possible misuse which experience has shown might occur;
- where necessary, the essential characteristics of tools which may be fitted to the equipment;
- a list of the standards, including the issue date, with which the equipment is declared to comply. The certificate prepared in accordance with 28.2 can be used to satisfy this requirement.

30.2 Cells and batteries

In accordance with 23.11, where it is necessary for the user to replace cells or batteries contained within an enclosure, the relevant parameters to allow correct replacement shall be included in the instructions, including either the manufacturer's name and part number, or the electrochemical system, nominal voltage and rated capacity. When replacement of the batteries or cells is intended to be done only when an explosive atmosphere is not present, the instructions shall specify the procedure for battery or cell replacement.

In accordance with 23.12, where it is necessary for the user to replace a battery pack, the instructions shall include the relevant parameters to allow correct replacement per 29.14. When replacement of the battery pack is intended to be done only when an explosive

<http://www.china-gauges.com/>

atmosphere is not present, the instructions shall specify the procedure for battery pack replacement.

30.3 Electrical machines

In addition to the information required according to 30.1, the following additional information shall be prepared for electrical machines:

- Speed/torque curves for machines intended to be supplied by a converter
- Guidance for the selection and installation of any necessary overload or over-temperature protection of the motor. This may be in addition to that protection provided by a converter.
- Lubrication requirements for both commissioning and maintaining.

30.4 Ventilating fans

☐ For Group I equipment, the applicable requirements of EN 1710 shall be applied.

For Group II and Group III equipment, all requirements of EN 14986 shall be applied. ☐

Annex A (normative)

Supplementary requirements for cable glands

A.1 General

This annex specifies the additional requirements for the construction, testing and marking of cable glands and may be further supplemented or modified by the standards listed in Clause 1.

NOTE 1 The minimum diameter of cable for which the entry is suitable is specified by the manufacturer. The user should ensure that, taking tolerances into account, the minimum dimensions of the cable selected for use in the cable gland are equal to, or exceed, the specified values.

The requirements of Annex A apply also to cable transit devices which may be certified as either equipment or as an Ex Component. The cable transit device may only be certified as equipment provided that the device includes a flange gasket and the manufacturer's instructions state that the device shall be mounted in such a way that the joints between the flange and the enclosure fulfils the required degree of ingress protection after mounting. The particular gasket shall be included as part of the tests of A.3.4. The device certificate number shall include the suffix "X" to indicate this specific condition of use according to item e) of 29.3 and this specific condition of use regarding ingress protection (IP) after mounting, shall be stated on the certificate.

NOTE 2 Depending on the form of construction and the resilience of the gasket, the condition or instructions may need to refer to the flatness or rigidity of the enclosure to which the gland may be attached.

A.2 Constructional requirements

A.2.1 Cable sealing

The cable sealing between the cable and the gland body shall be ensured by one of the following means (see Figure A.1):

- an elastomer sealing ring;
- a metallic or composite sealing ring;
- a filling compound.

The cable sealing may be made of a single material or a combination of materials and shall be appropriate to the shape of the cable concerned.

NOTE 1 In selecting the materials for metallic or composite sealing rings, attention is drawn to Note 4 of 6.1.

NOTE 2 The type of protection of the enclosure may also depend on the internal construction of the cable.

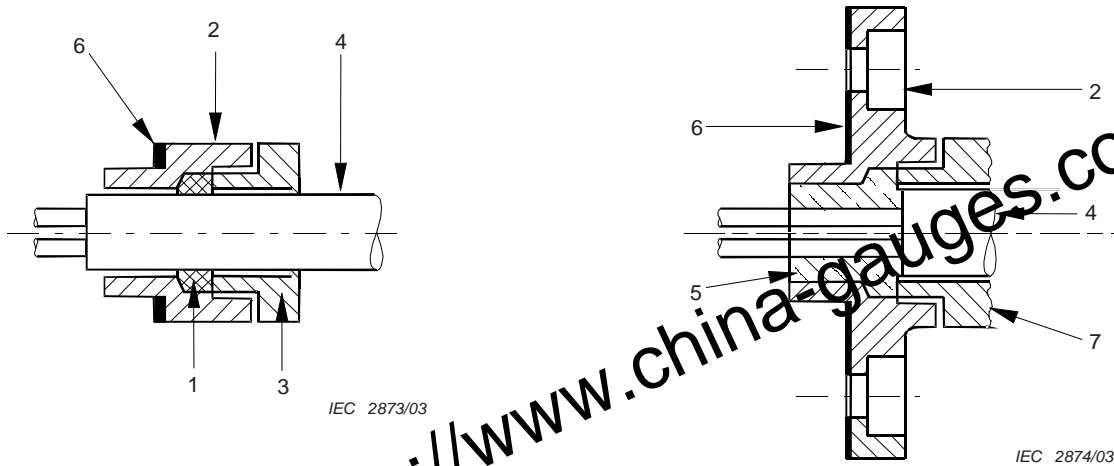

Components

- 1 sealing ring
- 2 gland body
- 3 compression element

- 4 cable
- 5 filling compound
- 6 gasket (where required)
- 7 compound retaining element

Figure A.1 – Illustration of the terms used for cable glands

A.2.2 Filling compounds

Materials used as filling compounds shall comply with the requirements of Clause 12 for materials used for cementing.

A.2.3 Clamping

A.2.3.1 General

Cable glands shall provide clamping of the cable in order to prevent pulling or twisting applied to it from being transmitted to the connections. Such clamping can be provided by a clamping device, sealing ring or filling compound. Whichever clamping arrangement is used, it shall be capable of meeting the relevant type tests in Clause A.3.

A.2.3.2 Group II or III cable glands

Cable glands for Group II or III equipment, without a clamping device, shall also be accepted as complying with this annex if they are capable of passing the clamping tests with values reduced to 25 % of those required in Clause A.3. The descriptive documents shall then state that such cable glands may not provide sufficient clamping and that the user shall provide additional clamping of the cable to ensure that pulling and twisting is not transmitted to the terminations. Such cable glands shall be marked with the symbol “X” to indicate this specific condition of use according to item e) of 29.3.

A.2.4 Lead-in of cable

A.2.4.1 Sharp edges

Cable glands shall not have sharp edges capable of damaging the cable.

A.2.4.2 Point of entry

In the case of flexible cables, the point of entry shall include a rounded edge at an angle of at least 75°, the radius R of which is at least equal to one-quarter of the diameter of the maximum admissible cable in the entry but which need not exceed 3 mm (see Figure A.2).

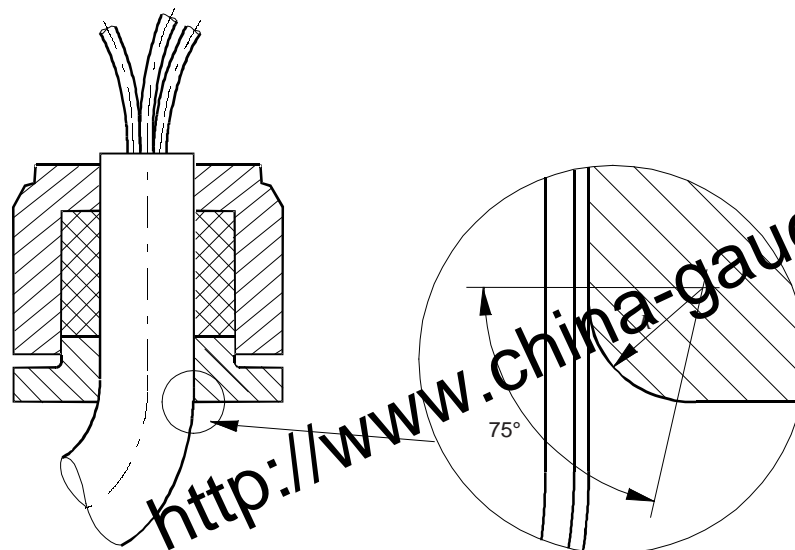

Figure A.2 – Rounded edge of the point of entry of the flexible cable

A.2.5 Release by a tool

Cable glands shall be designed so that after installation they are only capable of being released or dismantled by means of a tool.

A.2.6 Fixing

The means of fixing cable glands to enclosures of electrical equipment shall be capable of retaining the cable gland when subjected to the mechanical tests of clamping and resistance to impact in Clause A.3.

A.2.7 Degree of protection

Cable glands, when installed in accordance with the instructions required by Clause 30, shall be capable of providing, with the enclosure on which they are fixed, the same degree of protection as required for the enclosure.

Cable glands marked with a degree of protection (IP) shall be tested in accordance with A.3.4.

A.3 Type tests

A.3.1 Tests of clamping of non-armoured and braided cables

A.3.1.1 Cable glands with clamping by the sealing ring

The tests of clamping shall be carried out using for each type and size of cable gland, two sealing rings; one equal to the smallest admissible size and the other equal to the largest admissible size.

For elastomer sealing rings for circular cables, each ring shall be mounted on a clean, dry, polished, cylindrical, steel or stainless steel mandrel, with a maximum surface roughness of $1,6 \mu\text{m}$, R_a , equal to the smallest cable diameter allowable in the ring and specified by the manufacturer of the cable gland.

For non-circular cables, the ring for each type/size/shape of cable shall be mounted on a sample of dry, clean cable of dimensions equal to the size specified by the manufacturer of

the cable gland. Such cable glands shall be marked with the symbol “X” to indicate this specific condition of use according to item e) of 29.3.

For metallic-sheathed cables, the ring for each size of cable shall be mounted on a sample of dry, clean cable constructed with the sheath material and with dimensions equal to the size as specified by the manufacturer of the cable gland. Such cable glands shall be marked with the symbol “X” to indicate this specific condition of use according to item e) of 29.3.

For metallic sealing rings, each ring shall be mounted on a clean, dry, polished, cylindrical, metal mandrel, with a maximum surface roughness of 1.6 μm Ra, equal to the smallest cable diameter allowable in the ring and specified by the manufacturer of the cable gland.

The sealing ring with the mandrel or the cable, as appropriate, shall be fitted into the cable gland. A torque shall then be applied to the screws (in the case of a flanged compression element fitted with screws) or to the nut (in the case of a screwed compression element) to compress the sealing ring to prevent slipping of the mandrel or cable.

The complete cable gland and mandrel assembly shall then be subjected to the thermal endurance tests, if applicable. The maximum service temperature shall be considered to be 75 °C unless otherwise specified by the manufacturer.

NOTE 1 The 75 °C service temperature is the median of the branching point and entry point temperatures.

NOTE 2 Cable glands employing only metallic sealing rings and metallic parts do not require thermal endurance tests.

The sealing ring shall prevent slippage of the cable or mandrel when the force applied to the cable or mandrel, in Newtons, is equal to

- 20 times the value in millimetres of the diameter of the mandrel or cable when the cable gland is designed for round cable, or
- 6 times the value in millimetres of the perimeter of the cable when the cable gland is designed for non-circular cable.

Where the direction of pull is other than horizontal, the means of application of the force shall be adjusted to compensate for the weight of the mandrel and associated parts.

For cable glands intended for use with braided cables, this clamping test is intended to demonstrate the effectiveness of the cable gland in clamping the cable, not the strength of the braid. Where the test is performed with braided cable, the braid shall not be clamped.

The test conditions and acceptance criteria are given in A.3.1.4.

NOTE 3 The torque figures referred to above may be determined experimentally prior to the tests or they may be supplied by the manufacturer of the cable gland.

A.3.1.2 Cable glands with clamping by filling compound

The tests of clamping shall be carried out for each type and size of cable glands using two samples of clean, dry cable or metal mandrels if applicable; one equal to the smallest admissible size and the other equal to the largest admissible size.

The available space shall be filled with the filling compound, which has been prepared and hardened in accordance with the manufacturer of the cable gland's instructions prior to being submitted to the tests.

The complete cable gland and mandrel assembly shall then be subjected to the thermal endurance tests. The maximum service temperature shall be considered to be 75 °C unless otherwise specified by the manufacturer.

NOTE The 75 °C service temperature is the median of the branching point and entry point temperatures.

The filling compound shall prevent slippage of the cable when the force applied, in Newtons, is equal to

- 20 times the value in millimetres of the diameter of the cable sample when the cable gland is designed for circular cable, or
- 6 times the value in millimetres of the perimeter of the cable sample when the cable gland is designed for non-circular cable.

For cable glands intended for use with braided cables, the clamping test is intended to demonstrate the effectiveness of the cable gland in clamping the cable, not the strength of the braid. Where the design of the cable gland is such that the braid is intended to be surrounded by compound, the contact of the compound with the braid shall be minimized for this test.

The test conditions and acceptance criteria are given in A.3.1.4.

A.3.1.3 Cable glands with clamping by means of a clamping device

The clamping test shall be carried out on each type and size of cable gland for the different allowable sizes of each type of cable gland clamping device.

Each device shall be mounted on a steel or stainless steel mandrel or on a sample of clean, dry cable of a size allowable in the device as specified by the manufacturer of the cable gland.

The clamping device with any required sealing ring and the largest size of cable allowable in that clamping device, as specified by the manufacturer of the cable gland, shall be fitted in the cable gland. The gland shall be assembled with compression of any required sealing ring and tightening of the clamping device. The test procedure shall be carried out in accordance with A.3.1.1 and then repeated with the smallest size of mandrel or cable allowable in that clamping device, as specified by the manufacturer of the cable gland.

For cable glands intended for use with braided cables, this clamping test is intended to demonstrate the effectiveness of the cable gland in clamping the cable, not the strength of the braid. Where the test is performed with braided cable, the braid shall not be clamped.

A.3.1.4 Tensile test

The test sample, as prepared in A.3.1.1 to A.3.1.3, as appropriate, shall be subjected to a constant tensile force equal to that given in A.3.1.1 or A.3.1.2, as appropriate. The load shall be applied for not less than 6 h. The test shall be carried out at an ambient temperature of (20 ± 5) °C. The clamping assured by the sealing ring, filling compound or by the clamping device shall be acceptable if the slippage of the mandrel or cable sample is not more than 6 mm.

A.3.1.5 Mechanical strength

After the tensile tests have been completed, the cable gland shall be submitted to the tests and examinations of a) to c) as appropriate.

- a) For cable glands with clamping by sealing ring or a clamping device, a mechanical strength test on which a torque of at least 1,5 times the value needed to prevent slipping shall be applied to the screws or nuts (whichever is the case). The cable gland shall then be dismantled and the components examined. The mechanical strength of the cable gland shall be acceptable if no deformation affecting the type of protection is found. Any deformation of the sealing rings shall be ignored.
- b) For cable glands manufactured from non-metallic materials, it is possible that the prescribed proof torque cannot be met due to temporary deformations of the thread. If no

noticeable damage is found, the cable gland shall be deemed to have passed the test if the tensile test of A.3.1.4 can still be achieved without adjustment.

- c) For cable glands with clamping by filling compound, the gland shall be dismantled as far as possible without damaging the filling compound. Upon examination, there shall be no physical or visible damage to the filling compound that would affect the type of protection afforded.

A.3.2 Tests of clamping of armoured cables

A.3.2.1 Tests of clamping where the armourings are clamped by a device within the gland

The tests shall be carried out using a sample of armoured cable of the smallest size specified for each type and size of gland. The sample of armoured cable shall be fitted into the clamping device of the cable gland. A torque shall then be applied to the screws (in the case of a flanged clamping device) or to the nut (in the case of a screwed clamping device) in order to compress the clamping device and prevent slipping of the armour. The torque so determined shall be used as a reference torque.

The clamping device shall prevent slippage of the armour when the force applied to the armour, in Newtons, is equal to:

- 80 times the value in millimetres of the diameter of the cable over the armour for Group I equipment, or
- 20 times the value in millimetres of the diameter of the cable over the armour for Group II or III equipment.

NOTE 1 The torque values referred to above may be determined experimentally prior to the tests, or they may be supplied by the manufacturer of the cable gland.

The complete cable gland and armoured cable shall then be subjected to the thermal endurance tests. The maximum service temperature shall be considered to be 75 °C unless otherwise specified by the manufacturer.

NOTE 2 The 75 °C service temperature is the median of the branching point and entry point temperatures.

NOTE 3 Cable glands employing only metallic sealing rings and metallic parts do not require thermal endurance tests.

A.3.2.1.1 Tensile test

The test sample shall be subjected to a constant tensile force equal to that defined in A.3.2.1 shall be applied for (120 ± 10) s. The test shall be carried out at an ambient temperature of (20 ± 5) °C. The clamping assured by the clamping device shall be acceptable if the slipping of the armour is effectively negligible.

A.3.2.1.2 Mechanical strength

Where screws and nuts are fitted they shall be tightened to at least 1,5 times the reference torque values established in A.3.2.1.1 and then the cable gland dismantled. The mechanical strength shall be acceptable if no deformation affecting the type of protection is found.

A.3.2.2 Tests of clamping where the armourings are not clamped by a device within the gland

The cable gland shall be treated as if it were a non-armoured type according to A.3.1.

A.3.3 Type test for resistance to impact

For the tests of 26.4.2, the cable gland shall be tested with the smallest specified cable fitted.

For testing purposes, the cable gland shall be fixed on a rigidly mounted steel plate or secured as specified by the manufacturer of the cable gland. The torque applied in fixing a threaded cable gland shall be that used to assemble the samples for the tensile test in A.3.1.4 or A.3.2.1.1, as applicable.

A.3.4 Test for degree of protection (IP) of cable glands

The test shall be carried out in accordance with IEC 60529 as below, using the cable-sealing ring of each of the different permitted sizes for each type of cable gland.

Group I – IP54 Minimum

Group II – IP54 minimum

Group III, EPL Da – IP6X minimum

Group III, EPL Db – IP6X minimum

Group IIIC, EPL Dc – IP6X minimum

Group IIIA or IIIB, EPL Dc – IP5X minimum

For sealing tests, each sealing ring shall be mounted on a sample of clean, dry cable; or a clean, dry, polished, metal mandrel, with a maximum surface roughness of $1,6 \mu\text{m Ra}$, of a diameter equal to the smallest diameter allowable in the ring as specified by the manufacturer of the cable gland. For the purposes of this test, the cable gland with cable or mandrel shall be tested after being fixed to a suitable enclosure ensuring that the sealing method at the interface between the gland and enclosure does not compromise the test results. Prior to the required IP tests, the test samples shall be subjected to the thermal endurance tests (26.8 and 26.9) and resistance to impact (26.4.2) tests.

NOTE These test samples need not be the same test samples subjected to the tensile tests A.3.1.4 and mechanical strength tests A.3.1.5.

A.4 Marking

A.4.1 Marking of cable glands

Cable glands shall be marked in accordance with 29.3 and, unless specified otherwise by the manufacturer, shall including the marking for type of protection “e” in addition to the marking for any other relevant type of protection; and, if a threaded entry, with the type and size of thread.

NOTE 1 The additional requirements for cable glands of type of protection “d” are found in IEC 60079-1.

NOTE 2 The additional requirements for cable glands of type of protection “t” are found in IEC 60079-31.

NOTE 3 The minimum IP requirements vary by equipment Group. See A.3.4

Where marking space is limited, the reduced marking requirements of 29.10 may be applied.

A.4.2 Marking of cable-sealing rings

The cable-sealing rings for cable glands that allow a variety of ring sizes shall be marked with the minimum and maximum diameters, in millimetres, of the permitted cables.

When the cable-sealing ring is bound with a metal washer, the marking may be made on the washer.

The cable-sealing rings shall be identified allowing the user to determine if the ring is appropriate for the cable gland.

Where the gland and the ring are intended to be used at service temperatures outside the range $-20 \text{ }^{\circ}\text{C}$ to $+80 \text{ }^{\circ}\text{C}$, they shall be marked with the temperature range.

Annex B
(normative)

Requirements for Ex Components

Ex Components shall comply with the requirements of the clauses listed in Table B.1.

Table B.1 – Clauses with which Ex Components shall comply

Clause or subclause	Applies (yes or no)	Remarks
1 to 4 (inclusive)	Yes	
5	No	Except that the service temperature limits shall be specified
6.1	Yes	
6.2	No	
6.3	No	
6.4	No	
6.5	Yes	
6.6	Yes	
7.1	Yes	See Note 1
7.2	Yes	See Note 1
7.3	Yes	If external (see Note 1)
7.4	Yes	If external (see Note 1)
7.5	Yes	If external (see Note 1)
8	Yes	
9.1	Yes	
9.2	Yes	But only if it is an equipment enclosure
9.3	Yes	But only if it is an equipment enclosure
10	Yes	
11	Yes	
12	Yes	
13	Yes	
14	Yes	
15.1.1	Yes	But only if it is an equipment enclosure
15.1.2	Yes	But only if it is an equipment enclosure
15.2	Yes	
15.3	Yes	
0	Yes	
15.5	Yes	
16	Yes	But only if it is an equipment enclosure
17	No	Except for machine enclosures
17.2	Yes	
19	Yes	
20	Yes	
21	Yes	
22.1	Yes	
22.2	No	
23	Yes	

Table B.1 (continued)

Clause or subclause	Applies (yes or no)	Remarks
24	Yes	
25	Yes	
26.1	Yes	
26.2	No	
26.3	Yes	
26.4	Yes	But only if it is an equipment enclosure
26.5	Yes	But only if it is an equipment enclosure
26.5.1	Yes	Where necessary to define a service temperature
26.5.2	Yes	Where the maximum temperature is specified
26.5.3	Yes	Where the "small component" relaxation has been employed
26.6	Yes	
26.7	Yes	Where the maximum temperature is specified
26.8	Yes	
26.9	Yes	
26.10	Yes	But only if it is an equipment enclosure
26.11	Yes	But only if it is a Group I equipment enclosure
26.12	Yes	But only if it is an equipment enclosure
26.13	Yes	But only if it is an equipment enclosure
26.14	Yes	But only if it is an equipment enclosure
26.15	Yes	But only if it is an equipment enclosure
26.16	Yes	But only if it is an equipment enclosure
27	Yes	
28	Yes	
29.2	Yes	Marking is required on the Ex Component
29.3	No	
29.4	Yes	See Note 2
29.5	Yes	See Note 2
29.6	Yes	
29.7	Yes	
29.8	Yes	
29.9	Yes	
29.10	Yes	
29.11	Yes	
29.12	No	
29.13	Yes	
29.14	Yes	
29.16	No	
30	Yes	

NOTE 1 It is necessary to consider the circumstances in which these requirements apply to components placed in other enclosures.

NOTE 2 The temperature classification is not applied to Ex Components.

Annex C
(informative)

Example of rig for resistance to impact test

See Figure C.1 for an example of a rig for resistance to impact test.

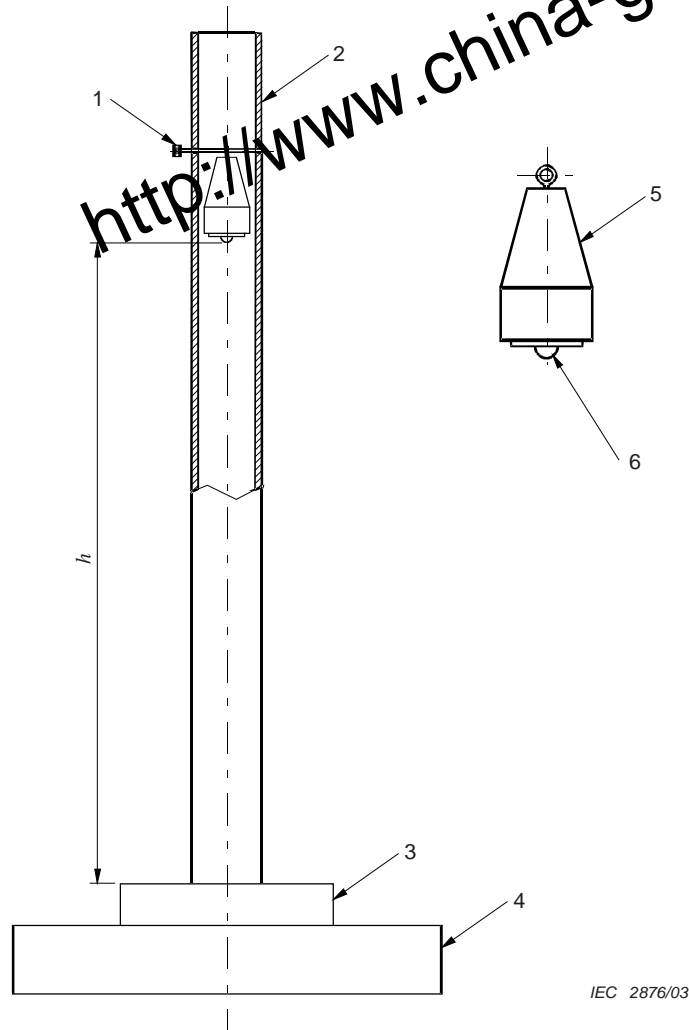

Components

- | | |
|----------------------------------|--|
| 1 adjustment pin | 5 steel mass of 1 kg |
| 2 plastic guide tube | 6 impact head of hardened steel, 25 mm in diameter |
| 3 test piece | h height of fall |
| 4 steel base (mass ≥ 20 kg) | |

Figure C.1 – Example of rig for resistance to impact test

Annex D (informative)

Motors supplied by converters

When motors are supplied from a converter to enable operation at varying speeds and loads, it is necessary to establish the thermal performance with the particular converter (and output filter, if used) throughout the specified speed and torque range. This needs to be done through a combination of type testing and calculation. The specific methods to be used are described in the specific standards for the type of protection.

NOTE 1 Because of possible difficulties in arranging a test with the exact motor/converter combination, tests using a similar converter may be acceptable subject to comparison of the characteristics.

NOTE 2 Additional factors may also need to be taken into account, in discussion between manufacturer, user and installer. These include the provision by the user of additional output filters, or reactors, and the length of cable between converter and motor, which both affect motor input voltage and can cause additional motor heating.

For some types of protection, it will usually be necessary to use a protective device. This device needs to be specified in the documentation and its effectiveness needs to be proven by test or by calculation.

NOTE 3 High-frequency switching in converters can lead to rapid rise time voltage stress in the windings and cable circuits and therefore a further potential source of ignition. It is necessary to consider the effects of this stress according to the type of protection. In some circumstances, it will be necessary to add an additional output filter after the converter.

The descriptive documentation for the motor needs to include the necessary parameters and conditions required for use with a converter.

Stray currents may be introduced into shafts and bearings in motors operated from converters. One or more of the following solutions should be employed:

- Use of suitable output filters
- Use of shaft earthing brushes with a type of protection suitable for the intended EPL
- Use of bearing insulation techniques
- Bonding and earthing cabling and potential equalizing systems
- Suitable converter topology matched with the motor design to minimize common mode voltages.

Alternative methods may be employed which can demonstrate the elimination of common mode voltages.

NOTE 4 Further information is given in IEC/TS 60034-17, IEC 60034-25, and IEEE/PCIC-2002-08.

NOTE 5 These stray currents may also be introduced into other parts of the mechanical system driven by the motor. Similar protection may be required there also.

NOTE 6 The electro-magnetic radiation from cables of converter-fed motors may be sufficient to cause interference with proper operation of Group I pilot wire circuits.

Annex E (informative)

Temperature rise testing of electric machines

Whether the maximum positive tolerance or maximum negative tolerance of the rated voltage will result in the maximum surface temperature, typically depends on the following conditions:

- Small asynchronous machines rated at less than 5 kW, generally exhibit the maximum surface temperature when operating with an applied voltage that is greater than the rated voltage, due to the core loss and magnetizing current, which increases rapidly as the iron core saturates at the higher applied voltage.
- Asynchronous machines rated between 5 kW and 20 kW are influenced by many factors that determine the performance and it is not possible to predict the overriding effect without detailed knowledge of the particular design.
- Larger asynchronous machines rated at more than 20 kW, generally exhibit the maximum surface temperature when operating with an applied voltage that is less than the rated voltage, due to the increased I^2R losses resulting from the increased currents. In this case, these losses are generally greater than those that would occur from core losses and magnetizing current resulting from an applied voltage that is greater than the rated voltage.

NOTE 1 The rated powers shown are general reference values, depending on the relative core magnetizing. High pole machines or specific customization can influence the value.

The alternative temperature determination methods detailed in IEC 60034-29 may be applied. The “±5 %” or “±10 %” supply voltage factors of 26.5.1 should be included in the determination of maximum surface temperature when the methods of IEC 60034-29 are applied.

The maximum surface temperature rise of converter-fed machines should be determined under “worst case” conditions using one of the test methods below:

- Specific converter
 - A machine should be tested with the intended converter.
- Comparable converter
 - A machine may be tested using a comparable converter when sufficient information is available to judge the comparability. Additional safety factors may be applied to account for the degree of comparability.
- Sinusoidal supply
 - The machine torque should be proportional to the square of the speed.
 - The motor should be loaded to maximum load at rated speed.
 - The alternative temperature determination methods detailed in IEC 60034-29 may also be applied.
 - Additional safety factors may be applied to account for the degree of comparability.
- Motors of type of protection “d”, “p2”, or “t” tested on sinusoidal supply
 - Provision of appropriate direct thermal protection, normally in the stator winding, which has sufficient margin to be able to detect and prevent excessive temperatures at the rotor bearings, bearing caps, and shaft extensions. The margin may be determined by test or by calculation. The mandatory use of the thermal protection is shown as a specific condition of use.

² Type of protection “px” may require a mandatory “cool down” time to allow hot internal components to cool to the marked temperature class.

NOTE 2 When agreeable to the manufacturer, the user, and the certification body (if one is involved), calculations, with appropriate safety factors may be used to determine the maximum surface temperature. The calculation should be based on previously established representative test data and in accordance to IEC 60034-7 and IEC 60034-25.

For the determination of the maximum surface temperature, the “worst case” condition of the converter-fed motor needs to be determined, and might include the following:

- Torque/speed characteristics (Variable (square law) / linear / constant torque vs. speed)
 - Motors for Variable torque loads require maximum surface temperature determination at maximum power at maximum rated speed
 - Motors for linear loads and constant torque loads require maximum surface temperature determination at least at the minimum and maximum speed
 - Motors for complex loads require maximum surface temperature determination at least at the break points in the speed/torque curve
- Constant power
 - Require determination maximum surface temperature at minimum and maximum speed
- Voltage drop (cable length, filters, converter)
 - The voltage drop of all components have to be taken into account during project planning and commissioning. Therefore, information about the voltage drop of converter, filter, voltage drop along the cable, system configuration and input voltage for converter will need to be known. The manufacturer’s instructions should provide all relevant information necessary to calculate / set up the range of safe operation.
- Output characteristics of power supply (dV/dt , switching frequency)
 - Lower carrier frequencies tend to increase motor heating. Specific conditions of use may be required to specify the minimum carrier frequency.
- Coolant
 - Maximum surface temperature determined with minimum rated flow / maximum rated coolant temperature
 - Specific conditions of use may be required to specify coolant requirements.

NOTE 3 The rotor can run significantly hotter than the stator. The significance of the problem varies with the type of protection. The determination of rotor temperature is particularly important for motors protected using types of protection “nA”, “e”, or some “px³” but could also be significant for types of protection “d”, “py”, “pz”, or “t”, when the hot rotor results in those high temperatures being transferred to the bearings and external shaft.

³ Type of protection “px” may require a mandatory “cool down” time to allow hot internal components to cool to the marked temperature class.

Annex F
(informative)

**Guideline flowchart for tests of non-metallic enclosures
or non-metallic parts of enclosures (26.4)**

NOTE This Annex only provides a general overview of the tests of enclosures required for the most common implementations of equipment. Specific attention needs to be paid to the detailed text of the applicable requirements when developing the test program for specific equipment.

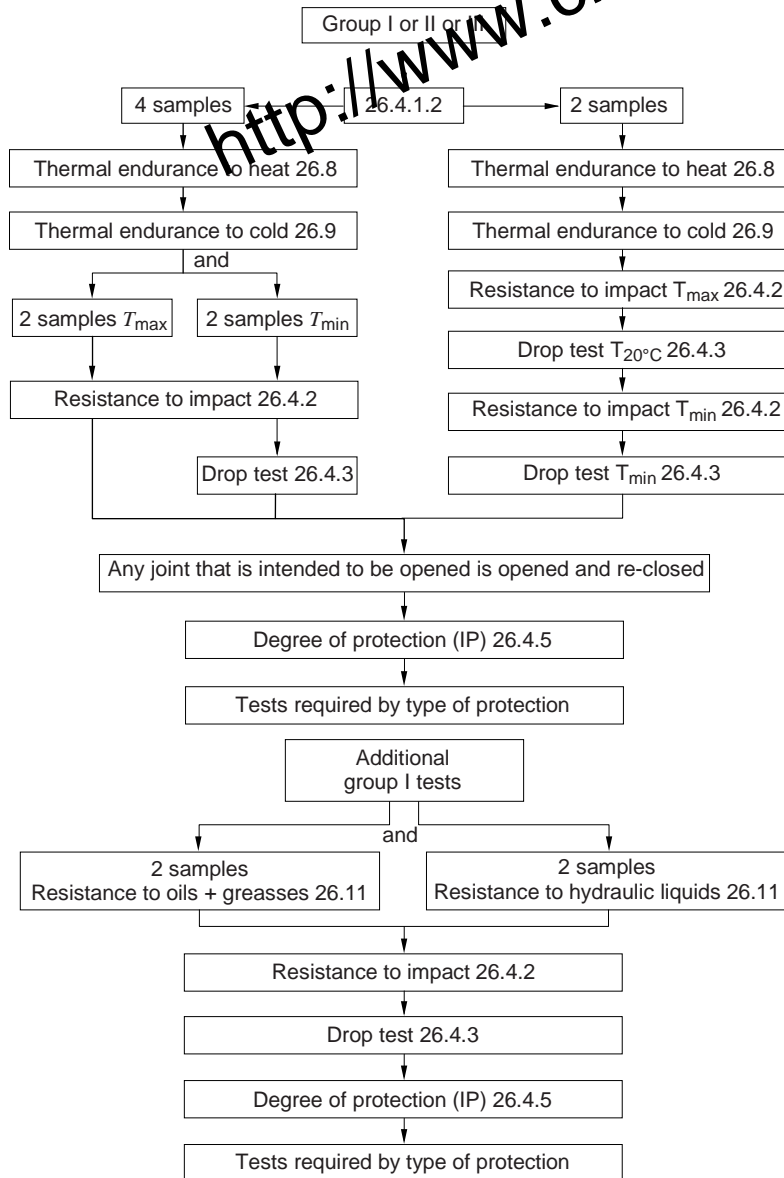

IEC 1142/11

Figure F.1 – Non-metallic enclosures or non-metallic parts of enclosures

Bibliography

IEC/TS 60034-17, *Rotating electrical machines – Part 17: Cage induction motors when fed from converters – Application guide*

IEC/TR 60034-25, *Rotating electrical machines – Part 25: Guidance for the design and performance of a.c. motors specifically designed for converter supply*

IEC 60034-29, *Rotating electrical machines – Part 29: Equivalent loading and superposition techniques – indirect testing to determine temperature rise*

IEC 60079-10-1, *Explosive atmospheres – Part 10-1: Classification of areas – Explosive gas atmospheres*

IEC 60079-10-2, *Explosive atmospheres – Part 10-2: Classification of areas – Combustible dust atmospheres*

IEC 60079-14, *Electrical apparatus for explosive gas atmospheres – Part 14: Electrical installations in hazardous areas (other than mines)*

IEC 60079-17, *Electrical apparatus for explosive gas atmospheres – Part 17: Inspection and maintenance of electrical installations in hazardous areas (other than mines)*

IEC 60079-19, *Explosive atmospheres – Part 19: Equipment repair, overhaul and reclamation*

IEC 60079-27, *Electrical apparatus for explosive gas atmospheres – Part 27: Fieldbus intrinsically safe concept (FISCO) and fieldbus non-incendive concept (FNICO)*

IEC/TS 60079-32, *Explosive atmospheres – Part 32: Electrostatics⁴*

IEC 61241-2-1:1994, *Electrical apparatus for use in the presence of combustible dust – Part 2: Test methods – Section 1: Methods for determining the minimum ignition temperatures of dust*

IEC/TR 61241-2-2, *Electrical apparatus for use in the presence of combustible dust – Part 2: Test methods – Section 2: Method for determining the electrical resistivity of dust in layers*

ISO/IEC 17000, *Conformity assessment – General vocabulary and general principles*

ISO 4225: 1994, *Air quality – General aspects – Vocabulary*

CLC/TR50427 – *Assessment of inadvertent ignition of flammable atmospheres by radio-frequency radiation – Guide*

IEEE/PCIC-2002-08 – R.F. Schiferl, M. J. Melfi, J. S. Wang, "Inverter driven induction motor bearing current solutions," 49th Annual IEEE Petroleum and Chemical Industry Conference, 23-25 Sept. 2002, pp. 67 – 75.

⁴ Under consideration.

<http://www.china-gauges.com/>

British Standards Institution (BSI)

BSI is the national body responsible for preparing British Standards and other standards-related publications, information and services.

BSI is incorporated by Royal Charter. British Standards and other standardization products are published by BSI Standards Limited.

About us

We bring together business, industry, government, consumers, innovators and others to shape their combined experience and expertise into standards-based solutions.

The knowledge embodied in our standards has been carefully assembled in a dependable format and refined through our open consultation process. Organizations of all sizes and across all sectors choose standards to help them achieve their goals.

Information on standards

We can provide you with the knowledge that your organization needs to succeed. Find out more about British Standards by visiting our website at bsigroup.com/standards or contacting our Customer Services team or Knowledge Centre.

Buying standards

You can buy and download PDF versions of BSI publications, including British and adopted European and international standards, through our website at bsigroup.com/shop, where hard copies can also be purchased.

If you need international and foreign standards from other Standards Development Organizations, hard copies can be ordered from our Customer Services team.

Subscriptions

Our range of subscription services are designed to make using standards easier for you. For further information on our subscription products go to bsigroup.com/subscriptions.

With **British Standards Online (BSOL)** you'll have instant access to over 55,000 British and adopted European and international standards from your desktop. It's available 24/7 and is refreshed daily so you'll always be up to date.

You can keep in touch with standards developments and receive substantial discounts on the purchase price of standards, both in single copy and subscription format, by becoming a **BSI Subscribing Member**.

PLUS is an updating service exclusive to BSI Subscribing Members. You will automatically receive the latest hard copy of your standards when they're revised or replaced.

To find out more about becoming a BSI Subscribing Member and the benefits of membership, please visit bsigroup.com/shop.

With a **Multi-User Network Licence (MUNL)** you are able to host standards publications on your intranet. Licences can cover as few or as many users as you wish. With updates supplied as soon as they're available, you can be sure your documentation is current. For further information, email bsmusales@bsigroup.com.

BSI Group Headquarters

389 Chiswick High Road London W4 4AL UK

Revisions

Our British Standards and other publications are updated by amendment or revision.

We continually improve the quality of our products and services to benefit your business. If you find an inaccuracy or ambiguity within a British Standard or other BSI publication please inform the Knowledge Centre.

Copyright

All the data, software and documentation set out in all British Standards and other BSI publications are the property of and copyrighted by BSI, or some person or entity that owns copyright in the information used (such as the international standardization bodies) and has formally licensed such information to BSI for commercial publication and use. Except as permitted under the Copyright, Designs and Patents Act 1988 no extract may be reproduced, stored in a retrieval system or transmitted in any form or by any means – electronic, photocopying, recording or otherwise – without prior written permission from BSI. Details and advice can be obtained from the Copyright & Licensing Department.

Useful Contacts:

Customer Services

Tel: +44 845 086 9001

Email (orders): orders@bsigroup.com

Email (enquiries): cservices@bsigroup.com

Subscriptions

Tel: +44 845 086 9001

Email: subscriptions@bsigroup.com

Knowledge Centre

Tel: +44 20 8996 7004

Email: knowledgecentre@bsigroup.com

Copyright & Licensing

Tel: +44 20 8996 7070

Email: copyright@bsigroup.com