

BS EN 60079-2:2014



BSI Standards Publication

# Explosive atmospheres

Part 2: Equipment protection by  
pressurized enclosure "p"

**bsi.**

...making excellence a habit.™

### National foreword

This British Standard is the UK implementation of EN 60079-2:2014. It is identical to IEC 60079-2:2014. It supersedes BS EN 60079-2:2007 and BS EN 61241-4:2006 which are withdrawn.

The UK participation in its preparation was entrusted to Technical Committee EXL/31, Equipment for explosive atmospheres.

A list of organizations represented on this committee can be obtained on request to its secretary.

This publication does not purport to include all the necessary provisions of a contract. Users are responsible for its correct application.

© The British Standards Institution 2015.

Published by BSI Standards Limited 2015

ISBN 978 0 580 78350 0

ICS 13.230; 29.260.20

**Compliance with a British Standard cannot confer immunity from legal obligations.**

This British Standard was published under the authority of the Standards Policy and Strategy Committee on 31 January 2015.

### Amendments/corrigenda issued since publication

Date	Text affected
------	---------------

---

EUROPEAN STANDARD

**EN 60079-2**

NORME EUROPÉENNE

EUROPÄISCHE NORM

December 2014

ICS 29.260.20

Supersedes EN 60079-2:2007, EN 61241-4:2006

English Version

Explosive atmospheres - Part 2: Equipment protection by  
 pressurized enclosure "p"  
 (IEC 60079-2:2014)

Atmosphères explosives - Partie 2: Protection du matériel  
 par enveloppe à surpression interne "p"  
 (IEC 60079-2:2014)

Explosionsgefährdete Bereiche - Teil 2: Geräteschutz durch  
 Überdruckkapselung "p"  
 (IEC 60079-2:2014)

This European Standard was approved by CENELEC on 2014-08-25. CENELEC members are bound to comply with the CEN/CENELEC Internal Regulations which stipulate the conditions for giving this European Standard the status of a national standard without any alteration.

Up-to-date lists and bibliographical references concerning such national standards may be obtained on application to the CEN-CENELEC Management Centre or to any CENELEC member.

This European Standard exists in three official versions (English, French, German). A version in any other language made by translation under the responsibility of a CENELEC member into its own language and notified to the CEN-CENELEC Management Centre has the same status as the official versions.

CENELEC members are the national electrotechnical committees of Austria, Belgium, Bulgaria, Croatia, Cyprus, the Czech Republic, Denmark, Estonia, Finland, Former Yugoslav Republic of Macedonia, France, Germany, Greece, Hungary, Iceland, Ireland, Italy, Latvia, Lithuania, Luxembourg, Malta, the Netherlands, Norway, Poland, Portugal, Romania, Slovakia, Slovenia, Spain, Sweden, Switzerland, Turkey and the United Kingdom.



European Committee for Electrotechnical Standardization  
 Comité Européen de Normalisation Electrotechnique  
 Europäisches Komitee für Elektrotechnische Normung

**CEN-CENELEC Management Centre: Avenue Marnix 17, B-1000 Brussels**

## Foreword

The text of document 31/1119/FDIS, future edition 6 of IEC 60079-2, prepared by IEC/TC 31 "Equipment for explosive atmospheres" was submitted to the IEC-CENELEC parallel vote and approved by CENELEC as EN 60079-2:2014.

The following dates are fixed:

- latest date by which the document has to be implemented at national level by publication of an identical national standard or by endorsement (dop) 2015-06-19
- latest date by which the national standards conflicting with the document have to be withdrawn (dow) 2017-08-25

This document supersedes EN 60079-2:2007 and EN 61241-4:2006.

The State of the Art is included in Annex ZY "Significant changes between this European Standard and EN 60079-2:2007".

For the significant changes with respect to EN 60079-2:2007, see Annex ZY.

This standard is to be read in conjunction with EN 60079-0.

Attention is drawn to the possibility that some of the elements of this document may be the subject of patent rights. CENELEC [and/or CEN] shall not be held responsible for identifying any or all such patent rights.

This document has been prepared under a mandate given to CENELEC by the European Commission and the European Free Trade Association, and supports essential requirements of EU Directive(s).

For the relationship with EU Directive(s) see informative Annex ZZ, which is an integral part of this document.

## Endorsement notice

The text of the International Standard IEC 60079-2:2014 was approved by CENELEC as a European Standard without any modification.

In the official version, for Bibliography, the following notes have to be added for the standards indicated:

IEC 60051	NOTE	Harmonized in EN 60051 series.
IEC 60079-1	NOTE	Harmonized as EN 60079-1.
IEC 60079-5	NOTE	Harmonized as EN 60079-5.
IEC 60079-6	NOTE	Harmonized as EN 60079-6.

IEC 60079-7	NOTE	Harmonized as EN 60079-7.
IEC 60079-13	NOTE	Harmonized as EN 60079-13.
IEC 60079-18	NOTE	Harmonized as EN 60079-18.
IEC 60079-20-1	NOTE	Harmonized as EN 60079-20-1.
IEC 60079-26	NOTE	Harmonized as EN 60079-26.
IEC 60079-28	NOTE	Harmonized as EN 60079-28.
IEC 61511	NOTE	Harmonized in EN 60079 series.

<http://www.china-gauges.com/>

**Annex ZA**  
(normative)

**Normative references to international publications  
with their corresponding European publications**

The following documents, in whole or in part, are normatively referenced in this document and are indispensable for its application. For dated references, only the edition cited applies. For undated references, the latest edition of the referenced document (including any amendments) applies.

NOTE 1 When an International Publication has been modified by common modifications, indicated by (mod), the relevant EN/HD applies.

NOTE 2 Up-to-date information on the latest versions of the European Standards listed in this annex is available here: [www.cenelec.eu](http://www.cenelec.eu)

<u>Publication</u>	<u>Year</u>	<u>Title</u>	<u>EN/HD</u>	<u>Year</u>
IEC 60034-5	-	Rotating electrical machines - Part 5: Degrees of protection provided by the integral design of rotating electrical machines (IP code) - Classification	EN 60034-5	-
IEC 60050	series	International Electrotechnical Vocabulary	-	-
IEC 60079-0	-	Explosive atmospheres - Part 0: Equipment - General requirements	EN 60079-0	-
IEC 60079-11	-	Explosive atmospheres - Part 11: Equipment protection by intrinsic safety "i"	EN 60079-11	-
IEC 60079-15	-	Explosive atmospheres - Part 15: Equipment protection by type of protection "n"	EN 60079-15	-
IEC 60112	-	Method for the determination of the proof and the comparative tracking indices of solid insulating materials	EN 60112	-
IEC 60127	series	Miniature fuses	EN 60127	series
IEC 60529	-	Degrees of protection provided by enclosures (IP Code)	EN 60529	-
IEC 60664-1	-	Insulation coordination for equipment within low-voltage systems - Part 1: Principles, requirements and tests	EN 60664-1	-

## Annex ZZ (informative)

### Coverage of Essential Requirements of EU Directives

This European Standard has been prepared under a mandate given to CEN/LEC by the European Commission and the European Free Trade Association and within its scope the standard covers only the following essential requirements out of those given in Annex II of the EU Directive 94/9/EC:

- ER 1.0.1 to ER 1.0.6;
- ER 1.2.1, ER 1.2.2 (partly), ER 1.2.3, ER 1.2.4 (partly), ER 1.2.6 to ER 1.2.8;
- ER 1.3.1, ER 1.3.5;
- ER 1.4.1 (partly);
- ER 1.5.1 to ER 1.5.8;
- ER 1.6.2 (partly), ER 1.6.3 to ER 1.6.5;
- ER 2.0.2.1, ER 2.0.2.2;
- ER 2.2.1, ER 2.2.1.1 to ER 2.2.1.3;
- ER 2.2.2.1 to 2.2.2.4;
- ER 2.3.1, ER 2.3.1.1, ER 2.3.1.2;
- ER 2.3.2.1 to 2.3.2.3.

Compliance with this standard provides one means of conformity with the specified essential requirements of the Directive[s] concerned.

**WARNING:** Other requirements and other EU Directives may be applicable to the products falling within the scope of this standard.

**Annex ZY**  
(informative)

**Significant changes between this European Standard and EN 60079-2:2007**

This European Standard supersedes EN 60079-2:2007.

The significant changes with respect to EN 60079-2:2007 are as listed below.

Table ZY.1

Changes	Clause	Type		
		Minor and editorial changes	Extension	Major technical changes
Scope Expanded to include combustible dust	1		X	
Protective Gas Replaced "apparatus" with "equipment"	3			
Protective Gas Revised to show that purging is not required for explosive dust atmospheres	3.16	X		
Level of Protection "pxb" Term and definitions revised to reflect EPL and level of protection	3.21	X		
Level of Protection "pyb" Term and definitions revised to reflect EPL and level of protection	3.22	X		
Level of Protection "pzc" Term and definitions revised to reflect EPL and level of protection	3.23	X		
Lower Flammable Limit Term and definition revised to agree with 60079-0	3.26	X		
Upper Flammable Limit Term and definition revised to agree with 60079-0	3.27	X		
Table 1 – Determination of protection level Revised to use EPL terminology	Table 1	X		
Table 2 – Design Criteria based upon level of protection Revised to use EPL terminology	Table 2	X		
Enclosure Requirements relaxed for specific designs	5.1		X	
Group II and Group III pressurized enclosures Text revised to use EPL terminology	5.3.3	X		
Group II and Group III Level of Protection "pxb" Added that warning also applies for explosive dust atmospheres	5.3.5		X	



Changes	Clause	Type		
		Minor and editorial changes	Extension	Major technical changes
Group II and Group III door and cover warning Added that warning also applies for explosive dust atmospheres	5.3.6		X	
Group II and Group III door and cover warning Revised warning from atmosphere "may be present" to "is present"	5.3.6	X		
Mechanical Strength Removed reference to 60079-0 by clause number for "X" condition	5.4	X		
Spark and particle barriers Removed reference to 60079-0 by clause number for "X" condition	5.9	X		
Cells and batteries Added requirements for cells and batteries	5.10			C1
For Level of Protection "pxb" or Level of Protection "pyb" Revised Table to use terminology consistent with EPLs	6.2	X		
Suitability of safety devices for hazardous area Word "explosion" changed to "ignition" to reflect UFL/LFL terms	7.1	X		
Integrity of safety devices Added requirement for detecting fan failure	7.2			C2
Table 3 – Safety devices based upon Level of Protection Revised column labels to use Level of Protection terminology	Table 3	X		
Provider of safety devices Remove reference to 60079-0 by clause number for "X" condition	7.3	X		
Pressurization System evaluated as associated equipment Added requirements for pressurization systems	7.4			C3
Sequence diagram for Level of Protection "pxb" Revised text to use Level of Protection terminology	7.5	X		
Group I and Group II purging automated for Level of Protection "pxb" Revised text to use Level of Protection terminology	7.7	X		
Group I and Group II purging automated for Level of Protection "pxb" Added text specifying that for "pxb", control must be automated	7.7			C4
Group I or Group II – purging criteria Revised text to use Level of Protection terminology	7.8	X		
Group III – cleaning Added text for cleaning enclosures used in explosive dust atmospheres	7.9		X	
Safety devices to detect minimum overpressure Add word "minimum" to clause title to be consistent with text	7.11	X		

Changes	Clause	Type		
		Minor and editorial changes	Extension	Major technical changes
Safety devices to detect minimum overpressure Revised text to use Level of Protection terminology	7.11 d)	X		
Value of minimum overpressure Added word "minimum" to clause title to be consistent with text	7.12	X		
Value of minimum overpressure Revised text to use Level of Protection terminology	7.12	X		
Value of minimum overpressure Added text to reflect a note in Annex C	7.12		X	
Pressurizing multiple enclosures Revised text to use Level of Protection terminology	7.13	X		
Safety devices on doors and covers Revised text to use Level of Protection terminology	7.14	X		
Equipment that may remain energized Revised text to use EPL and level of protection terminology	7.15	X		
Equipment permitted within Level of Protection "pyb" Revised text to use EPL and level of protection terminology	7.16	X		
Group I and Group II Filling procedure Allow filling in a hazardous location if tested as non-hazardous	8.4		X	
Group III Filling Procedure Added static pressurization filling procedure for combustible dust	8.5		X	
Safety devices Revised text to use Level of Protection terminology	8.6			
Equipment that may remain energized Revised text to use EPL terminology	8.7	X		
Overpressure Removed reference to 60079-0 by clause number	8.8	X		
Backup supply Added requirements for a backup supply of protective gas	9.1			C5
Independent supplies Provided requirements for independence of pressurization	9.2			C6
Release Conditions Removed reference to 60079-0 by clause number for "X" condition	11.1.2	X		
Containment system with a limited release Removed reference to 60079-0 by clause number for "X" condition	12.3	X		
13.3.3 Limited release of a gas or vapour Revised text to reflect UFL/LFL terms	13.3.3	X		
Ignition-capable equipment Revised text to use Level of Protection terminology	14	X		
Type verification and tests Edition 5 clauses 16.1 to 16.7 moved to Edition 6 clauses 16.2 to 16.8	16	X		

Changes	Clause	Type		
		Minor and editorial changes	Extension	Major technical changes
Determining the maximum overpressure rating Added requirements to determine maximum overpressure	16.1			
Maximum overpressure test Moved Maximum overpressure test to 16.2	16.2			C7
Maximum overpressure test Moved Maximum overpressure test to 16.2	16.3.2		X	
Tests for an infallible containment system Clarify the rating used for the test	16.7.1			C8
Tests for an infallible containment system Modified test for infallible containment	16.7.2			C9
Edition 5 – Verifying ability of the pressurized enclosure to limit internal pressure Eliminated test	16.8			C7
Functional test Clarified that applies only to safety devices provided with enclosures	17.1	X		
Tests for an infallible containment system Waived helium leak tests for liquid systems	17.3		X	
Supplementary marking Allowed continued use of type of protection marking	18.3			
Pressurization systems Clarified use of Ex [p] and [Ex p] marking	18.6	X		
Warnings required in other clauses Added table number	18.7	X		
Warnings required in other clauses Added warning from 7.9	18.7		X	
Warnings required in other clauses Added warnings from Annex G and Annex H	18.7			C1
Instructions Added requirements for Group III	19		X	
Edition 5 Annex G – Infallibility test for containment system Deleted and replaced	Annex G	X		
Edition 5 Annex H – Introduction of an alternative risk assessment method encompassing “equipment protection levels” Deleted and replaced	Annex H	X		
Annex G – Internal Cells and Batteries for Level of Protection “pxb” and Level of Protection “pyb” Added requirements for cells and Batteries			X	
Annex H – Internal Cells and Batteries for Level of Protection “pzc” Added requirements for cells and Batteries			X	

## CONTENTS

INTRODUCTION.....	14
1 Scope.....	15
2 Normative references .....	15
3 Terms and definitions .....	16
4 Protection levels .....	18
5 Constructional requirements for pressurized enclosures.....	21
5.1 Enclosure .....	21
5.2 Materials.....	21
5.3 Doors and covers.....	21
5.3.1 Group I pressurized enclosures .....	21
5.3.2 Group I pressurized enclosures with static pressurization.....	21
5.3.3 Group II and Group III pressurized enclosures .....	21
5.3.4 Group II and Group III pressurized enclosures with static pressurization.....	22
5.3.5 Group II and Group III Level of Protection “pxb” .....	22
5.3.6 Group II and Group III Door and Cover warning .....	22
5.4 Mechanical strength.....	22
5.5 Group I and Group II Apertures, partitions, compartments and internal components .....	22
5.6 Apertures for Static Pressurization.....	23
5.7 Insulating materials for Group I equipment.....	23
5.8 Sealing .....	23
5.9 Spark and particle barriers .....	23
5.10 Cells and batteries .....	24
6 Temperature limits.....	24
6.1 General.....	24
6.2 For Level of Protection “pxb” or Level of Protection “pyb”.....	24
6.3 For Level of Protection “pzc” .....	24
7 Safety provisions and safety devices (except for static pressurization) .....	24
7.1 Suitability of safety devices for hazardous area .....	24
7.2 Integrity of safety devices .....	24
7.3 Provider of safety devices.....	25
7.4 Pressurization System evaluated as associated equipment.....	25
7.4.1 Pressurization systems for Level of Protection “pzc” .....	25
7.4.2 Pressurization systems for Level of Protection “pyb”.....	26
7.4.3 Pressurization systems for Level of Protection “pxb”.....	26
7.5 Sequence diagram for Level of Protection “pxb” .....	26
7.6 Ratings for safety devices .....	26
7.7 Group I and Group II Purging automated for Level of Protection “pxb”.....	26
7.8 Group I or Group II – Purging criteria .....	27
7.9 Group III – Cleaning.....	27
7.10 Requirements when a minimum flow rate required .....	27
7.11 Safety devices to detect minimum overpressure.....	27
7.12 Value of minimum overpressure .....	28
7.13 Pressurizing multiple enclosures.....	29
7.14 Safety devices on doors and covers.....	29

7.15	Equipment that may remain energized .....	29
7.16	Equipment permitted within Level of Protection “pyb” .....	29
8	Safety provisions and safety devices for static pressurization .....	30
8.1	Suitability of safety devices for hazardous area .....	30
8.2	Protective gas .....	30
8.3	Internal sources of release .....	30
8.4	Group I and Group II Filling procedure .....	30
8.5	Group III Filling Procedure .....	30
8.6	Safety devices .....	30
8.7	Equipment that may remain energized .....	30
8.8	Overpressure .....	30
9	Supply of protective gas .....	31
9.1	Backup supply .....	31
9.2	Independent supplies .....	31
9.3	Type of gas .....	31
9.4	Temperature .....	31
10	Pressurized equipment with an internal source of release .....	31
11	Release conditions .....	31
11.1	No release .....	31
11.2	Limited release of a gas or vapour .....	32
11.3	Limited release of a liquid .....	32
12	Design requirements for the containment system .....	32
12.1	General design requirements .....	32
12.2	Infallible containment system .....	32
12.3	Containment system with a limited release .....	33
13	Protective gas and pressurizing techniques when there is an internal source of release .....	33
13.1	General .....	33
13.2	Pressurization with leakage compensation .....	34
13.2.1	No release .....	34
13.2.2	Limited release of a gas or liquid .....	34
13.3	Pressurization with dilution .....	34
13.3.1	General .....	34
13.3.2	No release .....	34
13.3.3	Limited release of a gas or vapour .....	35
13.3.4	Limited release of a liquid .....	35
14	Ignition-capable equipment .....	35
15	Internal hot surfaces .....	35
16	Type verification and tests .....	36
16.1	Determining the maximum overpressure rating .....	36
16.2	Maximum overpressure test .....	36
16.3	Leakage test .....	36
16.3.1	Other than static pressurization .....	36
16.3.2	Static pressurization .....	36
16.4	Purging test for pressurized enclosures with no internal source of release and filling procedure test for static pressurization .....	37
16.4.1	General .....	37
16.4.2	Pressurized enclosure where the protective gas is air .....	37

16.4.3	Pressurized enclosure where the protective gas is inert.....	37
16.4.4	Pressurized enclosure where the protective gas may be either air or an inert gas with a density equal to air $\pm 10\%$ .....	37
16.4.5	Filling procedure test for a pressurized enclosure protected by static pressurization.....	37
16.5	Purging and dilution tests for a pressurized enclosure with an internal source of release.....	37
16.5.1	Test gas.....	37
16.5.2	Pressurized enclosure where the flammable substance has less than 2% (V/V) oxygen and the protective gas is inert.....	38
16.5.3	Pressurized enclosure with pressurization by continuous flow, containment system with less than 21% (V/V) oxygen and the protective gas is inert.....	38
16.5.4	Pressurized enclosure where the flammable substance is not a liquid, pressurization by continuous flow and the protective gas is air.....	39
16.6	Verification of minimum overpressure.....	39
16.7	Tests for an infallible containment system.....	40
16.7.1	Overpressure test.....	40
16.7.2	Infallibility test.....	40
16.8	Overpressure test for a containment system with a limited release.....	40
17	Routine tests.....	40
17.1	Functional test.....	40
17.2	Leakage test.....	40
17.3	Tests for an infallible containment system.....	40
17.4	Test for a containment system with a limited release.....	40
18	Marking.....	40
18.1	General.....	40
18.2	Identifying as pressurized.....	41
18.3	Supplementary marking.....	41
18.4	Internal source of release.....	41
18.5	Static pressurization.....	41
18.6	Pressurization systems.....	41
18.7	Warnings required in other clauses.....	42
18.8	Overpressure limited by user.....	42
18.9	Inert gas.....	42
19	Instructions.....	43
Annex A (normative)	Purging and dilution tests.....	44
A.1	General.....	44
A.2	Criteria for compliance where the protective gas is air.....	44
A.3	Criteria for compliance where the protective gas is inert.....	44
Annex B (informative)	Examples of functional sequence diagram.....	45
Annex C (informative)	Examples of the changes in pressure in ducts and enclosures.....	47
Annex D (informative)	Information to be provided to the user.....	52
D.1	General.....	52
D.2	Ducting of protective gas.....	52
D.2.1	Location of inlet.....	52
D.2.2	Ducting between pressurized enclosure and inlet.....	52
D.2.3	Outlets for protective gas.....	52
D.2.4	Additional purge time to account for ducting.....	53

D.2.5	Temperature of protective gas at the inlet.....	53
D.3	Power for protective gas supply .....	53
D.4	Static pressurization .....	53
D.5	Enclosures with a containment system.....	53
D.6	Enclosure maximum overpressure .....	53
Annex E (normative)	Classification of the type of release within enclosures.....	54
E.1	General.....	54
E.2	No normal release, no abnormal release.....	54
E.3	No normal release, limited abnormal release.....	54
E.4	Limited normal release.....	54
Annex F (informative)	Examples for the use of the dilution area concept.....	55
Annex G (normative)	Internal Cells and Batteries for Level of Protection “pxb” and Level of Protection “pyb”.....	57
G.1	General Requirements .....	57
G.1.1	General .....	57
G.1.2	Accepted Electrochemical Systems .....	57
G.1.3	Secondary cells and secondary batteries.....	57
G.1.4	Mechanical Protection .....	57
G.2	Electrical Protection by energy limiting circuits.....	58
G.2.1	Assessing as energy limited .....	58
G.2.2	Protective Components.....	58
G.2.3	Preventing excessive gas pressure.....	58
G.3	Additional requirements for Primary batteries.....	59
G.3.1	Prevention of reverse charging. ....	59
G.3.2	Prevention of accidental charging of primary batteries .....	59
G.4	Additional requirements for secondary batteries.....	60
G.4.1	Charging of secondary batteries inside the pressurized housing .....	60
G.5	Specific requirements for Inherently Safe (IhS) cells and batteries .....	60
G.6	Equipment located inside a pressurized enclosure connected to a battery which is also located inside the pressurized enclosure and not disconnected in the event of loss of pressurization .....	61
G.6.1	General .....	61
G.6.2	Circuit Isolation.....	61
G.6.3	Intrinsically safe battery or inherently safe battery used with “Ex” equipment.....	61
G.6.4	Intrinsically Safe or Inherently Safe battery with non-“Ex” equipment.....	61
G.7	Supplementary marking and constructional requirements for pressurized enclosures containing one or more cells or batteries .....	63
G.7.1	General .....	63
G.7.2	Battery removal warning .....	63
G.7.3	Batteries requiring routine maintenance.....	63
G.8	Type tests .....	63
G.8.1	Voltage .....	63
G.8.2	Short circuit test for an Inherently Safe Cell or Battery.....	63
G.8.3	Full load test for other than Inherently safe batteries .....	63
Annex H (normative)	Internal Cells and Batteries for Level of Protection “pzc” .....	64
H.1	General Requirements .....	64
H.1.1	General .....	64
H.1.2	Accepted Electrochemical Systems .....	64

H.1.3	Secondary cells and secondary batteries .....	64
H.1.4	Mechanical Protection .....	64
H.2	Equipment located inside a pressurized enclosure connected to a battery which is also located inside the pressurized enclosure and is not disconnected when power is removed from the enclosure .....	65
H.3	Supplementary marking and constructional requirements for pressurized enclosures containing one or more cells or batteries .....	65
H.3.1	General .....	65
H.3.2	Battery removal warning .....	65
H.3.3	Batteries requiring routine maintenance .....	65
	Bibliography .....	66
	Figure B.1 – State diagram of a leakage-compensation purge control system .....	45
	Figure C.1 – Protective gas purge .....	48
	Figure C.2 – Pressurized enclosures with leakage compensation, enclosures without moving parts .....	49
	Figure C.3 – Pressurized enclosures with leakage compensation, rotating electrical machine with an internal cooling fan .....	50
	Figure C.4 – Pressurized enclosure with a leakage compensation, rotating electrical machine with an external cooling fan .....	51
	Figure F.1 – Diagram showing the use of the dilution area concept to simplify the purge and dilution test requirements .....	55
	Figure F.2 – Diagram showing the use of the infallible containment system concept to simplify the purging and dilution requirements around ICE .....	56
	Figure F.3 – Diagram showing the use of internal partitions around the potential source of release to simplify the purging and dilution requirements around ICE located outside the partitions .....	56
	Figure G.1 – Reverse charging protection .....	59
	Figure G.2 – Accidental charging protection .....	59
	Table 1 – Determination of protection level .....	19
	Table 2 – Design criteria based upon level of protection .....	20
	Table 3 – Safety devices based upon Level of Protection .....	25
	Table 4 – Protective gas requirements for a pressurized enclosure with a containment system .....	34
	Table 5 – Equipment Protection Levels permitted within the dilution area based upon the Level of Protection of the pressurized enclosure .....	35
	Table 6 – Text of warning markings .....	42
	Table B.1 – Truth table of a leakage-compensation purge control system .....	45



## INTRODUCTION

This part of IEC 60079 gives requirements for the design, construction, testing and marking of electrical equipment for use in explosive atmospheres in which

- a) a protective gas maintained at a pressure above that of the external atmosphere is used to guard against the formation of an explosive gas atmosphere within enclosures which do not contain an internal source of release of flammable gas or vapour;
- b) a protective gas maintained at a pressure above that of the external atmosphere is used to guard against the formation of an explosive gas atmosphere within enclosures and is supplied to an enclosure containing one or more internal sources of release in order to guard against the formation of an explosive gas atmosphere; or
- c) a protective gas maintained at a pressure above that of the external atmosphere, is used to prevent the entry of combustible dust which might otherwise lead to the formation of an explosive dust atmosphere within enclosures, but only where there is no internal source of release of combustible dust.

This standard includes requirements for the equipment and its associated equipment including the inlet and exhaust ducts, and also for the auxiliary control equipment necessary to ensure that pressurization and/or dilution is established and maintained.

## EXPLOSIVE ATMOSPHERES –

### Part 2: Equipment protection by pressurized enclosure "p"

#### 1 Scope

This part of IEC 60079 contains the specific requirements for the construction and testing of electrical equipment with pressurized enclosures, of type of protection "p", intended for use in explosive gas atmospheres or explosive dust atmospheres. It also includes the requirements for pressurized enclosures containing a limited release of a flammable substance.

This standard supplements and modifies the general requirements of IEC 60079-0. Where a requirement of this standard conflicts with a requirement of IEC 60079-0, the requirements of this standard take precedence.

This standard does not include the requirements for:

- pressurized enclosures where the containment system may release
  - a) air with an oxygen content greater than normal, or
  - b) oxygen in combination with inert gas where the oxygen is in a proportion greater than 21 %.
- pressurized rooms or analyser houses; see IEC 60079-13;
- pressurized enclosures used where "explosives" or pyrotechnics are present;
- pressurized enclosures used where hybrid mixtures of gas/vapour and combustible dust are present;
- pressurized enclosures used where pyrophoric substances such as explosives or propellants containing their own oxidizers are present
- pressurized enclosures with an internal source of release of combustible dust.

NOTE When the user acts in the role of the manufacturer, it is typically the user's responsibility to ensure that all relevant parts of this standard are applied to the manufacturing and testing of the equipment.

#### 2 Normative references

The following documents, in whole or in part, are normatively referenced in this document and are indispensable for its application. For dated references, only the edition cited applies. For undated references, the latest edition of the referenced document (including any amendments) applies.

IEC 60034-5, *Rotating electrical machines – Part 5: Degrees of protection provided by the integral design of rotating electrical machines (IP code) – Classification*

IEC 60050 (all parts), *International Electrotechnical Vocabulary*

IEC 60079-0, *Explosive atmospheres – Part 0: Equipment – General requirements*

IEC 60079-11, *Explosive atmospheres – Part 11: Equipment protection by intrinsic safety "i"*

IEC 60079-15, *Explosive atmospheres – Part 15: Equipment protection by type of protection "n"*

IEC 60112, *Method for the determination of the proof and the comparative tracking indices of solid insulating materials*

IEC 60127, (All parts) *Miniature fuses*

IEC 60529, *Degrees of protection provided by enclosures (IP Code)*

IEC 60664-1, *Insulation coordination for equipment within low-voltage systems – Part 1: Principles, requirements and tests*

### 3 Terms and definitions

For the purposes of this document, the terms and definitions given in IEC 60050-151, IEC 60050-426 and IEC 60079-0, as well as the following apply.

NOTE Unless otherwise specified, the terms "voltage" and "current" mean the r.m.s. values of an alternating, direct or composite voltage or current.

#### 3.1

##### **alarm**

piece of equipment that generates a visual or audible signal that is intended to attract attention

#### 3.2

##### **containment system**

part of the equipment containing the flammable substance that may constitute an internal source of release

#### 3.3

##### **dilution**

continuous supply of a protective gas, after purging, at such a rate that the concentration of a flammable substance inside the pressurized enclosure is maintained at a value outside the explosive limits at any potential ignition source (that is to say, outside the dilution area)

Note 1 to entry: Dilution of oxygen by inert gas may result in a concentration of flammable gas or vapour above the upper flammable limit (UFL).

#### 3.4

##### **dilution area**

area in the vicinity of an internal source of release where the concentration of a flammable substance is not diluted to a safe concentration

#### 3.5

##### **enclosure volume**

volume of the empty enclosure without internal equipment. For rotating electrical machines, the free internal volume plus the volume displaced by the rotor

#### 3.6

##### **flammable substance**

gases, vapours, liquids or mixtures thereof that are capable of being ignited

#### 3.7

##### **hermetically sealed device**

device which is so constructed that the external atmosphere cannot gain access to the interior and in which any seal is made by fusion

Note 1 to entry: Examples of fusion include brazing, welding or the fusion of glass to metal.

**3.8****ignition-capable equipment****ICE**

equipment which in normal operation constitutes a source of ignition for a specified explosive atmosphere.

**3.9****indicator**

piece of equipment that shows whether flow or pressure is adequate and which is intended to be monitored periodically, consistent with the requirement of the application

**3.10****internal source of release**

point or location from which a flammable substance in the form of a flammable gas or vapour or liquid may be released into the pressurized enclosure such that in the presence of air an explosive gas atmosphere could be formed

**3.11****leakage compensation**

provision of a flow of protective gas sufficient to compensate for any leakage from the pressurized enclosure and its ducts

**3.12****overpressure**

pressure above ambient pressure within a pressurized enclosure

**3.13****pressurization**

technique of guarding against the ingress of the external atmosphere into an enclosure by maintaining a protective gas therein at a pressure above that of the external atmosphere

**3.14****pressurization system**

grouping of safety devices and other components used to pressurize and monitor or control a pressurized enclosure

**3.15****pressurized enclosure**

enclosure in which a protective gas is maintained at a pressure greater than that of the external atmosphere

**3.16****protective gas**

air or inert gas used for maintaining an overpressure and, if required, dilution and purging

Note 1 to entry: For the purposes of this standard, inert gas means nitrogen, carbon dioxide, argon or any gas which, when mixed with oxygen in the ratio 4 parts inert to 1 part oxygen as found in air, does not make the ignition and flammability properties, such as explosive limits, more onerous.

**3.17****protective gas supply**

compressor, blower or compressed gas container that provides the protective gas at a positive pressure

Note 1 to entry: The protective gas supply includes inlet (suction) pipes or ducts, pressure regulators, outlet pipes, ducts, and supply valves.

Note 2 to entry: Components of the pressurization system other than the pressure regulator, are not included.

**3.18****purging**

in a pressurized enclosure, the operation of passing a quantity of protective gas through the enclosure and ducts, so that the concentration of the explosive gas atmosphere is brought to a safe level

**3.19****static pressurization**

maintenance of an overpressure within a pressurized enclosure without the addition of protective gas in a hazardous area

**3.20****Level of Protection “pxb”**

pressurized enclosure providing Equipment Protection Level Mb, Gb or Db

Note 1 to entry: This permits unprotected equipment to be installed within the pressurized enclosure except for safety devices, see 3.23.

**3.21****Level of Protection “pyb”**

pressurized enclosure providing Equipment Protection Level Gb or Db with Equipment Protection Level Gc or Dc internal to the pressurized enclosure

Note 1 to entry: This permits Equipment Protection Level Gc or Dc equipment to be installed within the pressurized enclosure, except for safety devices, see 3.23

**3.22****Level of Protection “pzc”**

pressurized enclosure providing Equipment Protection Level Gc or Dc

Note 1 to entry: This permits unprotected equipment to be installed within the pressurized enclosure except for safety devices, see 3.23.

**3.23****safety device**

device used to implement or maintain the integrity of the type of protection

**3.24****lower flammable limit****LFL**

volume fraction of flammable gas or vapour in air below which an explosive gas atmosphere will not form, expressed as a percentage (see IEC 60079-20-1)

Note 1 to entry: This is also known as Lower Explosive Limit (LEL).

**3.25****upper flammable limit****UFL**

volume fraction of flammable gas or vapour in air above which an explosive gas atmosphere will not form, expressed as a percentage (see IEC 60079-20-1)

Note 1 to entry: This is also known as Upper Explosive Limit (UEL).

**4 Protection levels**

Protection by pressurization is subdivided into three Levels of Protection (“pxb”, “pyb” and “pzc”) which are selected based upon the Equipment Protection Level required (Mb, Gb, Db, Gc or Dc), whether there is the potential for an internal release, and whether the equipment within the pressurized enclosure is ignition-capable; see Table 1. The Level of Protection then

defines design criteria for the pressurized enclosure and the pressurization system; see Table 2.

**Table 1 – Determination of protection level**

Is there an internal release condition?	Highest Equipment Protection Level requirement for external explosive atmosphere	Does enclosure contain ignition-capable equipment?	Level of Protection
No	Mb, Gb or Db	Yes or no	Level of Protection "pxb"
No	Gb or Db	No	Level of Protection "pyb"
No	Gc or Dc	Yes or no	Level of Protection "pzc"
Yes, gas/vapour	Mb, Gb, or Db	No or Yes and the ignition-capable equipment is not located in the dilution area	Level of Protection "pxb"
Yes, gas/vapour	Gb or Db	No	Level of Protection "pyb"
Yes, gas/vapour	Gc or Dc	Yes and the ignition-capable equipment is not located in the dilution area	Level of Protection "pxb"
Yes, gas/vapour	Gc or Dc	No	Level of Protection "pyb"
Yes liquid	Gb or Db	Yes or No	Level of Protection "pxb" (inert)
Yes liquid	Gb or Db	No	Level of Protection "pyb" (inert)
Yes liquid	Gc or Dc	Yes or No	Level of Protection "pzc" (inert)
If the flammable substance is a liquid, normal release is never permitted.			
The protective gas shall be inert if "(inert)" is shown after the pressurization level; see Clause 13.			

Table 2 – Design criteria based upon level of protection

Design criteria	Level of Protection "pxb"	Level of Protection "pyb"	Level of Protection "pzc" with indicator	Level of Protection "pzc" with alarm
Degree of enclosure protection according to IEC 60529 or IEC 60034-5	IP4X minimum	IP4X minimum	IP4X minimum	IP3X minimum
Resistance of enclosure to impact	IEC 60079-0 applies	IEC 60079-0 applies	IEC 60079-0 applies	apply half the value shown in IEC 60079-0
Verifying purge period for Group I and Group II	Requires a timing device and monitoring of pressure and flow	Time and flow marked	Time and flow marked	Time and flow marked
Preventing incandescent particles from exiting a normally closed relief vent into an area requiring EPL Mb, Gb or Db	Spark and particle barrier required, see 5.9, unless incandescent particles not normally produced	No requirement <sup>a)</sup>	Level of protection "pzc" does not apply to areas requiring EPL Mb, Gb or Db	Level of protection "pzc" does not apply to areas requiring EPL Mb, Gb or Db
Preventing incandescent particles from exiting a normally closed relief vent into an area requiring EPL Gc or Dc	No requirement <sup>b)</sup>	No requirement <sup>b)</sup>	No requirement, see footnote b)	No requirement <sup>b)</sup>
Preventing incandescent particles from exiting a vent that opens during normal operation, to an area requiring EPL Mb, Gb or Db	Spark and particle barrier required, see 5.9	Spark and particle barrier required, see 5.9	Level of Protection "pzc" does not apply to areas requiring EPL Mb, Gb or Db	Level of Protection "pzc" does not apply to areas requiring EPL Mb, Gb or Db
Preventing incandescent particles from exiting a vent that opens during normal operation to an area requiring EPL Gc, or Dc	Spark and particle barrier required, see 5.9, unless incandescent particles not normally produced	No requirement <sup>a)</sup>	Spark and particle barrier required, see 5.9, unless incandescent particles not normally produced	Spark and particle barrier required, see 5.9, unless incandescent particles not normally produced
Door or cover opens only with use of a tool	Warning, see 5.3 and 6.2 b) ii)	Warning, see 5.3.6 <sup>b)</sup>	Warning, see 5.3.6 <sup>c)</sup>	Warning, see 5.3.6 <sup>c)</sup>
Door or cover opens without use of a tool	Interlock, see 7.14 (no internal hot parts)	Warning, see 5.3.6 <sup>a)</sup>	Warning, see 5.3.6 <sup>c)</sup>	Warning, see 5.3.6 <sup>c)</sup>
Internal hot parts that require a cool-down period before opening enclosure	Comply with 6.2 b) ii)	No requirement <sup>a)</sup>	Warning, see 5.3.6	Warning, see 5.3.6
<p>a) 6.2b) ii) is not applicable for Level of Protection "pyb" since neither hot internal parts nor normally created incandescent particles are permitted.</p> <p>b) There is no requirement for spark and particle barriers since in abnormal operation, where the relief vent opens, it is unlikely that the external atmosphere is within the explosive limits.</p> <p>c) There is no requirement for tool accessibility on a Level of Protection "pzc" enclosure since in normal operation the enclosure is pressurized with all covers and doors in place. If a cover or door is removed, it is unlikely that the atmosphere is within the explosive limits.</p>				

## 5 Constructional requirements for pressurized enclosures

### 5.1 Enclosure

The pressurized enclosure shall have a degree of protection in accordance with Table 2.

For Level of Protection “pxb” with no internal components that exceed the marked temperature class and for Levels of Protection “pyb” and “pzc”, the tests for thermal endurance to heat and thermal endurance to cold for non-metallic enclosures and non-metallic parts of enclosures of IEC 60079-0 need not be applied to the pressurized enclosure.

This is because degradation of the enclosure that results in increased leakage will result in alarm or removal of power to ignition capable circuits. Therefore, the pre-conditioning testing of non-metallic enclosures and non-metallic parts of enclosures is not considered necessary.

### 5.2 Materials

The materials used for the enclosure, ducts and connecting parts shall not be adversely affected by the specified protective gas.

### 5.3 Doors and covers

#### 5.3.1 Group I pressurized enclosures

Doors and covers shall either

- have special fasteners complying with IEC 60079-0; or
- be interlocked so that the electrical supply to equipment not providing an EPL as shown in 7.15 is disconnected automatically when they are opened and so that the supply cannot be restored until they are closed. The requirements of 7.7 shall also apply.

#### 5.3.2 Group I pressurized enclosures with static pressurization

Doors and covers shall have special fasteners complying with IEC 60079-0.

#### 5.3.3 Group II and Group III pressurized enclosures

The requirements for special fasteners in IEC 60079-0 do not apply.

For Level of Protection “pxb”, doors and covers which can be opened without the use of a tool or key shall be interlocked so that the electrical supply to electrical equipment not identified in 7.15 is disconnected automatically when they are opened and so that the supply cannot be restored until they are closed.

For Level of Protection “pyb” and Level of Protection “pzc”, the use of a tool or key is not required.

Consideration should be given to the possibility that the internal pressure could cause a door or cover to open violently when the fastener is moved. The operator or maintenance personnel should be protected from injury by methods such as the following:

- a) use multiple fasteners so that the enclosure will safely vent before all fasteners are released; or
- b) use a two-position fastener to allow safe venting of the pressure when opening the enclosure; or
- c) limit the maximum internal pressure to not greater than 2,5 kPa.



#### 5.3.4 Group II and Group III pressurized enclosures with static pressurization

Doors and covers shall not be capable of being opened readily without the use of a key or tool

#### 5.3.5 Group II and Group III Level of Protection “pxb”

A pressurized enclosure that contains hot parts requiring a cool-down period shall not be capable of being opened readily without the use of a key or tool.

#### 5.3.6 Group II and Group III Door and Cover warning

To prevent the ignition of an explosive gas atmosphere or an explosive dust atmosphere which may be present when an enclosure is opened, doors and covers shall be marked:

WARNING – DO NOT OPEN WHEN AN EXPLOSIVE ATMOSPHERE IS PRESENT.

#### 5.4 Mechanical strength

The pressurized enclosure, ducts if any, and their connecting parts shall withstand a pressure equal to 1,5 times the maximum overpressure specified by the manufacturer for normal service with all outlets closed with a minimum of 200 Pa.

If a pressure can occur in service that can cause a deformation of the enclosure, ducts if any, or connecting parts, a safety device shall be fitted to limit the maximum internal overpressure to a level below that which could adversely affect the type of protection. If the manufacturer does not provide the safety device, the certificate number shall include the "X" suffix in accordance with the marking requirements of IEC 60079-0 and the Specific Conditions of Use listed on the certificate shall detail the necessary information required by the user to ensure conformity with the requirements of this standard.

#### 5.5 Group I and Group II Apertures, partitions, compartments and internal components

5.5.1 Apertures and partitions shall be located in such a way that effective purging is ensured.

Unpurged areas can be eliminated by the proper location of the protective gas supply inlet and outlet and by consideration of the effect of partitions.

For gases or vapours that are heavier than air the inlet for the protective gas should be near the top of the pressurized enclosure, with the outlet near the bottom of the enclosure.

For gases or vapours that are lighter than air, the inlet for the protective gas should be near the bottom of the enclosure, with the outlet near the top of the enclosure.

Locating inlets and outlets at opposite sides of the enclosure promotes cross ventilation.

Internal partitions (for example, circuit boards) should be located in such a way that the flow of protective gas is not obstructed. The use of a manifold or baffles can also improve the flow around obstructions.

The number of apertures should be chosen with regard to the design of the equipment, particular consideration being given to the purging of sub-compartments into which the equipment might be divided.

5.5.2 Internal compartments shall be vented to the main enclosure or separately purged.

Vents providing not less than 1 cm<sup>2</sup> of vent area for each 1 000 cm<sup>3</sup>, with a minimum vent size of 6,3 mm diameter are typically sufficient for adequate purging.

**5.5.3** Cathode ray tubes (CRTs) and other hermetically sealed devices do not require purging.

**5.5.4** Components with a free internal volume less than 20 cm<sup>3</sup> are not considered to be internal compartments requiring purging as long as the total volume of all such components is not more than 1 % of the free internal volume of the pressurized equipment.

NOTE 1 The 1 % is based upon 25 % of the lower explosive limit (LFL) of hydrogen, see A2.

Electrical components considered to be environmentally sealed such as transistors, micro-circuits, capacitors, etc., are not to be included in the calculation of the total component volume.

## **5.6 Apertures for Static Pressurization**

The enclosure shall have one or more aperture(s). After filling and pressurization, all apertures shall be closed.

## **5.7 Insulating materials for Group I equipment**

Insulating materials subjected to electrical stresses capable of causing arcs in air and which result from rated currents of more than 16 A (in switching equipment such as circuit-breakers, contactors, isolators) shall have at least one of the following:

- a comparative tracking index equal to or greater than CTI 400 M in accordance with IEC 60112;
- a suitable device which detects possible decomposition of the insulating materials inside the enclosure leading to a dangerous condition, and automatically disconnects the power supply to the enclosure on the supply side, the presence and function of such a device shall be verified;
- creepage distances between live exposed conductors complying with those shown for the equivalent voltage in Material Group III (CTI) of pollution degree 3 in IEC 60664-1.

## **5.8 Sealing**

All cable and conduit connections to a pressurized enclosure shall be sealed to maintain the IP rating of the enclosure or, if unsealed, be considered as part of the enclosure.

## **5.9 Spark and particle barriers**

The pressurized enclosure and the ducting, if any, for the protective gas shall be provided with a spark and particle barrier to guard against the ejection of incandescent particles into the hazardous area.

Incandescent particles shall be assumed to be normally produced unless make/break contacts operate at less than 10 A and the working voltage does not exceed either 275 V a.c. or 60 V d.c., and the contacts have a cover.

Enclosures in which incandescent particles are not normally produced, do not require a spark and particle barrier on any normally closed relief vent exhausting into an area requiring EPL Gb or Mb.

Enclosures in which incandescent particles are not normally produced, do not require a spark and particle barrier on any vent exhausting into an area requiring EPL Gc.

If the manufacturer does not provide the spark and particle barriers, the certificate number shall include the "X" suffix in accordance with the marking requirements of IEC 60079-0 and the Specific Conditions of Use listed on the certificate shall detail the necessary information required by the user to ensure conformity with the requirements of this standard.

## 5.10 Cells and batteries

Annex G provides requirements for Levels of Protection “pxb” and “pyb”. Annex H provides requirements for Level of Protection “pzc”.

## 6 Temperature limits

### 6.1 General

The equipment shall be classified in accordance with the temperature classification requirements of IEC 60079-0. The temperature class shall be determined in accordance with 6.2 and 6.3.

### 6.2 For Level of Protection “pxb” or Level of Protection “pyb”

The temperature class shall be based on the higher of the following temperatures:

- a) the hottest external surface of the enclosure; or
- b) the hottest internal component surface.

Exception: An internal component may exceed the marked temperature class if

- i) it complies with the relevant “small component” requirements of IEC 60079-0, or
- ii) the pressurized enclosure is Level of Protection “pxb” and complies with the requirements for opening times in IEC 60079-0. Appropriate measures shall be taken to prevent, if pressurization ceases, any explosive gas atmosphere which may exist making contact with the hot component surface before it has cooled below the permitted maximum value.

This may be achieved either by the design and construction of the joints of the pressurized enclosure and ducts or by other means, for example, by bringing auxiliary ventilation systems into operation or by arranging that the hot surface within the pressurized enclosure is in a gas-tight or encapsulated housing.

For Level of Protection “pyb”, hot ignition-capable parts in normal operation are not permitted within the enclosure.

### 6.3 For Level of Protection “pzc”

The temperature class shall be based on the hottest external surface of the enclosure.

In determining temperature class, account should be taken of any internal equipment with its own explosion protection, which may remain energized when the pressurization system is switched off.

## 7 Safety provisions and safety devices (except for static pressurization)

### 7.1 Suitability of safety devices for hazardous area

All safety devices used to reduce electrical equipment protected by pressurization from causing ignition shall themselves not be capable of causing ignition (see 7.15) or shall be mounted outside the hazardous area.

### 7.2 Integrity of safety devices

The safety devices required by this standard (see Table 3) form safety related parts of a control system. The safety and integrity of the control system shall be consistent with:

- for Level of Protection “pxb” or Level of Protection “pyb”, a single fault evaluation;

– for Level of Protection “pzc”, normal operation.

NOTE For guidance on the single fault evaluation, IEC 61511 series or similar standards can be used.

An electrical interlock on the fan motors or controls is not sufficient to indicate failure of pressurization because this may not indicate failures such as the fan belt slipping, the fan becoming loose on the shaft or reverse rotation of the fan.

**Table 3 – Safety devices based upon Level of Protection**

Design criteria	Level of Protection “pxb”	Level of Protection “pzb”	Level of Protection “pzc”
Safety device to detect loss of minimum overpressure	Pressure sensor, see 7.11	Pressure sensor, see 7.11	Indicator or pressure sensor, see 7.11 d)
Safety device(s) to verify purge period for Group I and Group II	Timing device, pressure sensor, flow sensor at outlet, see 7.7	Time and flow marked, see 7.8 c)	Time and flow marked, see 7.8 c)
Safety device for a door or cover removable only with use of a tool	Warning, see 6.2 b)	No requirement (internal hot parts not permitted)	No requirement
Safety device for a door or cover removable without use of a tool	Interlock, see 7.14 (internal hot parts not permitted)	No requirement (internal hot parts not permitted)	No requirement
Safety device for hot internal parts when there is a containment system (see Clause 15)	Alarm and stop flow of flammable substance	Not applicable for protection level since internal hot parts not permitted	Alarm (normal release not permitted)

### 7.3 Provider of safety devices

The safety devices shall be provided by the manufacturer of the equipment or by the user. If the manufacturer does not provide the safety devices, the certificate number shall include the "X" suffix in accordance with the marking requirements of IEC 60079-0 and the Specific Conditions of Use listed on the certificate shall detail the necessary information required by the user to ensure conformity with the requirements of this standard.

### 7.4 Pressurization System evaluated as associated equipment

#### 7.4.1 Pressurization systems for Level of Protection “pzc”.

The pressurization system shall include as a minimum: a means for controlling the minimum overpressure, (e.g. a regulator) and a means to verify the minimum overpressure, (e.g. an indicator) all in accordance with 7.11.

If a vent is provided, it shall have a spark and particle barrier.

If a regulator is provided and if it is of a type that a single failure mode will put full inlet pressure on the regulator outlet, then a means (e.g. relief vent) shall be provided that will limit the internal pressure of an enclosure to a defined value. This value is to be stated in the instructions and established by either test or calculation. If multiple regulators or relief vents are provided as options, then the value for each set of available regulator/relief vent options shall be determined.

The pressurization system shall be tested to verify correct operation.

#### 7.4.2 Pressurization systems for Level of Protection "pyb".

The pressurization system shall include: a means for controlling the minimum overpressure, (e.g. a regulator), a means to verify the minimum overpressure, (e.g. a pressure sensor) and an automatic safety device all in accordance with 7.11.

If a regulator is provided and if it is of a type that a single failure mode will put full inlet pressure on the regulator outlet, then a means (e.g. relief vent) shall be provided that will limit the internal pressure of an enclosure to a defined value. This value is to be stated in the instructions and established by either test or calculation. If multiple regulators or relief vents are provided as options, then the value for each set of available regulator/relief vent options shall be determined.

The pressurization system shall be tested to verify correct operation.

#### 7.4.3 Pressurization systems for Level of Protection "pxb".

The pressurization system shall include: a means for controlling the minimum overpressure, (e.g. a regulator), a means to verify the minimum overpressure, (e.g. a pressure sensor), an automatic safety device all in accordance with 7.11 and an automated control system incorporating a flow sensor in accordance with 7.7.

If a regulator is provided and if it is of a type that a single failure mode will put full inlet pressure on the regulator outlet, then a means (e.g. relief vent) shall be provided that will limit the internal pressure of an enclosure to a defined value. This value is to be stated in the instructions and established by either test or calculation. If multiple regulators or relief vents are provided as options, then the value for each set of available regulator/relief vent options shall be determined.

The pressurization system shall be tested to verify correct operation including the function of the automatic control system.

#### 7.5 Sequence diagram for Level of Protection "pxb"

For Level of Protection "pxb" pressurization systems, a functional sequence diagram shall be provided by the manufacturer, for example, truth table, state diagram, flow chart, etc., to define the action of the control system. The sequence diagram shall clearly identify and show the operational states of the safety devices and ensuing actions. Functional tests shall be required to verify conformity to the diagram. These tests need be carried out under normal atmospheric conditions, only unless otherwise specified by the manufacturer.

NOTE An example of the information to be supplied by the manufacturer is given in Annex B.

#### 7.6 Ratings for safety devices

The manufacturer shall specify the maximum and minimum action levels and tolerances of the safety devices. The safety devices shall be used within the ratings specified by the manufacturer.

#### 7.7 Group I and Group II Purging automated for Level of Protection "pxb"

An automatic control system including safety devices shall be provided to energize the electrical equipment within a pressurized enclosure only after purging has been completed.

The sequence of operations of the control system shall be as follows:

- a) following the initiation of the sequence, the purging flow through and the minimum overpressure in the pressurized enclosure shall be monitored in accordance with this standard;

- b) when the minimum flow rate of protective gas is achieved and the overpressure is within the specified limits, the purge timer can be started;
- c) after expiry of the time, the electrical equipment is then available to be energized;
- d) in the event of failure of any step in the sequence, the circuit shall be arranged to reset to the beginning.

### 7.8 Group I or Group II – Purging criteria

The manufacturer shall specify the conditions required for proper purging after an enclosure has been opened or the overpressure has dropped below the minimum specified by the manufacturer.

- a) for Level of Protection “pxb” or Level of Protection “pyb”, the manufacturer shall specify the minimum purge flow and time to satisfy the test in 16.4 or 16.5 as appropriate. For other than rotating machines and equipment with complex geometries, the minimum purge flow and time may be based upon a five-enclosure-volume purge if it is determined that such a purge is adequate without test.
- b) for Level of Protection “pzc”, for other than rotating machines and equipment with complex geometries, the manufacturer shall specify the minimum purge flow and time to ensure that the pressurized enclosure is purged by a quantity of protective gas equivalent to five enclosure volumes. The quantity of protective gas may be reduced if effective purging is demonstrated by the test in 16.4 or 16.5, as appropriate.

The purge test for rotating machines and for equipment with complex geometries may be omitted if the purge time is based on tests made with similar or comparable enclosures.

- c) the purging flow rate shall be monitored at the outlet of the pressurized enclosure. For Level of Protection “pxb”, the actual flow shall be monitored. For Level of Protection “pyb” or Level of Protection “pzc”, the flow may be deduced, for example, from the enclosure pressure and a defined orifice at the outlet. For Level of Protection “pyb” or Level of Protection “pzc”, an instruction label shall be provided to permit purging the pressurized enclosure before energizing the electrical equipment. The label shall include the following or similar:

WARNING – POWER SHALL NOT BE RESTORED AFTER ENCLOSURE HAS BEEN OPENED UNTIL ENCLOSURE HAS BEEN PURGED FOR \_\_\_ MINUTES AT A FLOW RATE OF \_\_\_\_.

NOTE It is typically the user's responsibility to determine the free space of the associated ducts which are not part of the equipment and to set up the additional purging time for the given minimum flow rate.

### 7.9 Group III – Cleaning

A warning shall be marked on the equipment stating that combustible dust shall be removed from the interior prior to switching on the electrical supply. The marking shall include the following or similar:

WARNING – POWER SHALL NOT BE RESTORED AFTER THE ENCLOSURE HAS BEEN OPENED UNTIL COMBUSTIBLE DUST ACCUMULATIONS WITHIN THE ENCLOSURE HAVE BEEN REMOVED.

### 7.10 Requirements when a minimum flow rate required

When a minimum rate of flow of protective gas is specified by the manufacturer (for example, if internal equipment would develop temperatures hotter than the marked temperature classification rating), one (or more) automatic safety device(s) shall be provided to operate when the flow rate of protective gas at the outlet falls below the specified minimum value.

### 7.11 Safety devices to detect minimum overpressure

One or more automatic safety devices shall be provided to operate when the pressurized enclosure overpressure falls below the minimum value specified by the manufacturer.



- a) the automatic safety device sensor shall take its signal directly from the pressurized enclosure:
- b) no valves shall be permitted between the automatic safety device sensor and the pressurized enclosure:
- c) it shall be possible to check the correct operation of the safety devices. Their location and setting shall take into account the requirements of 7.12:

NOTE The purpose(s) for which the automatic safety device(s) are used (i.e. to disconnect power or to sound an alarm or otherwise ensure the safety of the installation) is typically the responsibility of the user.

- d) for Level of Protection “pzc”, the following conditions shall be observed if the pressurized enclosure is equipped with an indicator in place of the automatic safety device:
  - 1) the protective gas supply shall be equipped with an alarm to indicate failure of the protective gas supply to maintain the minimum pressurized enclosure pressure;
  - 2) there shall be no devices between the pressurized enclosure and the protective gas supply alarm other than an isolating valve and/or a pressure or flow controlling mechanism;
  - 3) any isolating valve shall
    - be marked

**WARNING – PROTECTIVE GAS SUPPLY VALVE – FOLLOW INSTRUCTIONS BEFORE CLOSING**

- be capable of being sealed or secured in the open position;
- have an indication of whether it is open or closed;
- be located immediately adjacent to the pressurized enclosure;
- be used only during servicing of the pressurized enclosure.

NOTE This valve is intended to be kept open unless the area is known to be free of an explosive gas atmosphere or unless all equipment within the pressurized enclosure is de-energised and cooled.

- 4) any pressure or flow controlling mechanism, if adjustable, shall require a tool to operate it;
- 5) no filters shall be fitted between the pressurized enclosure and the protective gas system alarm;
- 6) the indicator shall be located for convenient viewing;
- 7) the indicator shall indicate the enclosure pressure;
- 8) the sensing point for the indicator shall be located to take into account the most onerous conditions of service;
- 9) the exclusion for non-metallic enclosures and non-metallic parts of enclosures in 5.1 has not been applied;
- 10) no isolating valve shall be fitted between the indicator and the pressurized enclosure.

A flowmeter used to indicate both enclosure pressure and purging flow normally should be located on the outlet.

A flowmeter used only to indicate pressure normally may be located anywhere on the enclosure, except the inlet.

NOTE Only in exceptional circumstances will a flowmeter located at the inlet indicate the pressure in the enclosure or the flow through the enclosure.

### 7.12 Value of minimum overpressure

A minimum overpressure of 50 Pa for Level of Protection “pxb” or Level of Protection “pyb”, and 25 Pa for Level of Protection “pzc” shall be maintained relative to the external pressure at every point, within the pressurized enclosure and its associated ducts, at which leakage can occur.

The manufacturer shall specify the minimum and maximum normal overpressure in service, the maximum overpressure during purging and the maximum leakage rate at the maximum normal overpressure.

Consideration should be given in the application of pressurized equipment having an internally enclosed cooling circuit in which circulation is assisted by an internal fan (e.g. motors), since the effect of such fans may be to produce a negative pressure in parts of the casing with consequent risk of ingress of gas or dust if pressurization ceases (see Figure C.3).

The distribution of pressure in different systems and ducts is illustrated in Figures C.1 to C.4.

The installation of the associated ducts and of the compressor or fan should not introduce a hazard. The basic requirements for the installation of ducting systems are given in Annex D.

### 7.13 Pressurizing multiple enclosures

When a source of protective gas is common to a number of separate pressurized enclosures, the safety device or devices may be common to several of these, provided that the resulting control takes account of the most unfavourable configuration of the group of enclosures. When a common safety device is fitted, the opening of a door or cover need not switch off all the electrical equipment in the pressurized enclosures or initiate the alarm, provided that the following three conditions are met:

- a) for Level of Protection “pxb”, the opening of the door or cover shall be preceded by disconnecting the supply to the electrical equipment in the particular pressurized enclosure, except if permitted by 7.15;
- b) the common safety device continues to monitor the overpressure in, and where necessary the flow through, all the other pressurized enclosures of the group; and
- c) the subsequent connecting of the supply to the electrical equipment in the particular pressurized enclosure is preceded by the purging procedure specified in 7.7.

### 7.14 Safety devices on doors and covers

For Level of Protection “pxb”, doors and covers that can be opened without the use of a tool or key, shall be interlocked so that the electrical supply to electrical equipment not identified in 7.15 is disconnected automatically when they are opened and so that the supply cannot be restored until they are closed. The requirements of 7.7 shall also apply.

### 7.15 Equipment that may remain energized

For Group I or Group II pressurized enclosures, the electrical equipment that may remain energized when Level of Protection “pxb” or Level of Protection “pyb” is not in operation shall be protected by EPL Ma or Mb for Group I and EPL Ga or Gb for Group II.

For Group II pressurized enclosures, the electrical equipment that may remain energized when Level of Protection “pzc” is not in operation shall be protected by EPL Ga, Gb or Gc.

For Group III pressurized enclosures, the electrical equipment that may remain energized when Level of Protection “pxb” is not in operation shall be protected by EPL Da or Db.

For Group III pressurized enclosures, the electrical equipment that may remain energized when Level of Protection “pzc” is not in operation shall be protected by EPL Da, Db or Dc.

### 7.16 Equipment permitted within Level of Protection “pyb”

Electrical equipment within a Level of Protection “pyb” pressurized enclosure shall be protected by EPL Ga, Gb or Gc for Group II.



Electrical equipment within a Level of Protection “pyb” pressurized enclosure shall be protected by EPL Da, Db, Dc for Group III.

## **8 Safety provisions and safety devices for static pressurization**

### **8.1 Suitability of safety devices for hazardous area**

All safety devices used to prevent electrical equipment protected by static pressurization causing an explosion shall themselves not be capable of causing an explosion and, if the safety device is electrically operated, it shall be protected by one of the types of protection recognized in IEC 60079-0 which is suitable for the application, or shall be mounted outside the hazardous area.

### **8.2 Protective gas**

The protective gas shall be inert.

### **8.3 Internal sources of release**

There shall be no internal sources of release.

### **8.4 Group I and Group II Filling procedure**

The Instructions shall specify that the pressurized enclosure shall be filled with inert gas in an area known to be non-hazardous using the procedure specified by the manufacturer.

### **8.5 Group III Filling Procedure**

The Instructions shall specify that the pressurized enclosure shall be cleaned as necessary to ensure there is no hazardous accumulation of combustible dust within the enclosure. The Instructions shall specify that after cleaning, the pressurized enclosure shall be filled with inert gas in an area known to be non-hazardous using the procedure specified by the manufacturer.

### **8.6 Safety devices**

Two automatic safety devices for Level of Protection “pxb” or Level of Protection “pyb” or one automatic safety device for Level of Protection “pzc” shall be provided to operate when the overpressure falls below the minimum value specified by the manufacturer. It shall be possible to check the correct operation of the devices when the equipment is in service. The automatic safety devices shall be capable of being reset only by the use of a tool or a key.

NOTE The purpose for which the automatic safety devices are used (that is, to disconnect power or to sound an alarm or otherwise ensure safety of the installation) is typically the responsibility of the user.

### **8.7 Equipment that may remain energized**

Electrical equipment within the pressurized enclosure that may be energized when type of protection “p” is not in operation shall have an EPL as shown in 7.15.

### **8.8 Overpressure**

The minimum overpressure shall be greater than the maximum pressure loss in normal service measured over a period not less than 100 times the time necessary for the cooling of enclosed components in accordance with the opening times requirements of IEC 60079-0, with a minimum of 1 h. The minimum level of overpressure shall not be less than 50 Pa above the external pressure under the most onerous conditions specified for normal service.

## 9 Supply of protective gas

### 9.1 Backup supply

If a backup supply of protective gas is required in the event of failure of the primary supply, then each supply shall be capable of maintaining, independently, the required level of pressure or rate of supply of protective gas. The two sources may share common ductwork or piping.

NOTE A backup supply can be advisable where it is necessary to maintain operation of the electrical equipment.

### 9.2 Independent supplies

When the enclosure of an ignition-capable product is protected by Level of Protection “pzc” pressurized enclosure and this enclosure is then located within a Level of Protection “pyb” pressurized enclosure, the protective gas supplies shall be independent.

### 9.3 Type of gas

The protective gas shall be non-flammable.

The Instructions shall specify the protective gas and any alternative permitted. Where other than air of normal instrument quality or nitrogen is specified, the protective gas should not, by reason of its chemical characteristics or the impurities that it may contain, reduce the effectiveness of the type of protection “p”, or adversely affect the satisfactory operation and integrity of the enclosed equipment.

When an inert gas is used, a risk of asphyxiation exists. Therefore a warning shall be affixed to the enclosure, (see 18.9.) Consideration should be given to providing a suitable means of purging the enclosure to remove the inert gas prior to the opening of doors or covers.

### 9.4 Temperature

The temperature of the protective gas shall not normally exceed 40 °C at the inlet of the enclosure. In special circumstances, a higher temperature may be permitted or a lower temperature may be required; in this case, the temperature shall be marked on the enclosure.

## 10 Pressurized equipment with an internal source of release

The release conditions, containment system design requirements, the appropriate pressurization techniques and the restrictions on ignition-capable equipment and internal hot surfaces are given in Clauses 11 to 15.

## 11 Release conditions

### 11.1 No release

11.1.1 There is no internal release when the containment system is infallible; see 12.2.

11.1.2 No internal release is deemed to exist when the flammable substances inside the containment system are in the gas or vapour phase when operating between the specified temperature limits and either:

- a) the gas mixture within the containment system is always below the LFL; or
- b) the minimum pressure specified for the pressurized enclosure is at least 50 Pa higher than the maximum pressure specified for the containment system and an automatic safety device is provided to operate if the pressure difference falls below 50 Pa.

NOTE The purpose(s) for which the signal from the automatic safety device is used (that is, to disconnect power or to sound an alarm or otherwise maintain the safety of the installation) is typically the responsibility of the user.

The certificate number shall include the "X" suffix in accordance with the marking requirements of IEC 60079-0 and the Specific Conditions of Use listed on the certificate shall detail the necessary information required by the user to ensure safe use.

### 11.2 Limited release of a gas or vapour

The rate of release of the flammable substance into the pressurized enclosure shall be predictable in all conditions of containment system failure; see 12.3. For the purposes of this standard, release of a liquefied gas is considered as release of a gas.

### 11.3 Limited release of a liquid

The rate of release of the flammable substance into the pressurized enclosure is limited as in 11.2, but the conversion of the liquid into a flammable vapour is not predictable. Consideration shall be given to the possible accumulation of liquid inside the pressurized enclosure and the consequences thereof.

If oxygen may be released from the liquid, the maximum flow rate of oxygen shall be predicted; see 13.2.2.

## 12 Design requirements for the containment system

### 12.1 General design requirements

The design and construction of the containment system, which will determine whether leakage is likely to occur or not, shall be based on the most onerous conditions of service specified by the manufacturer.

The containment system shall be either infallible or have a limited release upon failure. If the flammable substance is a liquid, there shall be no normal release (see Annex E) and the protective gas shall be inert.

NOTE The protective gas needs to be inert to prevent the evolved vapours from exceeding the capabilities of the diluting protective gas.

The manufacturer shall specify the maximum inlet pressure to the containment system.

Details of the design and construction of the containment system, the types and operating conditions of the flammable substance it may contain and the expected release rate or rates at given locations, shall be provided by the manufacturer in order for the containment system to be classified as an infallible containment system (12.2) or a containment system with limited release (12.3).

### 12.2 Infallible containment system

An infallible containment system shall be composed of metallic, ceramic or glass, pipes, tubes or vessels which have no moving joints. Joints shall be made by welding, brazing, glass to metal sealing, or by eutectic methods <sup>1)</sup>.

Low temperature solder alloys such as lead/tin composites are not acceptable.

<sup>1)</sup> A method of joining two or more components, normally metallic, employing a binary or ternary alloy system which solidifies at a constant temperature which is lower than the beginning of solidification of any of the components being joined.

The manufacturer should carefully consider damage to a potentially fragile containment system by adverse operating conditions. The Instructions should provide suitable guidance to reduce the risk of damage for those conditions agreed between manufacturer and user such as vibration, thermal shock and maintenance operations when doors or access covers of the pressurized enclosure are open.

### 12.3 Containment system with a limited release

The design of a containment system with limited release shall be such that the rate of release of the flammable substance is predictable in all conditions of containment system failure. The quantity of flammable substance released into the pressurized enclosure includes the quantity of flammable substance in the containment system and the flow of the flammable substance entering the containment system from the process. The flow shall be limited to a predictable rate by appropriate flow limiting devices fitted outside the pressurized enclosure.

However, if that part of the containment system from the entry point into the pressurized enclosure up to and including the inlet to the flow limiting device conforms to 12.2, the flow limiting device may be installed inside the pressurized enclosure, in which case the flow limiting device shall be permanently secured and shall have no movable parts.

The process flow into the containment system need not be limited if the maximum release rate from the containment system into the pressurized enclosure can be predicted. This condition can be met when:

- a) the containment system comprises connected parts which individually meet the requirements of 12.2 and the joints between the parts are so constructed that the maximum release rate can be predicted and the joints are permanently secured; or
- b) the containment system includes orifices, or nozzles, for the purpose of release in normal operation (for example, flames) but otherwise meets the requirements of 12.2.

If the flow limiting device is not included as part of the equipment, the certificate number shall include the "X" suffix in accordance with the marking requirements of IEC 60079-0 and the Specific Conditions of Use listed on the certificate shall detail the necessary information required by the user to ensure conformity with the requirements of this standard including the maximum pressure and flow of the flammable substance into the containment system.

Pressurized enclosures containing a flame shall be assessed as though the flame had been extinguished. The maximum quantity of the fuel/air mixture which supplies the flame shall be added to the quantity of release from the containment system.

Elastomeric seals, windows and other non-metallic parts of the containment system are permissible. Pipe threads, compression joints (for example, metallic compression fittings), and flanged joints are also permissible.

## 13 Protective gas and pressurizing techniques when there is an internal source of release

### 13.1 General

The choice of protective gas depends upon the probability, quantity and constituents of the release from the containment system. See Table 4 for tabulation of the permitted protective gas.

**Table 4 – Protective gas requirements for a pressurized enclosure with a containment system**

Internal release (see Annex E)				Continuous dilution		Leakage compensation	
Substance	Normal	Abnormal	Annex	UFL < 80 %	UFL > 80 %	UFL < 80 %	UFL > 80 %
Gas or liquid	None	None	E.2	Not applicable		Not applicable	
Gas	None	Limited	E.3	Air or inert	Air	Inert only	<no>
Gas	Limited	Limited	E.4	Air or inert	Air	<no>	<no>
Liquid	None	Limited	E.3	Inert only	<no>	Inert only	<no>
Liquid	Limited	Limited	E.4	<no>	<no>	<no>	<no>

<no> means pressurization technique not acceptable.

The design of the pressurized enclosure with a containment system and a limited release shall be such that no explosive gas atmosphere can be formed inside the pressurized enclosure at a potential ignition source, that is, outside the dilution area. Annex F provides examples of how internal partitions may be used to ensure potential ignition sources are outside the dilution area.

Where inert gas is used as the protective gas, the pressurized enclosure shall be marked in accordance with 18.9.

The applicable pressurizing techniques depend upon the release condition and on the constituents of the release as follows.

### 13.2 Pressurization with leakage compensation

#### 13.2.1 No release

The protective gas shall be air or inert gas.

#### 13.2.2 Limited release of a gas or liquid

The protective gas shall be inert gas.

The concentration of oxygen in the flammable substance shall not exceed 2 % (V/V).

There shall not be any normal release (see Annex E) of the flammable substance.

The UFL of the flammable substance shall not exceed 80 %.

NOTE It is difficult or impossible to protect with leakage compensation using inert gas when the flammable substance is capable of reacting with little or no oxygen present (that is to say it has a UFL greater than 80 %).

### 13.3 Pressurization with dilution

#### 13.3.1 General

If the flammable substance has a UFL exceeding 80 %, or if it has a concentration of oxygen exceeding 2 % (V/V), or if there is a normal release (see Annex E) of the flammable substance, then continuous flow shall be used to dilute the flammable substance.

#### 13.3.2 No release

The protective gas shall be air or inert gas.

### 13.3.3 Limited release of a gas or vapour

The flow rate of protective gas after purging shall be sufficient, under all conditions of containment system failure, to dilute the maximum release at a potential ignition source that is outside the dilution area, as follows:

- a) when the protective gas is air, the flammable substance in the release shall be diluted to a concentration not exceeding 25 % of the LFL;
- b) when the protective gas is inert, any oxygen in the release shall be diluted to a concentration not exceeding 2 % (V/V).

When the flammable substance released from the containment system has a UFL greater than 80 %, any release shall be diluted with air to a concentration not exceeding 25 % of the LFL.

NOTE It is necessary to dilute to 25 % of the LFL when the flammable substance is capable of reacting with little or no oxygen present, that is to say in cases a) UFL greater than 80 %.

### 13.3.4 Limited release of a liquid

The protective gas shall be inert and the provisions of 13.3.3 b) shall be complied with. There shall not be any normal release (see Annex E) of the flammable substance.

## 14 Ignition-capable equipment

Electrical equipment in the dilution area shall be protected by a Level of Protection listed in Table 5. Exceptions from this requirement are flames, igniters or other similar equipment intended to ignite a flame. The dilution area emanating from the flame shall not overlap any other dilution area.

**Table 5 – Equipment Protection Levels permitted within the dilution area based upon the Level of Protection of the pressurized enclosure**

Internal release is	Level of Protection “pxb”, Level of Protection “pyb”	Level of Protection “pzc”
abnormal	Ga or Gb	Ga, Gb or Gc
normal	Ga	Ga

Generally, any internal source of release should be near to the outlet and any ignition-capable equipment near to the inlet of the protective gas, to allow the shortest possible way for released flammable gas to leave the pressurized enclosure without passing ignition-capable equipment.

NOTE To avoid ignition from an ignition source within the containment system back into the plant, the use of a flame arrester can be necessary. Such measures are not covered by this standard.

## 15 Internal hot surfaces

An automatic safety device shall be provided if the pressurized enclosure contains any surface having a temperature which exceeds the ignition temperature of the flammable substance potentially released from the containment system. The action of the safety device following the operation of the safety device specified in 11.1.2 b) is shown in Table 3.

Additionally,

- a) if the protective gas is air, the release of the remaining flammable substance in the containment system shall not form a concentration greater than 50 % of the LFL in the vicinity of the hot surface(s); or

- b) if the protective gas is inert, the design and construction of the joints of the pressurized enclosure shall be such as to prevent significant mixing of external air with the internal inert gas (or internal flammable gas or vapour) during the cooling period. The ingress of external air shall not increase the concentration of oxygen to a value greater than 2.8% (V/V).

The pressurized enclosure shall be marked:

WARNING – DO NOT OPEN ANY DOOR OR COVER FOR xxx MINUTES AFTER REMOVING POWER

Where xxx is replaced with the value in minutes for the delay required.

This delay shall be the longer of the times taken for the hot surface to cool below the ignition temperature of the flammable substance released from the containment system or below the temperature class of the pressurized enclosure.

## 16 Type verification and tests

### 16.1 Determining the maximum overpressure rating

The maximum overpressure rating of the enclosure is the highest internal operating pressure attained by following the manufacturer's instructions.

NOTE The maximum overpressure generally occurs when purging the enclosure.

The measured internal pressure shall not exceed the maximum rated internal pressure for the enclosure if specified.

### 16.2 Maximum overpressure test

A pressure equal to 1,5 times the maximum overpressure determined in 16.1 or 200 Pa, whichever is the greater, shall be applied to the pressurized enclosure and, where they are an integral part of the enclosure, the associated ducts and their connecting parts.

The test pressure shall be applied for a period of 2 min ± 10 s.

The test is considered to be satisfactory if no permanent deformation occurs which would invalidate the type of protection.

### 16.3 Leakage test

#### 16.3.1 Other than static pressurization

The pressure in the pressurized enclosure shall be adjusted to the maximum overpressure specified by the manufacturer for normal service. With the outlet aperture closed, the leakage flow rate shall be measured at the inlet aperture.

Normal service does not include the overpressure required to open a vent in order to purge the enclosure at a higher flow rate.

The measured flow rate shall be not greater than the maximum leakage flow rate specified by the manufacturer.

#### 16.3.2 Static pressurization

The pressure in the pressurized enclosure shall be adjusted to the maximum overpressure that can occur in normal service. With the aperture(s) closed, the internal pressure shall be



monitored for a period of time, in accordance with 8.8. The pressure shall not drop below the minimum overpressure.

#### **16.4 Purging test for pressurized enclosures with no internal source of release and filling procedure test for static pressurization**

##### **16.4.1 General**

This test applies whether leakage compensation is used or not used (see 5.2.2.2 (continuous flow)).

##### **16.4.2 Pressurized enclosure where the protective gas is air**

The pressurized enclosure shall be prepared for test as described in Annex A. The pressurized enclosure shall be filled with the test gas to a concentration of not less than 70 % at any point. As soon as the pressurized enclosure is filled, the test gas supply shall be turned off and the air supply turned on at the minimum purging rate specified by the manufacturer. The time taken until there is no sample point where there is a test gas concentration in excess of that specified in A.2 shall be measured and noted as the purging time.

If a second test is required, the pressurized enclosure shall be filled with a second test gas, representing the other end of the density range, to a concentration of not less than 70 % at any point and the purging time for the second test shall be measured. The minimum purging duration specified by the manufacturer shall be not less than the measured purging time or the longer of the two measured purging times where two tests are carried out.

##### **16.4.3 Pressurized enclosure where the protective gas is inert**

The pressurized enclosure shall be prepared for test as described in Annex A. The enclosure shall be filled initially with air at normal atmospheric pressure. The enclosure shall then be purged with the inert gas specified by the manufacturer.

The time taken until there is no sample point where there is an oxygen concentration exceeding that specified in A.3 shall be measured and noted as the purging time.

The minimum purging duration specified by the manufacturer shall be not less than the measured purging time.

##### **16.4.4 Pressurized enclosure where the protective gas may be either air or an inert gas with a density equal to air $\pm 10$ %**

Where air and inert gas are permitted as alternative protective gases with the same purging time, the purging time shall be measured by the method specified in 16.4.2

##### **16.4.5 Filling procedure test for a pressurized enclosure protected by static pressurization**

In the case of static pressurization, the enclosure shall be filled initially with air at normal atmospheric pressure. The equipment shall then be filled with inert gas in accordance with the manufacturer's specifications. It shall then be verified that there is no sample point where there is an oxygen concentration exceeding 1 % (V/V), referred to atmospheric conditions.

#### **16.5 Purging and dilution tests for a pressurized enclosure with an internal source of release**

##### **16.5.1 Test gas**

The choice of test gas or gases shall take account of both the external gases and the internally released flammable substance.



### **16.5.2 Pressurized enclosure where the flammable substance has less than 2 % (V/V) oxygen and the protective gas is inert**

#### **16.5.2.1 Purging test**

The test shall be carried out using the test procedure specified in 16.4.3. The minimum purge flow rate shall not be less than the maximum release rate from the containment system.

The minimum purging time specified by the manufacturer shall be not less than 1,5 times the measured purging time.

To make allowance for oxygen that could be released from the containment system during purging, the purging time confirmed in the test shall be increased by 50 %.

#### **16.5.2.2 Dilution test**

A dilution test is not required because the flammable substance does not contain more than 2 % (V/V) oxygen.

### **16.5.3 Pressurized enclosure with pressurization by continuous flow, containment system with less than 21 % (V/V) oxygen and the protective gas is inert**

#### **16.5.3.1 Purging test**

The enclosure shall be filled with air. Air shall also be injected into the enclosure through the containment system at a flow rate corresponding to the maximum release rate in a manner representing the most onerous conditions of release, taking into account the position, number and nature of the releases and their proximity to potentially ignition-capable equipment that is outside the dilution area.

The supply of protective gas shall then be turned on at the minimum purging flow rate specified by the manufacturer.

The time taken until there is no sample point where there is an oxygen concentration exceeding that specified in A.3 shall be recorded as the measured purging time.

The minimum purging duration specified by the manufacturer shall be not less than the measured purging time.

#### **16.5.3.2 Dilution test**

Immediately after the purging test specified in 16.5.3.1, the supply of the protective gas shall be adjusted to the minimum flow rate specified by the manufacturer, the oxygen flow rate from the containment system being maintained at that specified in 16.5.3.1.

The oxygen concentration measured over a period of time not less than 30 min shall not exceed the concentration as specified in A.3.

A quantity of air containing an equivalent quantity of oxygen to that within the containment system shall then be released into the pressurized enclosure from the containment system together with a release of air in accordance with 12.3.

During the period of release, the concentration of oxygen in the vicinity of potentially ignition-capable equipment, that is outside the dilution area, shall not exceed 1,5 times the oxygen concentration specified in A.3 and shall, in a time not greater than 30 min, be reduced below the specified concentration.

NOTE This test is used to simulate a bulk release equating to a catastrophic failure of the containment system.

#### **16.5.4 Pressurized enclosure where the flammable substance is not a liquid, pressurization by continuous flow and the protective gas is air**

##### **16.5.4.1 Purging test**

The test shall be carried out using the test procedure specified in 16.4.2.

In addition, during the test, the test gas shall be injected into the pressurized enclosure through the containment system at the maximum release rate, in a manner representing the most onerous conditions of release, taking into account the position, number and nature of the releases and their proximity to potentially ignition-capable equipment that is outside the dilution area.

The time taken until there is no sample point where there is a test gas concentration exceeding that specified in A.2 shall be measured.

If a second test is required, the test shall be repeated using the second test gas and the purging time recorded as the measured purging time.

The minimum purging duration specified by the manufacturer shall be not less than the measured purging time or the longer of the two measured purging times where two tests are carried out.

##### **16.5.4.2 Dilution test**

Immediately after the purging test specified in 16.5.4.1, the supply of protective gas shall be adjusted, if necessary, to the minimum dilution flow rate specified by the manufacturer, the test gas flow rate from the containment system being maintained at that specified in 16.5.3.1.

The test gas concentration measured during a time period of not less than 30 min shall not exceed that specified in A.2.

A quantity of test gas equivalent to the volume of flammable gas within the containment system shall then be released into the pressurized enclosure from the containment system together with a flow of test gas equivalent to the maximum release of flammable gas in accordance with 12.3.

During the period of release, the concentration of a test gas in the vicinity of potentially ignition-capable equipment, that is outside the dilution area, shall not exceed twice the value specified in A.2 and shall be reduced below the specified value within 30 min.

If a second test is required, the test shall be repeated using the second test gas.

NOTE This test is used to simulate a bulk release equating to a catastrophic failure of the containment system.

#### **16.6 Verification of minimum overpressure**

A test shall be made to verify that the pressurization system is capable of operating and maintaining an overpressure complying with 7.12 under normal service conditions.

The pressure in the enclosure shall be measured at points where leakage is likely to occur, and especially where the lowest pressure will occur.

Protective gas shall be supplied to the pressurized enclosure at the minimum overpressure, and if necessary, at the minimum flow rate specified by the manufacturer.

For rotating electrical machines, the tests shall be carried out both with the machine stopped and with it running at its maximum rated speed.

## 16.7 Tests for an infallible containment system

### 16.7.1 Overpressure test

A test pressure of at least 5 times the maximum operating pressure specified for normal service with a minimum of 1 000 Pa shall be applied to the containment system for a period of  $2 \text{ min} \pm 10 \text{ s}$ . The containment system shall be tested under the most onerous conditions of rated temperature.

The increase of the test pressure should achieve the maximum pressure within 5 s.

The test is considered to be satisfactory if no permanent deformation occurs and the test specified in 16.7.2 is passed.

### 16.7.2 Infallibility test

The containment system shall be flushed and pressurized with pure helium (95,0 % V/V or higher) to a pressure equal to the maximum operating pressure of the containment system. A helium leak detector shall then be used to check for leaks. The test is considered satisfactory if the leak detector does not indicate any leaks.

NOTE Leaks are indicated by a reading higher than the ambient room reading.

## 16.8 Overpressure test for a containment system with a limited release

NOTE This test is carried out on a containment system which has a limited release during normal operation.

A test pressure of at least 1,5 times the maximum internal overpressure specified for normal service, with a minimum of 200 Pa, shall be applied to the containment system and maintained for a time of  $2 \text{ min} \pm 10 \text{ s}$ . The test is considered to be satisfactory if no permanent deformation occurs.

## 17 Routine tests

### 17.1 Functional test

The performance of safety devices provided with the pressurized enclosure shall be verified.

### 17.2 Leakage test

The leakage of protection gas shall be tested as specified in 16.3.

### 17.3 Tests for an infallible containment system

An infallible containment system shall be tested as specified in 16.7. However, for liquid systems, it is adequate to check for liquid leaks during the overpressure test in place of the helium leak test.

### 17.4 Test for a containment system with a limited release

The containment system shall be tested as specified in 16.8.

## 18 Marking

### 18.1 General

In addition to the requirements of IEC 60079-0, the marking shall include the following. Where warning markings are required by this standard, the text following the word "WARNING" may

be replaced by technically equivalent text. Multiple warnings may be combined into one equivalent warning.

### 18.2 Identifying as pressurized

The pressurized enclosure shall be marked "WARNING – PRESSURIZED ENCLOSURE".

### 18.3 Supplementary marking

The following supplementary information shall also be marked as appropriate:

- a) the Level of Protection "pxb", "pyb", or "pzc"; or
- b) minimum quantity of protective gas required to purge the enclosure specified by
  - minimum purging flow rate of protective gas; and
  - minimum purging duration; and
  - minimum additional purging duration per unit volume of additional ducting (where appropriate);

NOTE 1 It is typically the responsibility of the user to increase the quantity of protective gas to ensure purging of the ducts.

For Level of Protection "pzc" and Level of Protection "pyb", the minimum pressure may be used in place of the flow rate if the pressure is a positive indication of the correct flow (see 7.8 c).

- c) type of protective gas if other than air;
- d) minimum and maximum overpressure;
- e) minimum flow rate of protective gas;
- f) minimum and maximum supply pressure to the pressurization system;
- g) the maximum leakage rate from the pressurized enclosure;
- h) a special temperature or range of temperatures for the protective gas at the inlet to the pressurized enclosure when specified by the manufacturer;
- i) the point or points at which the pressure is to be monitored unless this is indicated in the relevant documentation.

### 18.4 Internal source of release

Pressurized enclosures with a containment system shall additionally be marked with the following, as appropriate:

- a) the maximum inlet pressure to the containment system;
- b) the maximum flow rate into the containment system;
- c) a restriction that the flammable substance oxygen concentration shall not exceed 2 %;
- d) a restriction that the flammable substance shall not have a UFL higher than 80 %.

### 18.5 Static pressurization

Pressurized enclosures protected by static pressurization shall be marked:

WARNING – THIS ENCLOSURE IS PROTECTED BY STATIC PRESSURIZATION. THIS ENCLOSURE SHALL BE FILLED ONLY IN A NON-HAZARDOUS AREA ACCORDING TO THE MANUFACTURER'S INSTRUCTIONS

### 18.6 Pressurization systems

A pressurization system with a separate certificate is marked as associated pressurization equipment.

When a pressurization system with a separate certificate is marked for installation in a hazardous area, the symbol “[p]” shall be included in the “Ex marking”. When a pressurization with a separate certificate is marked for installation only in a non-hazardous area, the “Ex marking” shall be “[Ex p]”.

NOTE Markings “[p]” and “[Ex p]” do not appear in IEC 60079-0, Ed. 6 or earlier.

### 18.7 Warnings required in other clauses

Table 6 – Text of warning markings

Clause or subclause	Recommended warning (similar wording is permitted)
5.3.6	WARNING – DO NOT OPEN WHEN AN EXPLOSIVE ATMOSPHERE IS PRESENT
7.8 c)	WARNING – POWER SHALL NOT BE RESTORED AFTER ENCLOSURE HAS BEEN OPENED UNTIL ENCLOSURE HAS BEEN PURGED FOR ___ MINUTES AT A FLOW RATE OF ____
7.9	WARNING – POWER SHALL NOT BE RESTORED AFTER THE ENCLOSURE HAS BEEN OPENED UNTIL COMBUSTIBLE DUST ACCUMULATIONS WITHIN THE ENCLOSURE HAVE BEEN REMOVED
7.11 d)	WARNING – PROTECTIVE GAS SUPPLY VALVE – FOLLOW INSTRUCTIONS BEFORE CLOSING
15	WARNING – DO NOT OPEN ANY DOOR OR COVER FOR xxx MINUTES AFTER REMOVING POWER
G.7.1	WARNING – BATTERIES ARE LOCATED INSIDE THIS ENCLOSURE. DO NOT OPEN WHEN AN EXPLOSIVE ATMOSPHERE IS PRESENT
G.7.2	WARNING – THIS PRESSURIZED ENCLOSURE CONTAINS A BATTERY WHICH REMAINS CONNECTED AFTER THE EXTERNAL POWER HAS BEEN ISOLATED. CONSIDERATION SHOULD BE GIVEN TO THE REMOVAL OF THE BATTERY IF THE ENCLOSURE IS TO REMAIN UNPROTECTED BY EX P FOR A SIGNIFICANT TIME
G.7.3	WARNING – BATTERIES IN THIS PRESSURIZED ENCLOSURE REQUIRE ROUTINE MAINTENANCE. SEE INSTRUCTIONS
H.3.1	WARNING – BATTERIES ARE LOCATED INSIDE THIS ENCLOSURE. DO NOT OPEN WHEN AN EXPLOSIVE ATMOSPHERE IS PRESENT
H.3.2	WARNING – THIS PRESSURIZED ENCLOSURE CONTAINS A BATTERY WHICH REMAINS CONNECTED AFTER THE EXTERNAL POWER HAS BEEN ISOLATED. CONSIDERATION SHOULD BE GIVEN TO THE REMOVAL OF THE BATTERY IF THE ENCLOSURE IS TO REMAIN UNPROTECTED BY EX P FOR A SIGNIFICANT TIME
H.3.3	WARNING – BATTERIES IN THIS PRESSURIZED ENCLOSURE REQUIRE ROUTINE MAINTENANCE. SEE INSTRUCTIONS

### 18.8 Overpressure limited by user

When instructions require the user to limit the pressure, the maximum operating pressure shall be marked on the enclosure. The instructions shall contain either of the following:

- requirements for the user to install a protective gas supply that will not exceed the maximum operating pressure of the enclosure under single-fault conditions. The fault should be self-revealing. Protection can be either with a redundant regulator or with an external pressure relief valve that is capable of handling the maximum flow rate; or
- requirements for the user to use only a blower system and not compressed air for the protective gas supply.

Compliance is checked by inspection of the instructions and markings.

### 18.9 Inert gas

Pressurized enclosures using inert gas as the protective gas shall be marked as follows:

WARNING – THIS ENCLOSURE CONTAINS INERT GAS AND MAY BE AN ASPHYXIATION HAZARD. THIS ENCLOSURE ALSO CONTAINS A FLAMMABLE SUBSTANCE THAT MAY BE WITHIN THE FLAMMABLE LIMITS WHEN EXPOSED TO AIR.

## 19 Instructions

In addition to the instructions required by IEC 60079-0,

- the protective gas and any alternative permitted shall be specified;
- instructions for Group III equipment shall identify the need to remove the combustible dust in an appropriate manner before restoring power.

NOTE It is the responsibility of the user to determine what is an appropriate manner for removing the combustible dust.

Annex D provides recommendations with respect to pressurization.

<http://www.china-gauges.com/>

## Annex A (normative)

### Purging and dilution tests

#### A.1 General

The internal atmosphere of the pressurized enclosure shall be tested at different points where it is considered that the test gas is most likely to persist and in the vicinity of potentially ignition-capable equipment, that is outside the normal dilution area.

The gas concentration at the test points shall be analysed or measured throughout the period of the test(s). For example, the pressurized enclosure may be fitted with a number of small-bore tubes, the open ends of which shall be located inside the pressurized enclosure at the sampling points.

If the test consists of taking samples, the quantities taken should not significantly influence the test.

If necessary, apertures in the pressurized enclosure may be closed to enable the pressurized enclosure to be filled with the specified test gas, provided they are re-opened for the purging and dilution tests.

Where air is used as the protective gas the test method shall be as follows:

- when required for specific applications, tests may be carried out for specific flammable gases and vapours. In this case the flammable gases shall be specified and test gas(es) chosen having densities within  $\pm 10\%$  of the heaviest and lightest gas specified;
- in the case of a single specified gas, a single test shall be carried out with a test gas having a density within  $\pm 10\%$  of the specified gas;
- when it is required to cover all flammable gases, two tests shall be carried out. One test shall be made to cover lighter-than-air gases using helium as the test gas. The second test shall be made to cover heavier-than-air gases using either argon or carbon dioxide as the test gas.

Test gases should be non-flammable and non-toxic.

#### A.2 Criteria for compliance where the protective gas is air

The concentration of test gas at the sample points after purging and applicable dilution shall not exceed the following values:

- where test(s) were conducted for specific flammable gases, a value equivalent to 25 % of the most onerous LFL;
- where one specific flammable gas is covered, a value equivalent to 25 % of its LFL;
- where all flammable gases are covered, 1 % for the helium test and 0,25 % for the argon or carbon dioxide test.

NOTE These values correspond approximately to 25 % of the LFL for light and heavy flammable gases respectively.

#### A.3 Criteria for compliance where the protective gas is inert

Where the protective gas is inert, the concentration of oxygen after purging and applicable dilution shall not exceed 2 % (V/V).

**Annex B**  
(informative)

**Examples of functional sequence diagram**

Table B.1 gives an example of information to be provided by the manufacturer for a simple control system for a pressurized enclosure with leakage compensation.

**Table B.1 – Truth table of a leakage-compensation purge control system**

S0	S1	S2	S3	MOP	XOP	PFLO	PTIM
1	0	0	0	0	1	0	1
1	0	0	0	0	0	0	1
1	0	0	0	1	1	1	0
1	0	0	0	1	1	0	1
1	0	0	0	1	1	1	1
1	0	0	0	0	1	1	1
1	0	0	0	0	0	1	1
1	0	0	0	0	0	1	1
1	0	0	0	1	1	0	0
1	0	0	0	0	1	0	0
1	0	0	0	0	0	0	0
1	0	0	0	0	0	1	0
1	0	0	0	0	1	1	0
0	1	0	0	1	0	0	0
0	0	1	0	1	0	1	0
0	0	0	1	1	0	0	1
0	0	0	1	1	0	1	1

Figure B.1 demonstrates a state diagram of a leakage-compensation purge control system.

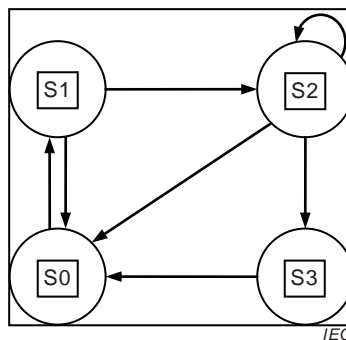

**Figure B.1 – State diagram of a leakage-compensation purge control system**



LEAKAGE-COMPENSATION LOGICAL DEFINITIONS

Exceeds maximum overpressure = [XOP]

Overpressure > 50 Pa (25 Pa for Level of Protection “pzc”) = [MOP]

Purge flow > minimum = [PFLO]

Purge time incomplete =  $\overline{[PTIM]}$

Purge time complete = [PTIM]

Initial state = S0

$[MOP] \ \& \ \overline{[XOP]} \ \& \ \overline{[PFLO]} \ \& \ \overline{[PTIM]}$  = S1 Minimum conditions to start purge

$[MOP] \ \& \ \overline{[XOP]} \ \& \ [PFLO] \ \& \ \overline{[PTIM]}$  = S2 Purging

$[MOP] \ \& \ \overline{[XOP]} \ \& \ [PTIM]$  = S3 Purging complete, power connected

Each state of the system is defined in response to the inputs of the monitoring devices. The states are unique. Transitions between states are only allowed along paths defined by the arrows and in the direction of the arrows. The logical conditions for the occupation of each state are uniquely defined by Boolean logical expressions. All possible combinations of input conditions are shown in the table. Other systems with more monitoring devices can be described by this method provided each operational state is uniquely defined by its inputs.

**Annex C**  
(informative)

**Examples of the changes in pressure in ducts and enclosures**

Figures C.1 to C.4 show examples of the changes in pressure in ducts and enclosures.

NOTE In the figures, examples are shown where the overpressure is maintained by a fan. This can however also be provided by other means, for example, by feeding air from compressed air cylinders, compressors, etc. In such cases, there would be different pressure drops up to the enclosure entrance.

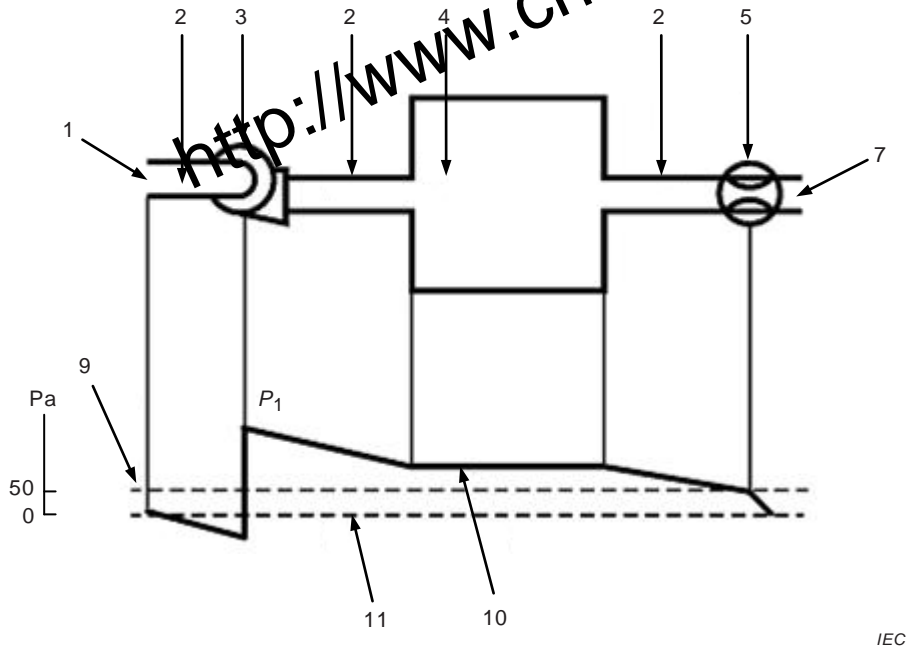

**Key**

- $P_1$  Pressure of the protective gas (determined by the flow resistance through the ducting, the parts within the enclosure and in certain cases through a choke)
- |   |                              |
|---|------------------------------|
| 1 Protective gas inlet (in a non-hazardous area)      | 7 Protective gas outlet      |
| 2 Ducting   | 8 (Not used on this diagram) |
| 3 Fan   | 9 Overpressure               |
| 4 Enclosure   | 10 Internal pressure         |
| 5 Choke (where required to maintain the overpressure) | 11 External pressure         |
| 6 (Not used on this diagram)                          |                              |

**Figure C.1 a) – Protective gas outlet without a spark and particle barrier**

IEC

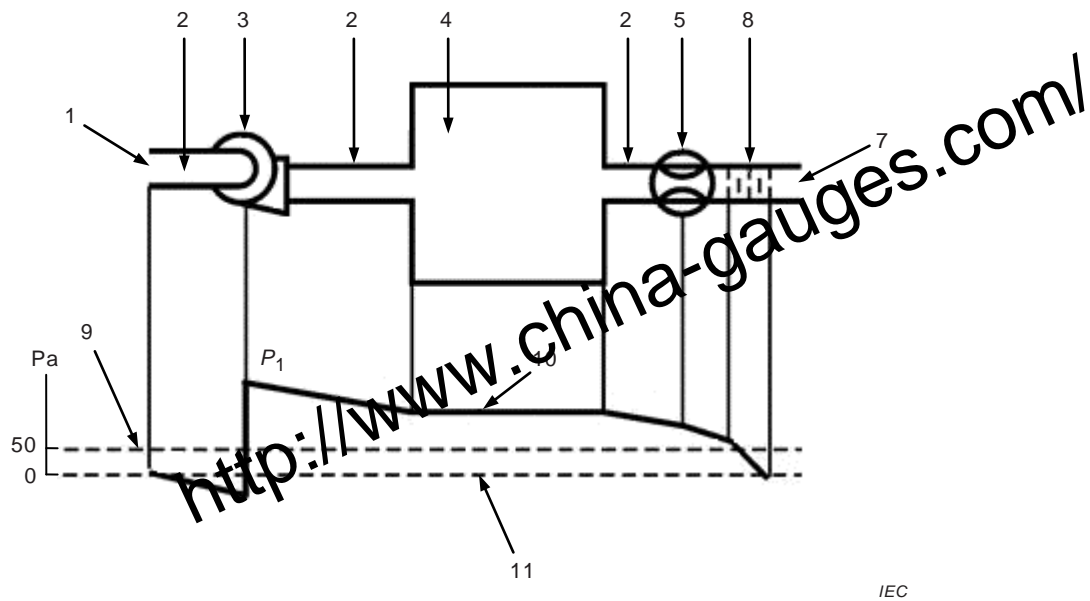

IEC

**Key**

$P_1$  Pressure of the protective gas (determined by the flow resistance through the ducting, the parts within the enclosure and in certain cases through a choke and spark and particle barrier)

- |   |                              |
|---|------------------------------|
| 1 Protective gas inlet (in a non-hazardous area)      | 7 Protective gas outlet      |
| 2 Ducting   | 8 Spark and particle barrier |
| 3 Fan   | 9 Overpressure               |
| 4 Enclosure   | 10 Internal pressure         |
| 5 Choke (where required to maintain the overpressure) | 11 External pressure         |
| 6 (Not used on this diagram)                          |                              |

**Figure C.1 b) – Protective gas outlet with a spark and particle barrier**

**Figure C.1 – Protective gas outlet**

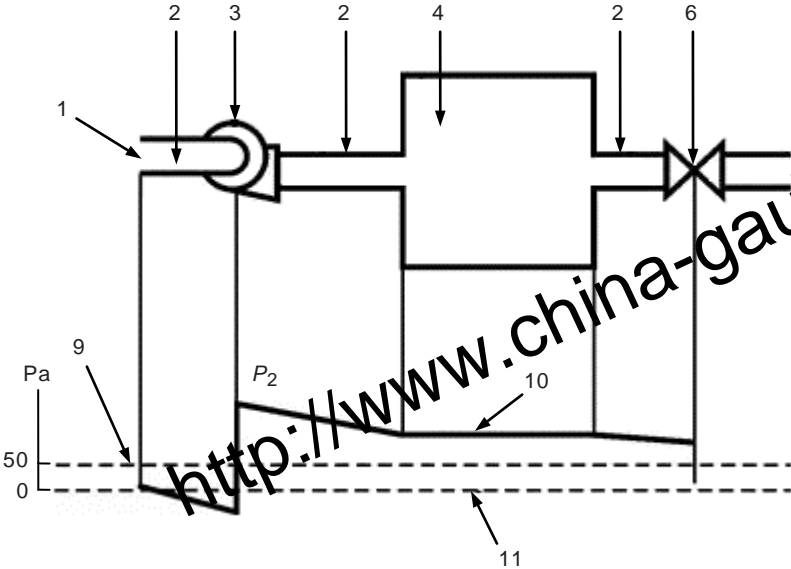

IEC

**Key**

$P_2$  Pressure of the protective gas (almost constant)

- 1 Protective gas inlet (in a non-hazardous area)
- 2 Ducting
- 3 Fan
- 4 Enclosure
- 5 (Not used on this diagram)
- 6 Outlet valve
- 7 Protective gas outlet
- 8 (Not used on this diagram)
- 9 Overpressure
- 10 Internal pressure
- 11 External pressure

**Figure C.2 – Pressurized enclosures with leakage compensation, enclosures without moving parts**

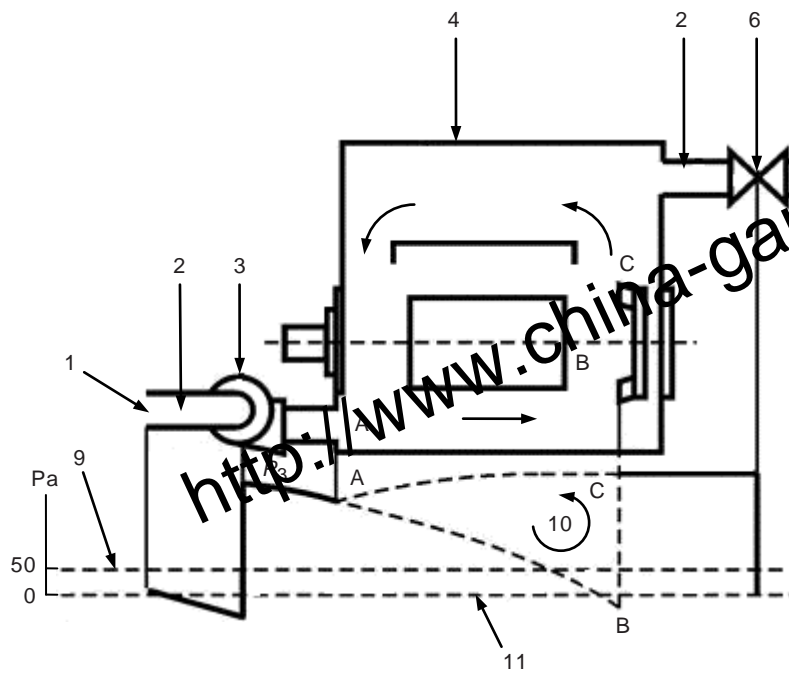

IEC

**Key**

$P_3$  Pressure of the protective gas (determined by the flow resistance of the internal parts, and influenced between A, B and C by the internal cooling fan)

- |  |                              |
|--|------------------------------|
| 1 Protective gas inlet (in a non-hazardous area) | 7 Protective gas outlet      |
| 2 Ducting  | 8 (Not used on this diagram) |
| 3 Fan  | 9 Overpressure               |
| 4 Enclosure                                      | 10 Internal pressure         |
| 5 (Not used on this diagram)                     | 11 External pressure         |
| 6 Outlet valve                                   |                              |

**Figure C.3 – Pressurized enclosures with leakage compensation, rotating electrical machine with an internal cooling fan**

Pressure at every point where leakage can occur is above the minimum of 50 Pa for Level of Protection “pxb”.

Care should be taken in the application of pressurization to motors having an internally enclosed cooling circuit in which circulation is assisted by an internal fan, since the effect of such fans may be to produce a negative pressure in parts of the casing with consequent risk of ingress of the external atmosphere. Any proposal to pressurize an internally ventilated motor should be submitted to the manufacturer of the motor.

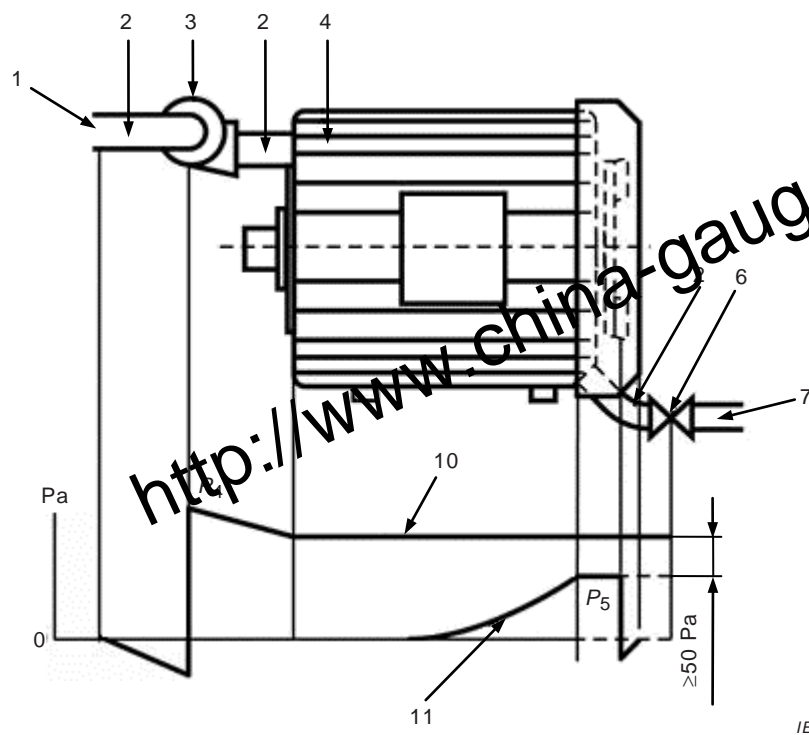

IEC

**Key**

$P_4$  Pressure of protective gas (determined by the flow resistance of the internal parts and by the uppermost value of pressure of the external air)

$P_5$  Pressure of the external air, caused by the external cooling fan

- |  |                              |
|--|------------------------------|
| 1 Protective gas inlet (in a non-hazardous area) | 7 Protective gas outlet      |
| 2 Ducting  | 8 (Not used on this diagram) |
| 3 Fan  | 9 (Not used on this diagram) |
| 4 Enclosure                                      | 10 Internal pressure         |
| 5 (Not used on this diagram)                     | 11 External pressure         |
| 6 Outlet valve                                   |                              |

**Figure C.4 – Pressurized enclosure with a leakage compensation, rotating electrical machine with an external cooling fan**

## Annex D (informative)

### Information to be provided to the user

#### D.1 General

It is essential for safety that information about proper installation of the pressurization system be provided to the user.

Specific issues that the manufacturer should address as appropriate are as follows in Clause D.2 to Clause D.6 inclusive.

#### D.2 Ducting of protective gas

##### D.2.1 Location of inlet

Except for cylinder-supplied gases and some Group I applications, the point at which the protective gas enters the supply duct(s) should be situated in a non-hazardous area.

Consideration should be given to minimizing the migration of flammable gases or combustible dusts from the hazardous area to the non-hazardous area upon loss of pressurization.

For Group I applications where the protective gas enters the supply ducts from a hazardous area, the following precautions should be taken:

- a) two independent firedamp detectors should be fitted at the discharge side of the fan or compressor, each arranged to automatically disconnect the electricity supply to the pressurized enclosure if the concentration of firedamp exceeds 10 % of the lower explosive limit;
- b) the time taken to achieve automatic disconnection should not be greater than one half the transit time for the protective gas to flow from the detection point to the pressurized enclosure;
- c) in the event of automatic disconnection, the pressurized enclosure should be repurged before the electricity supply is restored. The purging time should not start until the firedamp concentration at the source of protective gas falls below 10 % of the lower explosive limit.

##### D.2.2 Ducting between pressurized enclosure and inlet

The intake ducting to a compressor should not normally pass through a hazardous area.

If the compressor intake line passes through a hazardous area, it should be constructed of non-combustible material and protected against mechanical damage and corrosion.

Adequate precautions should be taken to ensure that the ducting is free from leaks in case the internal pressure is below that of the external atmosphere (see Annex C). Additional protective measures, for example, combustible gas detectors, should be considered to ensure that the ducting is free of flammable concentrations of gas or vapour.

##### D.2.3 Outlets for protective gas

Ducts for exhausting the protective gas should preferably have their outlets in an area which would, apart from the area in close proximity to the outlets, be non-hazardous, unless spark and particle barriers have been provided by the manufacturer or added by the user.

#### **D.2.4 Additional purge time to account for ducting**

The purge duration should be increased by the time necessary to purge the free volume of those associated ducts which are not part of the equipment by at least five times their volume at the minimum flow rate specified by the manufacturer.

#### **D.2.5 Temperature of protective gas at the inlet**

If necessary, measures should be taken to avoid condensation and refilling.

#### **D.3 Power for protective gas supply**

The electrical power for the protective gas supply (blower, compressor, etc.) should be either taken from a separate power source or taken from the supply side of the electrical isolator, (e.g. disconnect) for the pressurized enclosure.

#### **D.4 Static pressurization**

If the overpressure falls below the minimum specified, the pressurized enclosure should be removed to a non-hazardous area before refilling.

#### **D.5 Enclosures with a containment system**

The maximum pressure and flow of the flammable substance into the containment system should not exceed the ratings specified by the manufacturer.

Additional precautions may be necessary if an explosive mixture may possibly form due to air penetration into the containment system.

Adequate precautions should be taken to prevent adverse operating conditions that may damage the containment system. The description documents should explain these conditions such as vibration, thermal shock and maintenance operations when doors or access covers of the pressurized enclosure are open.

A flow switch may be required to stop the flow of the flammable substance, for example, if it could be ignited by a hot internal surface and the positive internal pressure is relied upon to prevent release from the containment system.

Additional precautions may be necessary if the abnormal release may adversely affect the external area classification.

Consideration should be given to the possible formation of a flammable mixture due to the possibility of air penetration into the containment system and the resulting additional precautions that may be necessary.

#### **D.6 Enclosure maximum overpressure**

The user should limit the pressure as specified by the manufacturer.



## **Annex E** (normative)

### **Classification of the type of release within enclosures**

#### **E.1 General**

The consequences of a release of flammable substances within an enclosure are more severe than a similar release in free air. A temporary leak inside an enclosure will build up flammable substances which will remain inside the enclosure for a long time even after the leak stops. Because of this, it is necessary to assign greater importance to “normal release” and “abnormal release” than for a release in open air.

In all cases, devices shall be fitted to limit the flow of flammable substances from the containment system into the pressurized enclosure. Only limited releases are permitted.

#### **E.2 No normal release, no abnormal release**

The containment system meets the design requirements in 12.2 and the test requirements in 16.7 for infallible containment.

#### **E.3 No normal release, limited abnormal release**

A containment system which does not meet the requirements for infallible containment and comprises metallic pipes, tubes or elements such as Bourdon tubes, bellows or spirals, with joints not subject to disconnection during routine maintenance and made with pipe threads, welding, eutectic methods, or metallic compression fittings shall be considered to have no normal release but limited abnormal release.

Rotating or sliding joints, flanged joints, elastomeric seals and non-metallic flexible tubing do not satisfy this criterion.

#### **E.4 Limited normal release**

Systems which cannot meet the requirements for “no normal release” shall be considered to have a limited normal release. This includes containment systems with joints subject to routine maintenance. Such joints shall be clearly identified.

Containment systems whose construction comprises non-metallic pipes, tubes, or elements such as Bourdon tubes, bellows, diaphragms, spirals, elastomeric seals, rotating or sliding joints shall be considered to be a source of release in normal operation.

Enclosures having a flame in normal operation shall be assessed with the flame extinguished. It shall be assumed that extinguishing of the flame is a normal occurrence and that the equipment shall be classified as having a normal release unless devices are fitted to stop the flow of flammable gas or vapour automatically upon flame extinction.

**Annex F**  
(informative)

**Examples for the use of the dilution area concept**

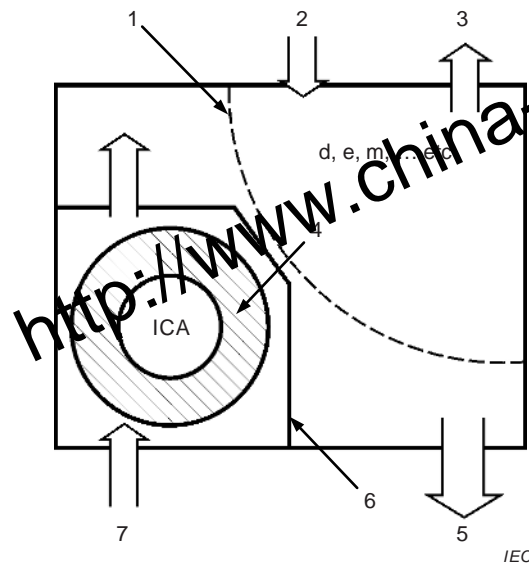

**Key**

- |   |                                   |   |                          |
|---|-----------------------------------|---|--------------------------|
| 1 | Nominal boundary of dilution area | 5 | Purge outlet             |
| 2 | Inlet of flammable material       | 6 | Partition to enclose ICE |
| 3 | Outlet of flammable material      | 7 | Purge inlet              |
| 4 | Area of dilution testing          |   |                          |

**Figure F.1 – Diagram showing the use of the dilution area concept to simplify the purge and dilution test requirements**

By enclosing ignition-capable equipment (shown as ICA in Figures F.1 to F.3) within an inner enclosure or through the use of partitions, it can be demonstrated by a simple test that the ICE does not lie within a dilution area. It is not necessary to determine the extent of the dilution area, merely to determine that the dilution area does not extend to the ICE.

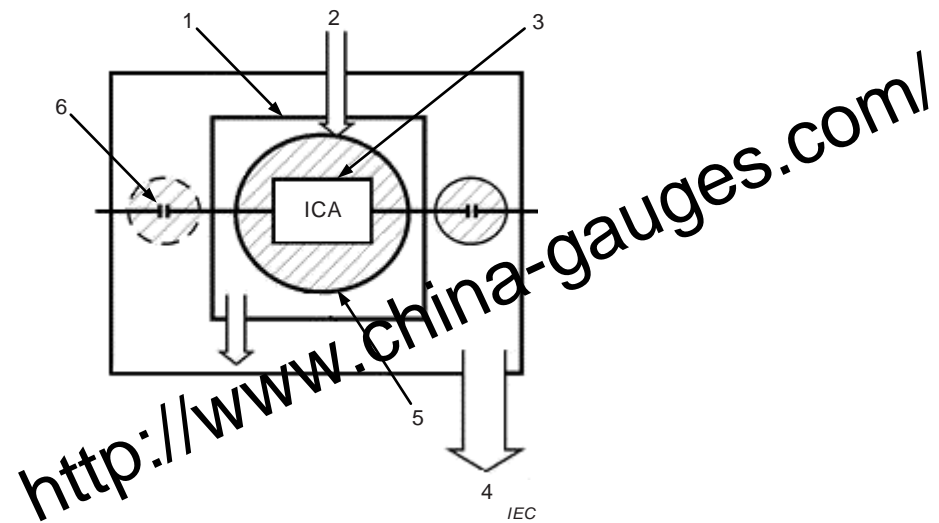
**Key**

- |  |  |
|--|--|
| 1 Internal partition                     | 4 Purge outlet   |
| 2 Purge inlet                            | 5 Location of ICE  |
| 3 Infallible parts of containment system | 6 Potential source of release with nominal dilution area |

**Figure F.2 – Diagram showing the use of the infallible containment system concept to simplify the purging and dilution requirements around ICE**

Since those parts of the containment system lying within the internal partition meet the requirements for infallible containment, the ICE (shown as ICA in Figures F.1 to F.3) cannot be within a dilution area.

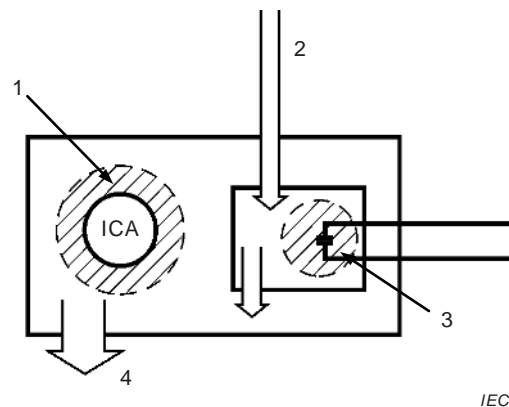
**Key**

- |                              |  |
|------------------------------|--|
| 1 Area of dilution testing   | 3 Potential source of release with nominal dilution area |
| 2 Purge inlet with inert gas | 4 Purge outlet   |

**Figure F.3 – Diagram showing the use of internal partitions around the potential source of release to simplify the purging and dilution requirements around ICE located outside the partitions**

Since the dilution area is contained within the internal partition, the ICE (shown as ICA in Figures F.1 to F.3) is not within a dilution area.

## Annex G (normative)

### Internal Cells and Batteries for Level of Protection “pxb” and Level of Protection “pyb”

#### G.1 General Requirements

##### G.1.1 General

When the protected equipment incorporates batteries, suitable precautions shall be taken in the design of the equipment to prevent the production of explosive gas, sparks or hot spots.

##### G.1.2 Accepted Electrochemical Systems

Only those cells listed in IEC 60079-0 for which an IEC cell standard exists shall be used in pressurized enclosures.

##### G.1.3 Secondary cells and secondary batteries

Secondary cells and secondary batteries are permitted if:

- the individual cells are sealed cells (either sealed gas-tight cell or sealed valve-regulated cell); or
- the battery volume does not exceed 1 % of the pressurized enclosure internal free volume.

Where the pressurized enclosure contains more than one independent battery, each with its own charging system, only the most onerous case of gas release from one independent battery shall be considered.

##### G.1.4 Mechanical Protection

Live exposed parts of cells, batteries and their associated protective components, which are located in the pressurized enclosure, shall be provided with protection to at least IP30, even while the pressurized enclosure access door(s) or cover(s) are open. Where cells are encapsulated, care shall be taken to ensure that any pressure relief facilities are not obstructed. The vent size shall be sufficiently large to prevent dangerous pressurisation of the encapsulated assembly at the most onerous predictable release rate from the battery. A minimum of one vent for each cell is required.

The encapsulation of cells and batteries shall allow for possible expansion of the cells during charging.

For the purposes of this standard the terms "encapsulate" and "encapsulation" do not imply conformity to IEC 60079-18.

The physical characteristic of vents will depend upon the type and capacity of the battery arrangements. The effects of ageing on battery capacity and therefore on the rate of gas evolution from the battery should also be considered.

Cells, batteries and their associated protective components shall be securely mounted.

## G.2 Electrical Protection by energy limiting circuits.

### G.2.1 Assessing as energy limited

The intent of this section is to allow circuits that can be assessed using the principles of IEC 60079-11 as a guideline.

### G.2.2 Protective Components

Except for inherently safe batteries (see G.5), protective components such as a resistor and/or a fuse shall be provided to establish an energy limited circuit to guard against withdrawal of current from a battery greater than the current for which safety has been assessed.

Protective Components shall conform to the following requirements. The manufacturer's technical literature is sufficient to verify conformity with these requirements without further testing.

- Diodes used to prevent charging or reverse charging of primary cells shall not be exposed to a reverse applied voltage exceeding two thirds of their rated Peak Inverse Voltage (PIV), (or Repetitive Peak Reverse Voltage ( $V_{rrm}$ ) if specified).
- These diodes shall be capable of withstanding a reverse voltage of 400 Vdc with a reverse leakage current of < 10 uA at the most extreme conditions of temperature (taking account of a single fault within the associate circuit).
- The maximum forward current (taking account of a single fault within the associated circuit) of diodes whose purpose is to prevent the charging of a primary cell shall be limited e.g. by a fuse or resistor, to a value not exceeding 50 % of the manufacturer's rated peak forward current.
- Fuses shall conform to IEC 60127 (any part) as follows:

The voltage to be used when assessing a fuse depends upon the maximum voltage to which it can be subjected plus tolerances. In the case of a battery supplied voltage, the voltage to be considered shall be the nominal voltage defined in the appropriate IEC standard for the electrochemical system used.

Where a fuse is used to protect a battery, 1,7 In (nominal current rating of fuse) shall be assumed to flow continuously. The fuse time-current characteristics shall ensure that the transient ratings of protected components are not exceeded.

- Current limiting resistors shall be one of the following types and may be used at up to two thirds of the manufacturer's rating:
  - film type,
  - wire wound type with protection to prevent unwinding of the wire in case of breakage or,
  - printed resistors as used in hybrid and similar circuits covered by a coating conforming to IEC 60079-11 or encapsulated in accordance with IEC 60079-11.

A Current Limiting Resistor shall be considered as failing only to an open circuit.

- Other components shall conform to the appropriate requirements of IEC 60079-11.

### G.2.3 Preventing excessive gas pressure

Means to prevent the build-up of excessive gas pressure shall be provided:

- a) under reverse charge, e.g. shunt diodes fitted across each cell of a battery;
- b) under excessive discharge rates, e.g. a fuse fitted in series with the battery;
- c) for secondary batteries, under excessive charge rates, e.g. a charger designed to limit the charging conditions to those recommended by the manufacturer.

### G.3 Additional requirements for Primary batteries

#### G.3.1 Prevention of reverse charging.

No additional protection need be fitted to prevent the release of electrolytic gas by polarity reversal, or reverse charging of a cell by other cells in the same battery is required if:

- a capacity of 1,5 Ah or less (at a 1 h discharge rate); and
- a volume less than 1 % of the free volume of the enclosure;

or if the battery manufacturer confirms that the cells are electro-chemically balanced, and at the end of discharge the internal resistance of an individual cell will exceed 25 k $\Omega$ .

These relaxations should not be interpreted as allowing the release of electrolytic gas from such cells.

If a primary battery contains 3 or more cells in series, one or more components, shall be fitted to prevent gas generation within an expired cell by reverse charging (see figure G.1).

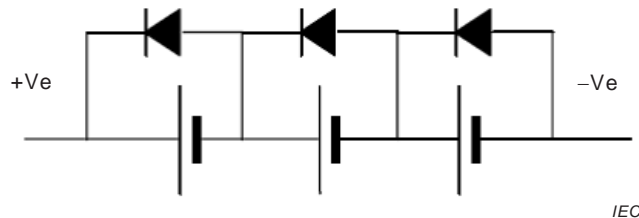

Figure G.1 – Reverse charging protection

For this protective arrangement to be effective, the forward voltage drop across each diode used to prevent reverse charging of a cell shall not exceed the safe reverse charge voltage of that cell. Silicon diodes are considered suitable to meet this requirement.

#### G.3.2 Prevention of accidental charging of primary batteries

Where there is more than one battery or another voltage source in the equipment, and there is the possibility of interconnection, protective components such as blocking diodes shall be provided to prevent charging currents passing into primary batteries.

At least two serially connected devices shall be provided such as to limit the charging of primary batteries, even under single fault conditions, to a level not exceeding 10  $\mu$ A or to 2/3rds of that specified by the battery manufacturer, whichever is the lower (e.g.2 diodes or a diode and a resistor (see Figure G.2).

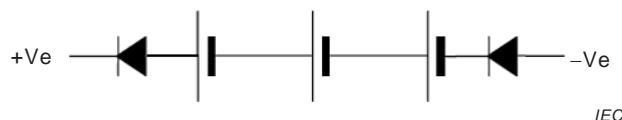

Figure G.2 – Accidental charging protection

The battery should be connected between the protective components to reduce the risk of a single fault causing both protective components to be short circuited.

## G.4 Additional requirements for secondary batteries

### G.4.1 Charging of secondary batteries inside the pressurized housing

Where batteries are to be charged whilst inside the pressurized enclosure, the charging conditions shall be fully specified and protective components shall be fitted to ensure that these conditions are not exceeded.

Where batteries are used having a capacity of 1,5 Ah or less, and a volume less than 1 % of the free volume of the enclosure, no additional protective component(s) needs to be fitted to the battery to prevent the release of electrolytic gas by recharging currents.

These relaxations should not be interpreted as allowing the release of electrolytic gas from such cells.

NOTE The above effectively limits the use of cells (or batteries) not fitted with a protective component, to those types commonly known as "button type cells" used, for example to retain memory on programmable electronic circuits.

Where batteries are to be removed from the pressurized enclosure for charging, the manufacturer's requirements for correct charging apply.

Where the consequences of deep discharging may, during subsequent charging, result in either the increased release of electrolytic gas and/or internal mechanical damage, a device or devices shall be provided to prevent deep discharging.

Suitable precautions shall be taken to prevent incorrect assembly (e.g. plugs and sockets which are polarized or that are clearly marked to indicate correct assembly).

Where plugs and sockets are used, provision shall be made to open the circuit safely before plugs are disconnected.

The position of the battery within the pressurized enclosure shall be chosen with due regard to the location of ignition-capable equipment and to allow for the free diffusion of the released gases throughout the enclosure. Ignition-capable equipment shall not be located in an area subject to the gas released from the battery.

## G.5 Specific requirements for Inherently Safe (IhS) cells and batteries

An IhS battery is a primary battery in which the following conditions are met:

- the internal resistance of the battery limits the short-circuit current from the battery to a value not exceeding that tabulated in Permitted short-circuit current corresponding to the voltage and the equipment group tabulated in IEC 60079-11 based upon the maximum open circuit voltage of the battery and
- the maximum temperature of the external surface of the battery does not exceed the maximum surface temperature for the stated Temperature Class for the equipment, referred to the local ambient temperature when the battery is short-circuited by a conductor of negligible resistance compared with the internal resistance of the battery. The resistance of the short-circuit is considered to be negligible when it is not greater than one-tenth of the internal resistance of the battery.

It is not necessary to consider faults within an IhS cell, except when more than two cells are connected to form a battery in which case reverse charging shall be prevented.

IhS batteries may be formed by the interconnection of IhS cells if the internal resistance of the battery limits the maximum value of the short-circuit current to a value not exceeding the value tabulated in Permitted short-circuit current corresponding to the voltage and the

equipment group tabulated in IEC 60079-11 based upon the maximum open circuit voltage of the battery.

The nature of the circuit to which the IHS battery may be connected is specified in G.6.

To facilitate the correct replacement of Inherently Safe batteries the essential parameters shall be marked adjacent to the battery and in the instructions, (e.g. Type, Nominal voltage and minimum internal resistance etc.)

## **G.6 Equipment located inside a pressurized enclosure connected to a battery which is also located inside the pressurized enclosure and not disconnected in the event of loss of pressurization**

### **G.6.1 General**

For the purpose of evaluation and test of the circuit connected to the battery the voltage to be considered is the Maximum Open Circuit Voltage.

The Temperature Class of the equipment shall take into account the surface area of individual components comprising the equipment connected to the battery. The method of assessment shall be either by test, or by the use of small component temperature evaluation in IEC 60079-0.

### **G.6.2 Circuit Isolation**

For the purpose of this clause, equipment is considered to be connected to the battery unless the battery is connected to the equipment only after purging has been completed and provision is made for the disconnection of the battery on pressure or flow failure and the disconnection or isolation meets the following requirements:

- it is disconnected by suitably rated contacts; or
- it is isolated by a suitably rated opto-isolating device; or
- it is isolated by a suitably rated double wound transformer capable of withstanding an insulation test between windings of 5 times the battery maximum open circuit voltage with a minimum of 500 Vac RMS for at least 60 seconds;
- and the creepage distance and clearance between the battery and the isolated or disconnected components and associated circuits is as specified in the creepage and clearance table in IEC 60079-11 using the ia or ib columns.

### **G.6.3 Intrinsically safe battery or inherently safe battery used with "Ex" equipment**

If the battery is protected by Intrinsic Safety to IEC 60079-11 or is inherently safe and the connected equipment is protected by one of the types of protection listed in IEC 60079-0 or is assessed as simple apparatus as defined in IEC 60079-11, there are no additional requirements.

### **G.6.4 Intrinsically Safe or Inherently Safe battery with non-"Ex" equipment.**

When an intrinsically safe or an inherently safe battery located inside the pressurized enclosure is intended to be connected to non-"Ex" equipment before purging has been completed, and/or intended to remain connected to the equipment during the absence of pressure (and flow if specified), the following additional requirements apply to the connected equipment:

Either:

- a) The following conditions shall be satisfied:



- maximum open circuit voltage of the battery and associated circuits does not exceed 6 V;
- the short circuit current from the battery shall not exceed 2 A. This may be achieved by the internal resistance of the battery alone or be limited to this value by the addition of an external current limiting resistor mounted as close as possible to the battery and conforming to the requirements of G.2.1;
- the total aggregate circuit capacitance, including tolerances, does not exceed 1000  $\mu\text{F}$ ;
- the total aggregate circuit inductance, including tolerances, does not exceed the value for  $L$  given by the following formula:

where:

$L$  is the permitted inductance in  $\mu\text{H}$

$I$  is the available short circuit current in A

$e$  is the ignition energy for a given Equipment Group in  $\mu\text{J}$

Equipment Group	Ignition energy
IIC	40 $\mu\text{J}$
IIB	160 $\mu\text{J}$
IIA	320 $\mu\text{J}$
I	525 $\mu\text{J}$

or

- b) the pressurised enclosure shall be marked in accordance with G.7 and the following conditions shall be satisfied:

- the maximum open circuit voltage of the battery and associated circuits does not exceed 6 V;
- the short circuit current shall be limited to 2 A;
- the effective capacitance remaining connected to the battery, as determined by examination of the circuit does not exceed 1 000  $\mu\text{F}$ ;

Protective components, e.g. resistors, associated with the capacitance and conforming to the requirements for similar components in G.2.1 may be taken into account in determining the effective capacitance by the use IEC 60079-11 with a factor of safety of 1,0;

- the effective inductance remaining connected to the battery, as determined by examination of the circuit does not exceed the values given for  $L$  shown above.

Protective components, e.g. resistors, associated with the inductance and conforming to the requirements for similar components in G.2.1 may be taken into account in determining the effective inductance by the use of IEC 60079-11 with a factor of safety of 1,0.

or

- c) where the sources voltage is greater than 6 V or the short circuit current is greater than 2 A, the connected equipment shall be assessed according IEC 60079-11 category 'ib';

or

- d) a cell embedded within a solid state electronic component (e.g. a Lithium cell within an integrated circuit) is permitted if the following criteria are met:

- the cell shall be Inherently Safe; and
- no external voltage shall be detectable; and

- the internal capacitance and inductance of the solid state electronic component as declared by the manufacturer shall not exceed the values given in a)) above.

Since the cell voltage is not externally detectable the short circuit test in conformity with the requirements of G.5 may be carried out by assessment.

## **G.7 Supplementary marking and constructional requirements for pressurized enclosures containing one or more cells or batteries**

### **G.7.1 General**

Doors and covers of pressurized enclosure may only be openable by the use of a tool or key.

Enclosures shall be marked as follows, or equivalent:

"WARNING – BATTERIES ARE LOCATED INSIDE THIS ENCLOSURE. DO NOT OPEN WHEN AN EXPLOSIVE ATMOSPHERE IS PRESENT".

### **G.7.2 Battery removal warning**

Where required by G.6.4 b) the enclosure shall be marked with the following or equivalent:

WARNING – This pressurized enclosure contains a battery which remains connected after the external power has been isolated. Consideration should be given to the safe removal of the battery if the enclosure is to remain unprotected by Ex p for a significant time.

### **G.7.3 Batteries requiring routine maintenance**

The enclosure shall be marked:

"WARNING – Batteries in this Pressurized Enclosure require routine maintenance. See instructions".

## **G.8 Type tests**

### **G.8.1 Voltage**

For temperature testing purposes the voltage to be used is the battery nominal voltage.

### **G.8.2 Short circuit test for an Inherently Safe Cell or Battery**

A new cell or battery shall have a short circuit applied and the following shall be monitored:

- current flowing in the circuit, and
- the temperature of the outer surface of the cell or battery to which any external explosive atmosphere will have access when the pressurized enclosure door is open.

The maximum current shall not exceed the value given in G.5.

The maximum temperature shall not exceed the temperature class of the equipment.

The cell or battery shall not distort, explode, or emit smoke.

### **G.8.3 Full load test for other than Inherently safe batteries**

A new primary battery, or a fully charged secondary battery, shall be connected to the load it will supply in normal service. The case temperature shall not exceed the temperature class of the equipment or the maximum temperature permitted by the manufacturer of the battery, whichever is lower.

## Annex H (normative)

### Internal Cells and Batteries for Level of Protection “pzc”

#### H.1 General Requirements

##### H.1.1 General

When the protected equipment incorporates batteries, suitable precautions shall be taken in the design of the equipment to prevent the production of explosive gas, sparks or hot spots.

##### H.1.2 Accepted Electrochemical Systems

Only those cells listed in IEC 60079-0 for which an IEC cell standard exists shall be used in pressurized enclosures.

##### H.1.3 Secondary cells and secondary batteries

Secondary cells and secondary batteries are permitted if:

- The individual cells are sealed cells (either sealed gas-tight cell or sealed valve-regulated cell); or
- The battery volume does not exceed 1 % of the pressurized enclosure internal free volume.

Where the pressurized enclosure contains more than one independent battery, each with its own charging system, only the most onerous case of gas release from one independent battery shall be considered.

##### H.1.4 Mechanical Protection

Where cells are encapsulated, care shall be taken to ensure that any pressure relief facilities are not obstructed. The vent size shall be sufficiently large to prevent dangerous pressurisation of the encapsulated assembly at the most onerous predictable release rate from the battery. A minimum of one vent for each cell is required.

The encapsulation of cells and batteries shall allow for possible expansion of the cells during charging.

For the purposes of this standard the terms "encapsulate" and "encapsulation" do not imply conformity to IEC 60079-18.

The physical characteristic of vents will depend upon the type and capacity of the battery arrangements. The effects of ageing on battery capacity and therefore on the rate of gas evolution from the battery should also be considered.

Cells, batteries and their associated protective components shall be securely mounted.

## **H.2 Equipment located inside a pressurized enclosure connected to a battery which is also located inside the pressurized enclosure and is not disconnected when power is removed from the enclosure.**

Equipment that is not disconnected shall not have any make/break components unless the circuit can be assessed as non-ignition-capable using IEC 60079-15 or IEC 60079-11 for Level of Protection "ic".

## **H.3 Supplementary marking and constructional requirements for pressurized enclosures containing one or more cells or batteries**

### **H.3.1 General**

Doors and covers of pressurized enclosure providing access to the cells or batteries may only be opened by the use of a tool or key.

Enclosures shall be marked as follows, or equivalent:

"Warning – Batteries are located inside this enclosure. Do not open when an explosive atmosphere IS present".

### **H.3.2 Battery removal warning**

Where the cell or battery is not disconnected when pressurization is not present, the enclosure shall be marked with the following or equivalent:

Warning – This pressurized enclosure contains a battery which remains connected after the external power has been isolated. Consideration should be given to the removal of the battery if the enclosure is to remain unprotected by Ex p for a significant time.

### **H.3.3 Batteries requiring routine maintenance**

The enclosure shall be marked:

"WARNING – Batteries in this Pressurized Enclosure require routine maintenance. See instructions."

## Bibliography

- IEC 60050-151, *International Electrotechnical Vocabulary – Chapter 151: Electrical and magnetic devices*
- IEC 60050-426, *International Electrotechnical Vocabulary – Chapter 426: Equipment for explosive atmospheres*
- IEC 60051 (all parts), *Direct acting indicating analogue electrical measuring instruments and their accessories*
- IEC 60079-1, *Explosive atmospheres – Part 1: Equipment protection by flameproof enclosures “d”*
- IEC 60079-5, *Explosive atmospheres – Part 5: Equipment protection by powder filling “q”*
- IEC 60079-6, *Explosive atmospheres – Part 6: Equipment protection by oil-immersion “o”*
- IEC 60079-7, *Explosive atmospheres – Part 7: Equipment protection by increased safety “e”*
- IEC 60079-13, *Explosive atmospheres – Part 13: Equipment protection by pressurized room “p”*
- IEC 60079-18, *Explosive atmospheres – Part 18: Equipment protection by encapsulation “m”*
- IEC 60079-20-1, *Explosive atmospheres – Part 20-1: Material characteristics for gas and vapour classification – Test methods and data*
- IEC 60079-26, *Explosive atmospheres – Part 26: Equipment with equipment protection level (EPL) Ga*
- IEC 60079-28, *Explosive atmospheres – Part 28: Protection of equipment and transmission systems using optical radiation*
- IEC 61511 (all parts) *Functional safety – Safety instrumented systems for the process industry sector*
-

<http://www.china-gauges.com/>

<http://www.china-gauges.com/>

# British Standards Institution (BSI)

BSI is the national body responsible for preparing British Standards and other standards-related publications, information and services.

BSI is incorporated by Royal Charter. British Standards and other standardization products are published by BSI Standards Limited.

## About us

We bring together business, industry, government, consumers, innovators and others to shape their combined experience and expertise into standards-based solutions.

The knowledge embodied in our standards has been carefully assembled in a dependable format and refined through our open consultation process. Organizations of all sizes and across all sectors choose standards to help them achieve their goals.

## Information on standards

We can provide you with the knowledge that your organization needs to succeed. Find out more about British Standards by visiting our website at [bsigroup.com/standards](http://bsigroup.com/standards) or contacting our Customer Services team or Knowledge Centre.

## Buying standards

You can buy and download PDF versions of BSI publications, including British and adopted European and international standards, through our website at [bsigroup.com/shop](http://bsigroup.com/shop), where hard copies can also be purchased.

If you need international and foreign standards from other Standards Development Organizations, hard copies can be ordered from our Customer Services team.

## Subscriptions

Our range of subscription services are designed to make using standards easier for you. For further information on our subscription products go to [bsigroup.com/subscriptions](http://bsigroup.com/subscriptions).

With **British Standards Online (BSOL)** you'll have instant access to over 55,000 British and adopted European and international standards from your desktop. It's available 24/7 and is refreshed daily so you'll always be up to date.

You can keep in touch with standards developments and receive substantial discounts on the purchase price of standards, both in single copy and subscription format, by becoming a **BSI Subscribing Member**.

**PLUS** is an updating service exclusive to BSI Subscribing Members. You will automatically receive the latest hard copy of your standards when they're revised or replaced.

To find out more about becoming a BSI Subscribing Member and the benefits of membership, please visit [bsigroup.com/shop](http://bsigroup.com/shop).

With a **Multi-User Network Licence (MUNL)** you are able to host standards publications on your intranet. Licences can cover as few or as many users as you wish. With updates supplied as soon as they're available, you can be sure your documentation is current. For further information, email [bsmusales@bsigroup.com](mailto:bsmusales@bsigroup.com).

## BSI Group Headquarters

389 Chiswick High Road London W4 4AL UK

## Revisions

Our British Standards and other publications are updated by amendment or revision.

We continually improve the quality of our products and services to benefit your business. If you find an inaccuracy or ambiguity within a British Standard or other BSI publication please inform the Knowledge Centre.

## Copyright

All the data, software and documentation set out in all British Standards and other BSI publications are the property of and copyrighted by BSI, or some person or entity that owns copyright in the information used (such as the international standardization bodies) and has formally licensed such information to BSI for commercial publication and use. Except as permitted under the Copyright, Designs and Patents Act 1988 no extract may be reproduced, stored in a retrieval system or transmitted in any form or by any means – electronic, photocopying, recording or otherwise – without prior written permission from BSI. Details and advice can be obtained from the Copyright & Licensing Department.

## Useful Contacts:

### Customer Services

**Tel:** +44 845 086 9001

**Email (orders):** [orders@bsigroup.com](mailto:orders@bsigroup.com)

**Email (enquiries):** [cservices@bsigroup.com](mailto:cservices@bsigroup.com)

### Subscriptions

**Tel:** +44 845 086 9001

**Email:** [subscriptions@bsigroup.com](mailto:subscriptions@bsigroup.com)

### Knowledge Centre

**Tel:** +44 20 8996 7004

**Email:** [knowledgecentre@bsigroup.com](mailto:knowledgecentre@bsigroup.com)

### Copyright & Licensing

**Tel:** +44 20 8996 7070

**Email:** [copyright@bsigroup.com](mailto:copyright@bsigroup.com)