

BS EN 60079-15:2010



BSI Standards Publication

<http://www.china-gauges.com/>

Explosive atmospheres

Part 15: Equipment protection by type of protection "n"

bsi.

...making excellence a habit.™

National foreword

This British Standard is the UK implementation of EN 60079-15:2010. It is identical to IEC 60079-15:2010. It supersedes BS EN 60079-15:2005 which is withdrawn.

The UK Committee GEL/31 does not endorse Annex ZY in its current form and a revision is currently under way between the Joint Working Group of CEN TC305 and CLC TC31. An amendment Annex ZY will become available at some time in the future.

The UK participation in its preparation was entrusted to Technical Committee GEL/31/14, Types of Protection 'e' and 'n'.

A list of organizations represented on this committee can be obtained on request to its secretary.

This publication does not purport to include all the necessary provisions of a contract. Users are responsible for its correct application.

© BSI 2010

ISBN 978 0 580 59523 3

ICS 29.260.20

Compliance with a British Standard cannot confer immunity from legal obligations.

This British Standard was published under the authority of the Standards Policy and Strategy Committee on 30 September 2010.

Amendments/corrigenda issued since publication

Date	Text affected
------	---------------

English version

Explosive atmospheres
Part 15: Equipment protection by type of protection "n"
(IEC 60079-15:2010)

Atmosphères explosives
Partie 15: Protection du matériel
par mode de protection "n"
(CEI 60079-15:2010)

Explosionsfähige Atmosphäre -
Teil 15: Geräteschutz
durch Zündschutzart "n"
(IEC 60079-15:2010)

This European Standard was approved by CENELEC on 2010-05-01. CENELEC members are bound to comply with the CEN/CENELEC Internal Regulations which stipulate the conditions for giving this European Standard the status of a national standard without any alteration.

Up-to-date lists and bibliographical references concerning such national standards may be obtained on application to the Central Secretariat or to any CENELEC member.

This European Standard exists in three official versions (English, French, German). A version in any other language made by translation under the responsibility of a CENELEC member into its own language and notified to the Central Secretariat has the same status as the official versions.

CENELEC members are the national electrotechnical committees of Austria, Belgium, Bulgaria, Croatia, Cyprus, the Czech Republic, Denmark, Estonia, Finland, France, Germany, Greece, Hungary, Iceland, Ireland, Italy, Latvia, Lithuania, Luxembourg, Malta, the Netherlands, Norway, Poland, Portugal, Romania, Slovakia, Slovenia, Spain, Sweden, Switzerland and the United Kingdom.

CENELEC

European Committee for Electrotechnical Standardization
Comité Européen de Normalisation Electrotechnique
Europäisches Komitee für Elektrotechnische Normung

Management Centre: Avenue Marnix 17, B - 1000 Brussels

Foreword

The text of document 31/833/FDIS, future edition 4 of IEC 60079-15, prepared by IEC TC 31, Equipment for explosive atmospheres, was submitted to the IEC-CENELEC parallel vote and was approved by CENELEC as EN 60079-15 on 2010-05-01.

This European Standard supersedes EN 60079-15:2005.

The significant technical changes with respect to EN 60079-15:2005 are as follows:

- addition of equipment protection levels;
- removal of the requirements for energy-limited “nL” and associated energy limited apparatus “[nL]”;
- removal of the requirements for encapsulated devices “nC”;
- requirements for electrical connections expanded and clarified;
- requirements for luminaire ballasts expanded and clarified;
- requirements for evaluation and testing of motor rotors clarified;
- 15 kV limit for equipment protection by type of protection “n” added;
- spacing requirement for voltages above 10 kV modified;
- requirements for restricted breathing enclosures modified;
- modification to requirements for motor rotors and stators;
- addition of Annex A (informative);
- undated references to IEC 60079-0 included.

This standard is to be used in conjunction with EN 60079-0.

Attention is drawn to the possibility that some of the elements of this document may be the subject of patent rights. CEN and CENELEC shall not be held responsible for identifying any or all such patent rights.

The following dates were fixed:

- latest date by which the EN has to be implemented
at national level by publication of an identical
national standard or by endorsement (dop) 2011-02-01
- latest date by which the national standards conflicting
with the EN have to be withdrawn (dow) 2013-05-01

This European Standard has been prepared under a mandate given to CENELEC by the European Commission and the European Free Trade Association and covers essential requirements of EC Directive 94/9/EC. See Annex ZZ.

Annexes ZA, ZY and ZZ have been added by CENELEC.

Endorsement notice

The text of the International Standard IEC 60079-15:2010 was approved by CENELEC as a European Standard without any modification.

In the official version, for Bibliography, the following notes have to be added for the standards indicated:

IEC 60034-5	NOTE	Harmonized as EN 60034-5.
IEC/TS 60034-17	NOTE	Harmonized as CLC/TS 60034-17.
IEC 60068-2-6	NOTE	Harmonized as EN 60068-2-6.
IEC 60079-7:2006	NOTE	Harmonized as EN 60079-7:2006 (not modified).
IEC 60079-17	NOTE	Harmonized as EN 60079-17.
IEC 60079-18	NOTE	Harmonized as EN 60079-18.
IEC 60079-29-2	NOTE	Harmonized as EN 60079-29-2.
IEC 60297 series	NOTE	Harmonized in EN 60297 series (not modified).

<http://www.china-gauges.com/>

Annex ZA
(normative)

**Normative references to international publications
with their corresponding European publications**

The following referenced documents are indispensable for the application of this document. For dated references, only the edition cited applies. For undated references, the latest edition of the referenced document (including any amendments) applies.

NOTE When an international publication has been modified by common modifications, indicated by (mod), the relevant EN/HD applies.

<u>Publication</u>	<u>Year</u>	<u>Title</u>	<u>EN/HD</u>	<u>Year</u>
IEC 60034	Series	Rotating electrical machines	EN 60034	Series
IEC 60034-1	-	Rotating electrical machines - Part 1: Rating and performance	EN 60034-1	-
IEC/TS 60034-25	-	Rotating electrical machines - Part 25: Guidance for the design and performance of a.c. motors specifically designed for converter supply	CLC/TS 60034-25	-
IEC 60061	Series	Lamp caps and holders together with gauges for the control of interchangeability and safety	-	-
IEC 60061-1	-	Lamp caps and holders together with gauges for the control of interchangeability and safety - Part 1: Lamp caps	EN 60061-1	-
IEC 60068-2-27	2008	Environmental testing - Part 2-27: Tests - Test Ea and guidance: Shock	EN 60068-2-27	2009
IEC 60079-0	2007	Explosive atmospheres - Part 0: Equipment - General requirements	EN 60079-0	2009
IEC 60079-1	-	Explosive atmospheres - Part 1: Equipment protection by flameproof enclosures "d"	EN 60079-1	-
IEC 60079-11	-	Explosive atmospheres - Part 11: Equipment protection by intrinsic safety "i"	EN 60079-11	-
IEC 60112	-	Method for the determination of the proof and the comparative tracking indices of solid insulating materials	EN 60112	-
IEC 60155	-	Glow-starters for fluorescent lamps	EN 60155	-
IEC 60228	-	Conductors of insulated cables	EN 60228	-
IEC 60238	-	Edison screw lampholders	EN 60238	-
IEC 60269-3	-	Low-voltage fuses - Part 3: Supplementary requirements for fuses for use by unskilled persons (fuses mainly for household or similar applications) - Examples of standardized systems of fuses A to F	HD 60269-3	-
IEC 60400	-	Lampholders for tubular fluorescent lamps and starterholders	EN 60400	-

<u>Publication</u>	<u>Year</u>	<u>Title</u>	<u>EN/HD</u>	<u>Year</u>
IEC 60529	-	Degrees of protection provided by enclosures (IP Code)	EN 60529	-
IEC 60598	Series	Luminaires	EN 60598	Series
IEC 60598-1 (mod)	2008	Luminaires -	EN 60598-1	2008
-	-	Part 1: General requirements and tests	+ A11	2009
IEC 60598-2	Series	Luminaires - Part 2: Particular requirements	EN 60598-2	Series
IEC 60664-1	-	Insulation coordination for equipment within low-voltage systems - Part 1: Principles, requirements and tests	EN 60664-1	-
IEC 60927	-	Auxiliaries for lamps - Starting devices (other than glow starters) - Performance requirements	EN 60927	-
IEC 60947-7-1	-	Low-voltage switchgear and controlgear - Part 7-1: Ancillary equipment - Terminal blocks for copper conductors	EN 60947-7-1	-
IEC 60947-7-2	-	Low-voltage switchgear and controlgear - Part 7-2: Ancillary equipment - Protective conductor terminal blocks for copper conductors	EN 60947-7-2	-
IEC 60998-2-4	-	Connecting devices for low voltage circuits for household and similar purposes - Part 2-4: Particular requirements for twist-on connecting devices	EN 60998-2-4	-
IEC 60999-1	-	Connecting devices - Electrical copper conductors - Safety requirements for screw-type and screwless-type clamping units - Part 1: General requirements and particular requirements for clamping units for conductors from 0,2 mm ² up to 35 mm ² (included)	EN 60999-1	-
IEC 60999-2	-	Connecting devices - Electrical copper conductors - Safety requirements for screw-type and screwless-type clamping units - Part 2: Particular requirements for clamping units for conductors above 35 mm ² up to 300 mm ² (included)	EN 60999-2	-
IEC 61048	-	Auxiliaries for lamps - Capacitors for use in tubular fluorescent and other discharge lamp circuits - General and safety requirements	EN 61048	-
IEC 61184	-	Bayonet lampholders	EN 61184	-
IEC 61195	-	Double-capped fluorescent lamps - Safety specifications	EN 61195	-
IEC 61347-1 (mod)	2007	Lamp controlgear - Part 1: General and safety requirements	EN 61347-1	2008
IEC 61347-2-1	-	Lamp controlgear - Part 2-1: Particular requirements for starting devices (other than glow starters)	EN 61347-2-1	-
IEC 61347-2-2	-	Lamp controlgear - Part 2-2: Particular requirements for d.c. or a.c. supplied electronic step-down convertors for filament lamps	EN 61347-2-2	-
IEC 61347-2-3	-	Lamp controlgear - Part 2-3: Particular requirements for a.c. supplied electronic ballasts for fluorescent lamps	EN 61347-2-3	-

<u>Publication</u>	<u>Year</u>	<u>Title</u>	<u>EN/HD</u>	<u>Year</u>
IEC 61347-2-4	-	Lamp controlgear - Part 2-4: Particular requirements for d.c. supplied electronic ballasts for general lighting	EN 61347-2-4	-
IEC 61347-2-7	-	Lamp controlgear - Part 2-7: Particular requirements for d.c. supplied electronic ballasts for emergency lighting	EN 61347-2-7	-
IEC 61347-2-8	-	Lamp controlgear - Part 2-8: Particular requirements for ballasts for fluorescent lamps	EN 61347-2-8	-
IEC 61347-2-9	-	Lamp controlgear - Part 2-9: Particular requirements for ballasts for discharge lamps (excluding fluorescent lamps)	EN 61347-2-9	-

<http://www.china-gauges.com/>

Annex ZY
(informative)

Significant changes between this European Standard and EN 60079-15:2005

This European Standard supersedes EN 60079-15:2005.

The significant changes with respect to EN 60079-15:2005 are as listed below.

	Type		
	Minor and editorial changes	Extension	Substantial change regarding ESR's ^a
Addition of Equipment Protection Levels		X	
Removal of the requirements for Energy-limited "nL" and associated energy limited apparatus "[nL]"		X	
Removal of the requirements for Encapsulated Devices "nC"		X	
Requirements for electrical connections expanded and clarified		X	
Requirements for luminaire ballasts expanded and clarified		X	
Requirements for evaluation and testing of motors rotors clarified	X		
15 kV limit for Equipment protection by type of protection "n" added		X	
Spacing requirement for voltages above 10 kV modified		X	
Requirements for restricted breathing enclosures modified		X	
Modification to requirements for motor rotors and stators		X	
Addition of Annex A (informative): Information on installation of nA machines to be considered for eventual inclusion into IEC 60079-14	X		
^a ESR = Essential Health and Safety Requirements (Annex II of Directive 94/9/EC)			

General conclusion on the change of the State of the Art by this standard

CENELEC/TC 31 as the responsible committee has concluded that this new edition does not contain substantial changes regarding the ESRs.

Annex ZZ
(informative)

Coverage of essential requirements of the directive 94/9/EC

This European Standard has been prepared under a mandate given to CENELEC by the European Commission and the European Free Trade Association and within its scope the standard covers only the following essential safety requirements out of those given in Annex II of the EU Directive 94/9/EC:

ESR	Equivalent requirement in EN 60079-15:2010
1.0.1 dash 2	Definition 3.7 of EN 60079-15 and principles of the type of protection "n" for gas atmospheres
1.0.2	Definition 3.7 and Notes of EN 60079-15 and reference to EN 60079-0
1.0.3	Reference to EN 60079-0
1.0.4	Reference to EN 60079-0
1.0.5	Clause 24 of EN 60079-15 and reference to EN 60079-0
1.0.6	Clause 25 of EN 60079-15 and reference to EN 60079-0
1.1	Reference to EN 60079-0
1.2.1	Generally covered by EN 60079-15 and EN 60079-0
1.2.2	Reference to EN 60079-0
1.2.3	Not applicable. Release of flammable material is not foreseen
1.2.4	Not applicable. Dust atmospheres and deposits are out of scope
1.2.5	Reference to EN 60079-0
1.2.6	Warning label deemed adequate for Category 3 Equipment
1.2.7	Reference to EN 60079-0 and relevant standards for normal industrial applications.
1.2.8	Not specifically applied to Category 3 Equipment but covered in general for normal conditions by the installation requirements in EN 60079-14
1.2.9	Clause 17 of EN 60079-15
1.3.1	Principle of the type of protection "n" as far as applicable and reference to EN 60079-0
1.3.2	Reference to EN 60079-0
1.3.3	Reference to EN 60079-0
1.3.4	Clauses 8.7 of EN 60079-15 and reference to EN 60079-0
1.3.5	Not applicable to electrical equipment
1.4	Reference to EN 60079-0
1.5.1	Clause 12 in respect of charging of batteries
1.5.2 to 1.5.8	Not applicable
1.6.1 to 1.6.3	Not applicable
1.6.4	Reference to EN 60079-0
1.6.5	Not applicable

ESR	Equivalent requirement in EN 60079-15:2005
2.0, 2.1 and 2.2	Not applicable – out of scope
2.3.1	Fundamental basis of EN 60079-15 and references to EN 60079-0
2.3.2	Not applicable – out of scope
3	Not applicable – out of scope

<http://www.china-gauges.com/>

<http://www.china-gauges.com/>

CONTENTS

1	Scope	7
2	Normative references	14
3	Terms and definitions	15
4	General	17
4.1	Equipment grouping and temperature classification	17
4.2	Potential ignition sources	17
5	Temperatures	17
5.1	Maximum surface temperature	17
5.2	Small components	18
6	Requirements for electrical equipment	18
6.1	General	18
6.2	Opening times	18
6.3	Minimum degree of protection	18
6.3.1	General	18
6.3.2	Degree of protection provided by installation	18
6.4	Clearances, creepage distances and separations	18
6.4.1	General	18
6.4.2	Determination of working voltage	19
6.4.3	Conformal coating	19
6.4.4	Comparative tracking index (CTI)	19
6.4.5	Measurement of creepage and clearance	19
6.4.6	Compound filled cable sealing boxes	21
6.5	Electric strength	26
6.5.1	Insulation from earth or frame	26
6.5.2	Insulation between conductive parts	26
7	Connection facilities and terminal compartments	27
7.1	General	27
7.2	Field wiring connections	27
7.2.1	General	27
7.2.2	Connections made using terminals complying with IEC 60947-7-1, IEC 60947-7-2, IEC 60999-1, or IEC 60999-2	28
7.2.3	Field wiring connection facilities integral to “n” equipment or components	28
7.2.4	Connections designed to be used with cable lugs and similar devices	28
7.2.5	Connections using permanent arrangements	28
7.3	Factory connections	28
7.3.1	General	28
7.3.2	Field wiring connection methods used for factory connections	28
7.3.3	Other factory connections	28
7.3.4	Permanent connections	28
7.3.5	Pluggable connections	29
7.3.6	Terminal bridging connections	29
8	Supplementary requirements for non-sparking electrical machines	29
8.1	General	29
8.2	Machine enclosure	30

8.3	Terminal boxes.....	30
8.4	Conduit stopping boxes, cable sealing and dividing boxes.....	30
8.5	Connection facilities for external conductors.....	30
8.6	Neutral point connections.....	30
8.7	Radial air gap.....	31
8.8	Rotor cages.....	31
8.8.1	Rotor cages built from bars connected to end rings.....	31
8.8.2	Cast rotor cages.....	31
8.8.3	Assessment for possible air gap sparking.....	31
8.9	Stator winding insulation system.....	32
8.10	Surface temperature limitation.....	33
8.10.1	Prevention of thermal oxidation.....	33
8.10.2	Operation with a frequency convertor or a non-sinusoidal supply.....	33
9	Supplementary requirements for non-sparking fuses and fuse assemblies.....	34
9.1	Fuses.....	34
9.2	Temperature class of equipment.....	34
9.3	Fuse mounting.....	34
9.4	Fuse enclosures.....	34
9.5	Replacement fuse identification.....	34
10	Supplementary requirements for non-sparking plugs and sockets.....	34
10.1	Plugs and sockets for external connections.....	34
10.2	Maintaining degree of protection (IP code).....	35
10.3	Sockets that do not have plugs inserted in normal operation.....	35
11	Supplementary requirements for non-sparking luminaires.....	35
11.1	General.....	35
11.2	Construction.....	35
11.2.1	General.....	35
11.2.2	Enclosure of lamp.....	36
11.2.3	Lampholders.....	36
11.2.4	Auxiliaries.....	37
11.2.5	Creepage distances and clearances.....	38
11.2.6	Terminals.....	39
11.2.7	Internal wiring.....	39
11.3	Luminaires for tubular fluorescent bi-pin lamps.....	39
11.3.1	General.....	39
11.3.2	Maximum ambient temperature.....	39
11.3.3	Temperature class.....	39
11.3.4	Endurance tests and thermal tests.....	40
11.3.5	Resistance to dust and moisture.....	41
11.3.6	Insulation resistance and electric strength.....	41
11.4	Other equipment containing light sources.....	41
12	Supplementary requirements for equipment incorporating non-sparking cells and batteries.....	41
12.1	General.....	41
12.2	Categorization of cells and batteries.....	41
12.2.1	Type 1 cells and batteries.....	41
12.2.2	Type 2 cells and batteries.....	42
12.2.3	Type 3 cells and batteries.....	42

12.3	General requirements for cells and batteries of types 1 and 2	43
12.3.1	General	43
12.3.2	Maximum capacity	43
12.3.3	Secondary cells	43
12.3.4	Cell connection	43
12.3.5	Discharge mode	43
12.3.6	Temperature	43
12.3.7	Creepage and clearance	43
12.3.8	Connections	43
12.3.9	Connecting cells in series	43
12.3.10	Deep discharge protection	43
12.3.11	Temperature test conditions	44
12.3.12	Battery parts	44
12.3.13	Battery pack connections	44
12.3.14	Cell electrolyte and gas release	44
12.3.15	Excessive load draw	44
12.4	Charging of type 1 and type 2 cells and batteries	44
12.4.1	Temperature range	44
12.4.2	Charger specifications	44
12.4.3	Charging separated cells or batteries	44
12.4.4	Charger limitations	44
12.4.5	Charging outside the hazardous area	44
12.4.6	Gassing during charging of type 2 cells or batteries	45
12.5	Requirements for type 3 secondary batteries	45
12.5.1	Types of permissible batteries	45
12.5.2	Battery containers	45
12.5.3	Cells	46
12.5.4	Connections	47
12.6	Verification and tests	47
12.6.1	Insulation resistance	47
12.6.2	Mechanical shock test	47
13	Supplementary requirements for non-sparking low power equipment	47
14	Supplementary requirements for non-sparking current transformers	49
15	Other non-sparking electrical equipment	49
16	General supplementary requirements for equipment producing arcs, sparks or hot surfaces	49
17	Supplementary requirements for enclosed-break devices and non-incendive components producing arcs, sparks or hot surfaces	49
17.1	Type testing	49
17.2	Ratings	49
17.2.1	Enclosed-break devices	49
17.2.2	Non-incendive components	50
17.3	Construction of enclosed-break devices	50
17.3.1	Free internal volume	50
17.3.2	Continuous operating temperature (COT) requirements	50
17.3.3	Seal protection	50
18	Supplementary requirements for hermetically sealed devices producing arcs, sparks or hot surfaces	50

19	Supplementary requirements for sealed devices producing arcs, sparks or hot surfaces	50
19.1	Non-metallic materials	50
19.2	Opening	50
19.3	Internal spaces	50
19.4	Handling	51
19.5	Gasket and seals	51
19.6	Type tests	51
20	Supplementary requirements for restricted-breathing enclosures protecting equipment producing arcs, sparks or hot surfaces	51
20.1	General	51
20.2	Constructional requirements	51
20.2.1	Type of equipment	51
20.2.2	Cable grips and conduit entries	52
20.2.3	Operating rods, spindles and shafts	52
20.2.4	Windows	52
20.2.5	Gasket and seal requirements	53
20.2.6	Non-resilient seals	53
20.2.7	Test port	53
20.2.8	Internal fans	54
20.2.9	Routine test exemptions	54
20.3	Temperature limitation	54
20.3.1	General	54
20.3.2	Temperature calculation	54
20.4	Additional requirements for restricted breathing luminaires	55
20.4.1	Mounting arrangement	55
20.4.2	Reflectors	55
20.4.3	Surface temperatures of restricted breathing luminaires	55
21	General information on verification and tests	55
22	Type tests	55
22.1	Representative samples	55
22.2	Test configuration	55
22.3	Tests for enclosures on which the type of protection depends	55
22.3.1	Thermal endurance tests	55
22.4	Tests for enclosed break devices and non incensive components	56
22.4.1	Preparation of enclosed-break device samples	56
22.4.2	Preparation of non-incensive component samples	56
22.4.3	Test conditions for enclosed-break devices and non-incensive components	56
22.5	Tests for sealed devices	57
22.5.1	Conditioning	57
22.5.2	Voltage test	57
22.5.3	Tests on devices with free space	57
22.5.4	Test for sealed devices for luminaires	58
22.6	Type test requirements for restricted-breathing enclosures	58
22.6.1	General	58
22.6.2	Test procedures	59
22.6.3	Alternative Type test for equipment where the nominal volume of the enclosure changes due to pressure	59

<http://www.china-gauges.com/>

- 22.7 Test for screw lampholders.....59
- 22.8 Test for starter holders for luminaires 60
- 22.9 Tests for electronic starters for tubular fluorescent lamps and for ignitors for high pressure sodium or metal halide lamps 60
 - 22.9.1 General 60
 - 22.9.2 Moisture resistance, insulation and electric strength test 60
 - 22.9.3 Cut-out device test 60
 - 22.9.4 Life test (failed lamp) 61
- 22.10 Test for wiring of luminaires subject to high-voltage impulses from ignitors..... 61
- 22.11 Mechanical shock test for batteries..... 62
 - 22.11.1 General..... 62
 - 22.11.2 Test procedure 62
 - 22.11.3 Evaluation criteria 62
- 22.12 Insulation resistance test for batteries 62
 - 22.12.1 Test conditions..... 62
 - 22.12.2 Evaluation criteria 63
- 22.13 Additional ignition tests for large or high-voltage machines..... 63
 - 22.13.1 Test for cage rotor construction..... 63
 - 22.13.2 Test for stator winding insulation system incendivity..... 63
- 23 Routine verifications and tests..... 64
 - 23.1 General..... 64
 - 23.2 Specific routine tests 64
 - 23.2.1 Electric strength test..... 64
 - 23.2.2 Alternate dielectric strength test 64
 - 23.2.3 Routine test requirements for restricted-breathing enclosures 64
 - 23.2.4 Routine tests for electronic starters and ignitors 65
- 24 Marking 66
 - 24.1 General..... 66
 - 24.2 Where IP marking is required equipment shall be marked in accordance with 6.3. Additional marking for batteries 66
 - 24.3 Examples of marking 67
 - 24.3.1 Warning markings..... 67
- 25 Documentation 68
- 26 Instructions..... 68
- Annex A (informative) Application, installation, and testing considerations for Ex “nA” asynchronous machines..... 69
- Bibliography..... 71

- Figure 1 – Examples for determining clearances and creepage distances 26

- Table 1 – Relationship of this part to IEC 60079-0 10
- Table 2 – Minimum creepage distances, clearances and separations..... 20
- Table 3 – Tracking resistance of insulating materials 21
- Table 4 – Separation in compound-filled cable sealing boxes 22
- Table 5 – Assumed voltage of neutral points..... 30
- Table 6 – Potential air gap sparking risk assessment for cage rotor ignition risk factors..... 32
- Table 7 – Minimum distance between lamp and protective cover 36

Table 8 – Creepage distances and clearances at peak values of pulse voltages greater than 1,5 kV	39
Table 9 – Types and use of cells and batteries	42
Table 10 – Minimum creepage distances, clearances and separations for low power equipment.....	48
Table 11 – Insertion torque	59
Table 12 – Minimum removal torque	60
Table 13 – Explosion test mixtures	64
Table 14 – Text of warning markings	67

<http://www.china-gauges.com/>

EXPLOSIVE ATMOSPHERES –

Part 15: Equipment protection by type of protection "n"

1 Scope

This part of IEC 60079 specifies requirements for the construction, testing and marking for Group II electrical equipment with type of protection "n" intended for use in explosive gas atmospheres. This standard applies to electrical equipment where the rated voltage does not exceed 15 kV r.m.s. a.c. or d.c.

This part of IEC 60079 is applicable to non-sparking electrical equipment and also to electrical equipment with parts or circuits producing arcs or sparks or having hot surfaces which, if not protected in one of the ways specified in this standard, could be capable of igniting a surrounding explosive gas atmosphere. This standard describes several different methods by which this can be achieved which may be combined with other methods described in IEC 60079-0.

This standard supplements and modifies the general requirements of IEC 60079-0, except as indicated in Table 1. Where a requirement of this standard conflicts with a requirement of IEC 60079-0, the requirement of this standard takes precedence.

Table 1 – Relationship of this part to IEC 60079-0

Clause of IEC 60079-0			IEC 60079-0 clause application to IEC 60079-15		
Ed. 5.0 (2007) (informative)	Ed. 6.0 ¹ (future edition) (informative)	Clause / Subclause title (normative)	Protected sparking nC	Non sparking nA	Restricted breathing nR
4	4	Equipment grouping	Applies	Applies	Applies
4.1	4.1	Group I	Excluded	Excluded	Excluded
4.2	4.2	Group II	Applies	Applies	Applies
4.3	4.3	Group III	Excluded	Excluded	Excluded
4.4	4.4	Equipment for a particular explosive atmosphere	Applies	Applies	Applies
5.1	5.1	Environmental influences	Applies	Applies	Applies
5.1.1	5.1.1	Ambient temperature	Applies	Applies	Applies
5.1.2	5.1.2	External source of heating or cooling	Applies	Applies	Applies
5.2	5.2	Service temperature	Applies	Applies	Applies
5.3.1	5.3.1	Determination of maximum surface temperature	Applies	Applies	Applies
5.3.2.1	5.3.2.1	Group I electrical equipment	Excluded	Excluded	Excluded

¹ Under consideration.

Clause of IEC 60079-0			IEC 60079-0 clause application to IEC 60079-15		
Ed. 5.0 (2007) (informative)	Ed. 6.01 (future edition) (informative)	Clause / Subclause title (normative)	Protected sparking nC	Non sparking nA	Restricted breathing nR
5.3.2.2	5.3.2.2	Group II electrical equipment	Applies	Applies	Applies
5.3.2.3	5.3.2.3	Group III electrical equipment	Excluded	Excluded	Excluded
5.3.3	5.3.3	Small component temperature for Group I and Group II electrical equipment	Applies	Applies	Excluded
6.1	6.1	General	Applies	Applies	Applies
6.2	6.2	Mechanical strength	Applies	Applies	Applies
6.3	6.3	Opening times	Excluded	Excluded	Applies
6.4	6.4	Circulating currents	Applies	Applies	Applies
6.5	6.5	Gasket retention	Applies	Applies	Applies
6.6	6.6	Electromagnetic and ultrasonic radiating equipment	Applies	Applies	Applies
7.1.1	7.1.1	Applicability	Applies	Applies	Applies
7.1.2	7.1.2	Specification of materials	Applies	Applies	Applies
7.1.3	7.1.2.2	Plastic materials	Applies	Applies	Applies
7.1.4	7.1.2.3	Elastomeric materials	Applies	Applies	Applies
7.2	7.2	Thermal endurance	Applies	Applies	Applies
7.3	7.3	Resistance to light	Applies	Applies	Applies
7.4	7.4	Electrostatic charges on external non-metallic materials	Applies	Applies	Applies
7.5	9.1	Threaded holes	Applies	Applies	Applies
8.1.1	8.2	Group I	Excluded	Excluded	Excluded
8.1.2	8.3	Group II	Applies	Applies	Applies
8.1.3	8.4	Group III	Excluded	Excluded	Excluded
8.2	9.1	Threaded holes	Applies	Applies	Applies
9.1	9.1	General	Applies	Applies	Applies
9.2	9.2	Special fasteners	Excluded	Excluded	Excluded
9.3	9.3	Holes for special fasteners	Excluded	Excluded	Excluded
10	10	Interlocking devices	Excluded	Excluded	Excluded
11	11	Bushings	Applies	Applies	Applies
12	12	Materials used for cementing	Modified	Modified	Modified
13	13	Ex components	Applies	Applies	Applies
14	14	Connection facilities and termination compartments	Modified	Modified	Modified
15	15	Connection facilities for earthing and bonding conductors	Applies	Applies	Applies

Clause of IEC 60079-0			IEC 60079-0 clause application to IEC 60079-15		
Ed. 5.0 (2007) (informative)	Ed. 6.01 (future edition) (informative)	Clause / Subclause title (normative)	Protected sparking nC	Non sparking nA	Restricted breathing nR
16	16	Entries into enclosures	Applies	Applies	Applies
17	17	Supplementary requirements for rotating electrical machines	Excluded	Modified	Excluded
18	18	Supplementary requirements for switchgear	Applies	Applies	Applies
19	19	Supplementary requirements for fuses	Modified	Modified	Modified
20	20	Supplementary requirements for plugs and sockets	Modified	Modified	Modified
21	21	Supplementary requirements for luminaires	Modified	Modified	Modified
22	22	Supplementary requirements for caplights and handlights	Applies	Applies	Applies
23	23	Equipment incorporating cells and batteries	Modified	Modified	Modified
24	24	Documentation	Applies	Applies	Applies
25	25	Compliance of prototype or sample with documents	Applies	Applies	Applies
26.1	26.1	General	Applies	Applies	Applies
26.2	26.2	Test configuration	Applies	Applies	Applies
26.3	26.3	Tests in explosive test mixtures	Applies	Applies	Applies
26.4	26.4	Tests of enclosures	Applies	Applies	Applies
26.4.1.1	26.4.1.1	Metallic enclosures, metallic parts of enclosures and glass parts of enclosures	Applies	Applies	Applies
26.4.1.2.1	26.4.1.2.1	Group I electrical equipment	Excluded	Excluded	Excluded
26.4.1.2.2	26.4.1.2.2	Group II and Group III electrical equipment	Applies	Applies	Applies
26.4.2	26.4.2	Resistance to impact	Applies	Applies	Applies
26.4.3	26.4.3	Drop test	Applies	Applies	Applies
26.4.4	26.4.4	Acceptance criteria	Applies	Applies	Applies
26.4.5	26.4.5	Degree of protection by enclosure	Applies	Applies	Applies
26.5	26.5	Thermal tests	Applies	Applies	Applies
26.6	26.6	Torque test for bushings	Applies	Applies	Applies
26.7	26.7	Non-metallic enclosures or non-metallic parts of enclosures	Modified	Modified	Modified
26.8	26.8	Thermal endurance to heat	Modified	Modified	Modified

Clause of IEC 60079-0			IEC 60079-0 clause application to IEC 60079-15		
Ed. 5.0 (2007) (informative)	Ed. 6.01 (future edition) (informative)	Clause / Subclause title (normative)	Protected sparking nC	Non sparking nA	Restricted breathing nR
26.9	26.9	Thermal endurance to cold	Applies	Applies	Applies
26.10	26.10	Resistance to light	Applies	Applies	Applies
26.11	26.11	Resistance to chemical agents for Group I electrical equipment	Excluded	Excluded	Excluded
26.12	26.12	Earth continuity	Applies	Applies	Applies
26.13	26.13	Surface resistance test of parts of enclosures of non-metallic materials	Applies	Applies	Applies
26.14	-	Charging tests	Applies	Applies	Applies
26.15	26.14	Measurement of capacitance	Applies	Applies	Applies
27	27	Routine tests	Applies	Applies	Applies
28	28	Manufacturers responsibility	Applies	Applies	Applies
29	29	Marking	Applies	Applies	Applies
30	30	Instructions	Applies	Applies	Applies
Annex A	Annex A	Supplementary requirements for Ex cable glands	Applies	Applies	Applies
Annex B	Annex B	Requirements for Ex components	Applies	Applies	Applies
Annex C	Annex C	Example of rig for resistance to impact test	Applies	Applies	Applies
Annex D	Annex D	Introduction to an alternative risk assessment method encompassing "equipment protection levels" for Ex equipment	Applies	Applies	Applies
<p>Applies : this requirement of IEC 60079-0 is applied without change.</p> <p>Excluded : this requirement of IEC 60079-0 does not apply.</p> <p>Modified : this requirement of IEC 60079-0 is modified as detailed in this standard.</p>					

NOTE 1 The clause number in the above table is shown for information only. The applicable requirements of IEC 60079-0 are identified by the clause title which is normative. This document was written against the specific requirements of IEC 60079-0 (ed. 5.0). The clause numbers for the previous edition are shown for information only. This is to enable the General Requirements IEC 60079-0 (ed. 5.0) to be used where necessary with this part of IEC 60079. Where there were no requirements, indicated by "NR" or there is a conflict between requirements, the later edition requirements take precedence.

NOTE 2 A non-incendive component is limited in use to the particular circuit for which it has been shown to be non-ignition capable and, therefore, cannot be separately assessed as complying with this standard.

NOTE 3 Compliance with this standard does not imply any removal of, or lowering of the requirements of any other standard with which the electrical equipment complies.

NOTE 4 This part of IEC 60079 supplements, and may enhance, the requirements for equipment for normal industrial applications. Where compliance with other IEC standards is indicated, such as IEC 60034 for motors and IEC 60598-2 for luminaires, proving compliance to those standards is normally the responsibility of the manufacturer.

NOTE 5 Type of protection “n” provides Equipment Protection Level (EPL) Gc. For further information, see IEC 60079-0.

2 Normative references

The following referenced documents are indispensable for the application of this document. For dated references, only the edition cited applies. For undated references, the latest edition of the referenced document (including any amendments) applies.

IEC 60034 (all parts), *Rotating electrical machines*

IEC 60034-1, *Rotating electrical machines – Part 1: Rating and performance*

IEC/TS 60034-25, *Rotating electrical machines – Part 25: Guidance for the design and performance of a.c. motors specifically designed for converter supply*

IEC 60061 (all parts), *Lamp caps and holders together with gauges for the control of interchangeability and safety*

IEC 60061-1, *Lamp caps and holders together with gauges for the control of interchangeability and safety – Part 1: Lamp caps*

IEC 60068-2-27:2008, *Environmental testing – Part 2-27: Tests – Test Ea and guidance: Shock*

IEC 60079-0:2007, *Explosive atmospheres – Part 0: Equipment – General requirements*

IEC 60079-1, *Explosive atmospheres – Part 1: Equipment protection by flameproof enclosures “d”*

IEC 60079-11, *Explosive atmospheres – Part 11: Equipment protection by intrinsic safety “i”*

IEC 60112, *Method for the determination of the proof and the comparative tracking indices of solid insulating materials*

IEC 60155, *Glow-starters for fluorescent lamps*

IEC 60228, *Conductors of insulated cables*

IEC 60238, *Edison screw lampholders*

IEC 60269-3, *Low-voltage fuses – Part 3: Supplementary requirements for fuses for use by unskilled persons (fuses mainly for household and similar applications) – Examples of standardized systems of fuses A to F*

IEC 60400, *Lampholders for tubular fluorescent lamps and starterholders*

IEC 60529, *Degrees of protection provided by enclosures (IP Code)*

IEC 60598 (all parts), *Luminaires*

IEC 60598-1:2008, *Luminaires – Part 1: General requirements and tests*

IEC 60598-2 (all parts), *Luminaires – Part 2: Particular requirements*

IEC 60664-1:, *Insulation coordination for equipment within low-voltage systems – Part 1: Principles, requirements and tests*

IEC 60927, *Auxiliaries for lamps – Starting devices (other than glow starters) – Performance requirements*

IEC 60947-7-1, *Low-voltage switchgear and controlgear – Part 7-1: Ancillary equipment – Terminal blocks for copper conductors*

IEC 60947-7-2, *Low-voltage switchgear and controlgear – Part 7-2: Ancillary equipment – Protective conductor terminal blocks for copper conductors*

IEC 60998-2-4, *Connecting devices for low-voltage circuits for household and similar purposes – Part 2-4: Particular requirements for twist-on connecting devices*

IEC 60999-1, *Connecting devices – Electrical copper conductors – Safety requirements for screw-type and screwless-type clamping units – Part 1: General requirements and particular requirements for clamping units for conductors from 0,2 mm² up to 35 mm² (included)*

IEC 60999-2, *Connecting devices – Electrical copper conductors – Safety requirements for screw-type and screwless-type clamping units – Part 2: Particular requirements for clamping units for conductors above 35 mm² up to 300 mm² (included)*

IEC 61048, *Auxiliaries for lamps – Capacitors for use in tubular fluorescent and other discharge lamp circuits – Safety and safety requirements*

IEC 61184, *Bayonet lampholders*

IEC 61195, *Double-capped fluorescent lamps – Safety specifications*

IEC 61347-1:2007, *Lamp controlgear – Part 1: General and safety requirements*

IEC 61347-2-1, *Lamp controlgear – Part 2-1: Particular requirements for starting devices (other than glow starters)*

IEC 61347-2-2, *Lamp controlgear – Part 2-2: Particular requirements for d.c. or a.c. supplied electronic step-down convertors for filament lamps*

IEC 61347-2-3, *Lamp controlgear – Part 2-3: Particular requirements for a.c. supplied electronic ballasts for fluorescent lamps*

IEC 61347-2-4, *Lamp controlgear – Part 2-4: Particular requirements for d.c. supplied electronic ballasts for general lighting*

IEC 61347-2-7, *Lamp controlgear – Part 2-7: Particular requirements for d.c. supplied electronic ballasts for emergency lighting*

IEC 61347-2-8, *Lamp controlgear – Part 2-8: Particular requirements for ballasts for fluorescent lamps*

IEC 61347-2-9, *Lamp controlgear – Part 2-9: Particular requirements for ballasts for discharge lamps (excluding fluorescent lamps)*

3 Terms and definitions

For the purposes of this document, the terms and definitions given in IEC 60079-0 and the following apply.

3.1

cable sealing box

auxiliary enclosure provided specifically for the purpose of sealing the insulation of a cable (for example, oil insulated cable) where it is connected to an apparatus

The enclosure may also provide for the connection of separate cable tails to the cable

3.2

clearance

shortest distance in air between two conductive parts

3.3

creepage distance

shortest distance along the surface of a solid insulating material in contact with air between two conductive parts

3.4

duty cycle

repetitive variation of load in which the cycle time is too short for the thermal equilibrium to be attained in the first cycle

[IEV 411-51-07]

3.5

separation

shortest distance through solid insulating material between two conductive parts

3.6

sealing device

device employing a method other than encapsulation to prevent the flow of a gas or a liquid between apparatus and a conduit by providing sealing facilities

3.7

type of protection "n"

type of protection applied to electrical equipment such that, in normal operation and in certain specified regular expected occurrences, it is not capable of igniting a surrounding explosive gas atmosphere

NOTE 1 Additionally, the requirements of this standard are intended to ensure that a malfunction capable of causing ignition is not likely to occur.

NOTE 2 An example of a specified regular expected occurrence is a luminaire with failed lamp.

3.7.1

non-sparking device "nA"

device constructed to minimize the risk of occurrence of arcs or sparks capable of creating an ignition hazard during conditions of normal operation

NOTE For the purposes of this standard normal operation is considered to exclude the removal or insertion of components with the circuit energized.

3.7.2

devices and components "nC"

3.7.2.1

enclosed-break device "nC"

device incorporating electrical contacts that are made and broken and that will withstand an internal explosion of the flammable gas or vapour which may enter it without suffering damage and without communicating the internal explosion to the external flammable gas or vapour

NOTE The principle difference between enclosed break devices "nC" and flameproof "d" are that the dimensions are not controlled and that safety factors have not been added.

3.7.2.2

hermetically-sealed device "nC"

device which is so constructed that the external atmosphere cannot gain access to the interior and in which the seal is made by fusion, for example by soldering, brazing, welding or the fusion of glass to metal

3.7.2.3

non-incendive component "nC"

components having contacts for making or breaking a specified ignition capable circuit but in which the contacting mechanism is designed and constructed so that the component is not capable of causing ignition of the specified explosive gas atmosphere

NOTE The enclosure of the non-incendive component is not intended to either exclude the explosive gas atmosphere or contain an explosion. This is usually applied to specially constructed switch contacts that are mechanically designed to quench any arc or spark so that they are not a source of ignition.

3.7.2.4 sealed device “nC”

device which is so constructed that it cannot be opened during normal service and is sealed effectively to prevent entry of an external atmosphere

3.7.3

restricted-breathing enclosure “nR”

enclosure that is designed to prevent the entry of gases, vapours and mists

3.8

test port

facility to test the integrity of restricted breathing equipment in the field after installation, during initial inspection and during maintenance

4 General

4.1 Equipment grouping and temperature classification

Equipment grouping and temperature classification shall be in accordance with the equipment grouping and temperature clauses of IEC 60079-0.

4.2 Potential ignition sources

In normal operation and in certain regular expected occurrences specified by this standard, the equipment shall not

- a) produce an operational arc or spark unless that arc or spark is prevented from causing ignition of a surrounding explosive atmosphere by one of the methods described in Clauses 16 to 20;
- b) develop a maximum surface temperature in excess of the maximum value appropriate to the temperature class of the equipment, unless the temperature of the surface or hot spot is prevented from causing ignition of a surrounding explosive atmosphere by one of the methods described in Clauses 16 to 20 as appropriate, or is otherwise shown to be safe as specified in 5.1.

Manually operated arcing or sparking components located within an enclosure that have been considered to be not accessible in normal operation without the use of a tool (see fastener general requirements of IEC 60079-0), may be evaluated as non-sparking (nA) components. These components shall be identified in the documentation prepared in accordance with the documentation requirements of IEC 60079-0.

5 Temperatures

5.1 Maximum surface temperature

The maximum surface temperature shall be determined in accordance with the determination of maximum temperature requirements of IEC 60079-0. The surface to be considered shall be:

- for nR equipment and nC equipment: the external surface of the equipment;

- for type nA equipment: the surface of any part of the electrical equipment, including the surface of internal parts to which the explosive gas atmosphere might have access

NOTE This may be the outside surface of "nC" components located within "nA" equipment.

5.2 Small components

For evaluation of small components, the small component temperature requirements of IEC 60079-0 applies. Temperature relaxations for thin wires and printed circuit tracks contained in IEC 60079-11 may also be used in application of this standard.

6 Requirements for electrical equipment

6.1 General

Electrical equipment with type of protection "n" shall comply with the requirements of this standard and the applicable parts of IEC 60079-0 for the method(s) of protection used.

6.2 Opening times

Except for nR restricted breathing enclosures, the opening time requirements of IEC 60079-0 do not apply.

6.3 Minimum degree of protection

6.3.1 General

Unless specified elsewhere in this standard, the enclosure of the equipment, when tested in accordance with IEC 60079-0 shall provide at least the degree of protection described in a) or b) unless safety would not be impaired by contact with solid foreign bodies or water (for example, strain gauges, resistance thermometers, or thermocouples). In this case, the documentation (see Clause 25) shall explain why and shall prescribe any special installation requirements which may be necessary and the equipment shall be marked with the symbol "X" to indicate this special condition of use (see the marking requirements of IEC 60079-0):

- a) IP54 where there are bare live parts or IP44 where there are insulated live parts;
- b) IP4X where there are bare live parts, or IP2X where there are insulated live parts and the equipment is intended for installation only in locations providing adequate protection against the entry of solid foreign objects or water capable of impairing safety, and the equipment is marked with the symbol "X" (see the marking requirements of IEC 60079-0).

For protected equipment, the degree of protection shall be marked according to Clause 24.

NOTE 1 For requirements for rotating electrical machines, see Clause 8.

NOTE 2 For requirements for non-sparking low power equipment, see Clause 13.

6.3.2 Degree of protection provided by installation

Where the enclosure is completed by the installation of the equipment the marking shall include the symbol "X" and the manufacturer shall provide relevant information in the documentation in accordance with Clause 25.

6.4 Clearances, creepage distances and separations

6.4.1 General

Clearances, creepage distances and separations between conductive parts at different potentials shall meet the appropriate values given in Table 2, except in the following cases:

- neutral point connections of rotating electrical machines complying with 8.6;
- luminaires complying with 11.2.5;
- with regard to sealing by conformal coating, encapsulated or solid insulation separation only, equipment subject to the routine electric strength test of 6.5.2;
- instruments and low power equipment complying with Clause 13.

A circuit which is not referred to earth in normal operation shall be assumed to be earthed at the point by which the highest voltage U is obtained.

6.4.2 Determination of working voltage

Clearances and creepage distances shall be determined as a function of the working voltage specified by the manufacturer of the equipment. Where the equipment is intended for more than one rated voltage or for a range of rated voltage, the value of the working voltage to be used shall be based on the highest value of rated voltage.

6.4.3 Conformal coating

A conformal coating, if applied, shall have the effect of sealing the conductors and the insulating material in question against ingress of moisture. It shall adhere to the conductive parts and the insulating material. If the conformal coating is applied by spraying then two separate coats are to be applied. Other methods of application need only one coat, for example dip coating, brushing, vacuum impregnating, but the intention is to achieve an effective, lasting, unbroken seal. A solder mask alone is not considered as a conformal coating, but can be accepted as one of the two coats when an additional coat is applied, provided the solder mask is not damaged during soldering.

Where bare conductors emerge from the coating, the requirements given in Table 2 shall apply to the conformal coating.

6.4.4 Comparative tracking index (CTI)

The required values of creepage distance are dependent on the working voltage, the resistance to tracking of the electrical insulating material and its surface profile.

Table 3 gives the grouping of electrical insulating materials according to the CTI determined in accordance with IEC 60112. The material groups are identical with those given in IEC 60664-1. Inorganic insulating materials, for example glass and ceramics, do not track and need not therefore be subjected to the determination of the CTI. They are conventionally classified in material group I.

NOTE Transient overvoltages are ignored as they will not normally influence tracking phenomena. However, temporary and functional overvoltages may have to be considered depending upon the duration and frequency of occurrence. See 11.2.5 and Table 8 for pulse voltages in luminaire circuits or IEC 60664-1 for additional information.

6.4.5 Measurement of creepage and clearance

Clearances, creepage distances and separations shall be determined with any movable parts adjusted to give the lowest values possible.

Terminals shall be assessed by measurements made with and without conductors of the largest cross-sectional area specified by the terminal manufacturer.

NOTE 1 This implies that screws of unused terminals always should be fully tightened when the equipment is in service.

Clearances and creepage distances for external connections shall comply with Table 2, but with a minimum value of 1,5 mm.

Figure 1 (examples taken from IEC 60664-1) illustrates the features to be taken into account when determining the appropriate clearances or creepage distance.

NOTE 2 Cement within a joint would normally be considered as obstructing a clearance or creepage path.

The effect of ribs or grooves shall be taken into account provided that

- ribs on the surface have a minimum height of 1,5 mm and a minimum thickness of 0,4 mm appropriate to the mechanical strength of the material;
- grooves in the surface have a minimum depth of 1,5 mm and a minimum width of 1,5 mm.

NOTE 3 Projections above or depressions below the surface are considered as being either ribs or grooves irrespective of their geometric form.

Table 2 – Minimum creepage distances, clearances and separations

Voltage a.c. r.m.s. or d.c. (Note 1) V	Minimum creepage distance (Note 2) mm				Minimum clearances and separation mm		
	Material group				In air	Under Coating (Note 3)	Encapsulated or solid insulation (Note 4)
	I	II	IIIa	IIIb			
≤10 (see Note 5)	1	1	1	1	0,4	0,3	0,2
≤12,5	1,05	1,05	1,05	1,05	0,4	0,3	0,2
≤16	1,1	1,1	1,1	1,1	0,8	0,3	0,2
≤20	1,2	1,2	1,2	1,2	0,8	0,3	0,2
≤25	1,25	1,25	1,25	1,25	0,8	0,3	0,2
≤32	1,3	1,3	1,3	1,3	0,8	0,3	0,2
≤40	1,4	1,6	1,8	1,8	0,8	0,6	0,3
≤50	1,5	1,7	1,9	1,9	0,8	0,6	0,3
≤63	1,6	1,8	2	2	0,8	0,6	0,3
≤80	1,7	1,9	2,1	2,1	0,8	0,8	0,6
≤100	1,8	2	2,2	2,2	0,8	0,8	0,6
≤125	1,9	2,1	2,4	2,4	1	0,8	0,6
≤160	2	2,2	2,5	2,5	1,5	1,1	0,6
≤200	2,5	2,8	3,2	3,2	2	1,7	0,6
≤250	3,2	3,6	4	4	2,5	1,7	0,6
≤320	4	4,5	5	5	3	2,4	0,8
≤400	5	5,6	6,3	6,3	4	2,4	0,8
≤500	6,3	7,1	8	8	5	2,4	0,8
≤630	8	9	10	10	5,5	2,9	0,9
≤800	10	11	12,5	–	7	4	1,1
≤1 000	11		13	–	8	5,8	1,7
≤1 250	12		15	–	10	–	–
≤1 600	13		17	–	12	–	–
≤2 000	14		20	–	14	–	–
≤2 500	18		25	–	18	–	–

Voltage a.c. r.m.s. or d.c. (Note 1) V	Minimum creepage distance (Note 2) mm				Minimum clearances and separation mm		
	Material group				In air	Under Coating (Note 3)	Encapsulated or solid insulation (Note 4)
	I	II	IIIa	IIIb			
≤3 200	22		32	–	22	–	–
≤4 000	28		40	–	28	–	–
≤5 000	36		50	–	36	–	–
≤6 300	45		63	–	45	–	–
≤8 000	56		80	–	56	–	–
≤10 000	71	70	100	–	70	–	–
≤11 000	78	110	110	–	75	–	–
≤13 800	98	138	138	–	97	–	–
≤15 000	107	150	150	–	105	–	–

NOTE 1 Voltage steps up to 10 000 V are based on the R10 series. For working voltages up to 1 000 V, the actual working voltage may exceed the value given in the table by up to 10 %.

NOTE 2 Values for creepage distances are derived from IEC 60664-1. Up to 800 V, creepage distances are based on pollution degree 3; values between 2 000 V and 10 000 V are based on pollution degree 2. Other values are interpolated or extrapolated.

NOTE 3 Under a conformal coating, see 6.4.3.

NOTE 4 Completely encapsulated in compound to a minimum depth of 0,4 mm, or separation through solid insulating material, for example the thickness of a printed wiring board.

NOTE 5 At 10 V and below, the value of CTI is not relevant and materials not meeting the requirements for material group IIIb may be acceptable.

NOTE 6 The creepage and clearance values shown are based on a maximum rated voltage tolerance of ±10 %.

Table 3 – Tracking resistance of insulating materials

Material group	Comparative tracking index
I	$600 \leq \text{CTI}$
II	$400 \leq \text{CTI} < 600$
IIIa	$175 \leq \text{CTI} < 400$
IIIb	$100 \leq \text{CTI} < 175$

6.4.6 Compound filled cable sealing boxes

Where compound filled cable sealing boxes are used for the termination of external cables supplying equipment with rated voltages in excess of 750 V, the construction shall be such that the creepage distances and clearances given in Table 4 are obtainable for bare live parts, prior to the pouring of the compound.

NOTE The requirements in Table 4 differ from those in Table 2 to take account of the properties of the compound and the lower degree of certainty as to whether the designed separations are actually achieved in a particular installation. Voltage values are rated values to align with commonly used supply values.

Table 4 – Separation in compound-filled cable sealing boxes

Rated voltage, <i>U</i> a.c. r.m.s. or d.c. <i>V</i>	Creepage distances mm		Clearances mm	
	Between phases	Between phase and earth	Between phases	Between phase and earth
$750 < U \leq 1\ 100$	19	19	12,5	12,5
$1\ 100 < U \leq 3\ 300$	37,5	25	19	12,5
$3\ 300 < U \leq 6\ 600$	63	31,5	25	19
$6\ 600 < U \leq 11\ 000$	90	45	37,5	25
$11\ 000 < U \leq 13\ 800$	110	55	45	31,5
$13\ 800 < U \leq 15\ 000$	120	60	50	35

<http://www.china-gauges.com/>

Dimensions in millimetres

Example 1

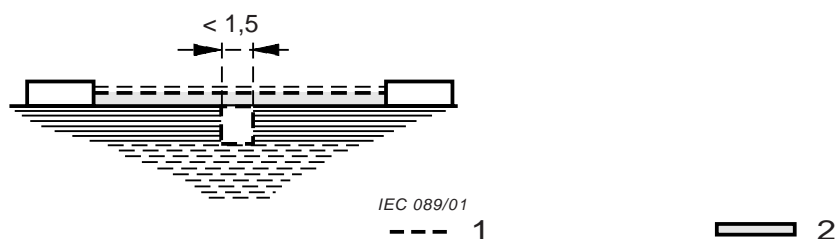

Condition: Path under consideration includes a parallel- or converging-sided groove of any depth with a width less than 1,5 mm

Rule: Creepage distance and clearance are measured directly across the groove as shown

Example 2

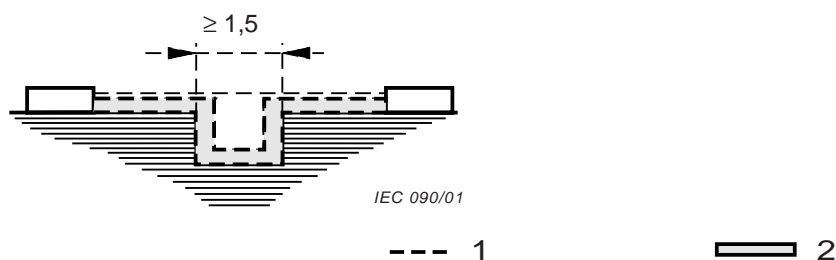

Condition: Path under consideration includes a parallel-sided groove of any depth *d* equal to or more than 1,5 mm

Rule: Clearance is the "line of sight" distance. Creepage path follows the contour of the groove

Example 3

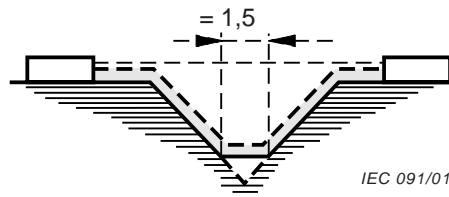

IEC 091/01

1

2

Condition: Path under consideration includes a V-shaped groove with a width greater than 1,5 mm

Rule: Clearance is the "line of sight" distance. Creepage path follows the contour of the groove but "short-circuits" the bottom of the groove by 1,5 mm link

<http://www.china-gauges.com/>

Example 4

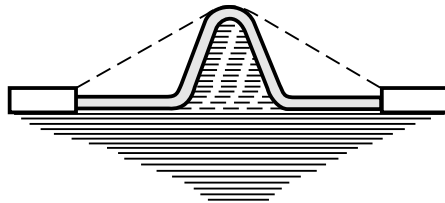

IEC 092/01

1

2

Condition: Path under consideration includes a rib

Rule: Clearance is the shortest direct air path over the top of the rib. Creepage path follows the contour of the rib

Example 5

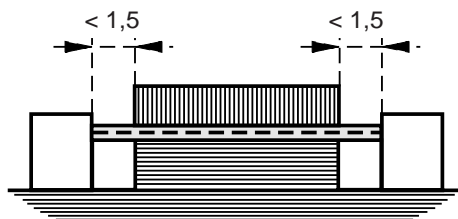

IEC 093/01

1

2

Condition: Path under consideration includes an uncemented joint with grooves less than 1,5 mm wide on each side

Rule: Creepage and clearance path is the "line of sight" distance shown

Example 6

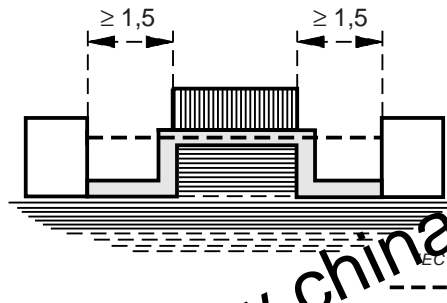

Condition: Path under consideration includes an uncemented joint with grooves equal to or more than 1,5 mm wide on each side

Rule: Clearance is the "line of sight" distance. Creepage path follows the contour of the grooves

<http://www.china-gauges.com/>

Example 7

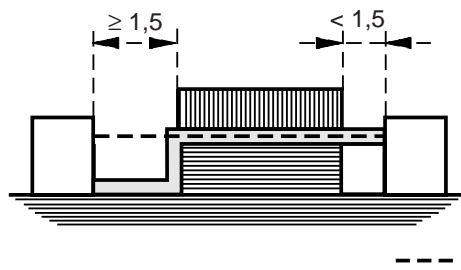

Condition: Path under consideration includes an uncemented joint with a groove on one side less than 1,5 mm wide and the groove on the other side equal to or more than 1,5 mm wide

Rule: Clearance and creepage paths are as shown

Example 8

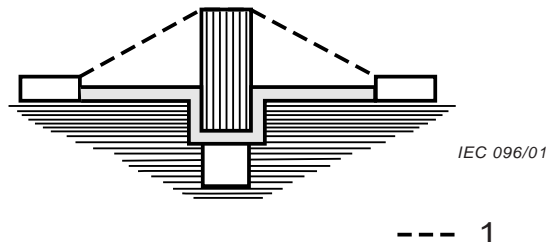

Condition: Creepage distance through uncemented joint is less than creepage distance over barrier

Rule: Clearance is the shortest direct air path over the top of the barrier

Example 9

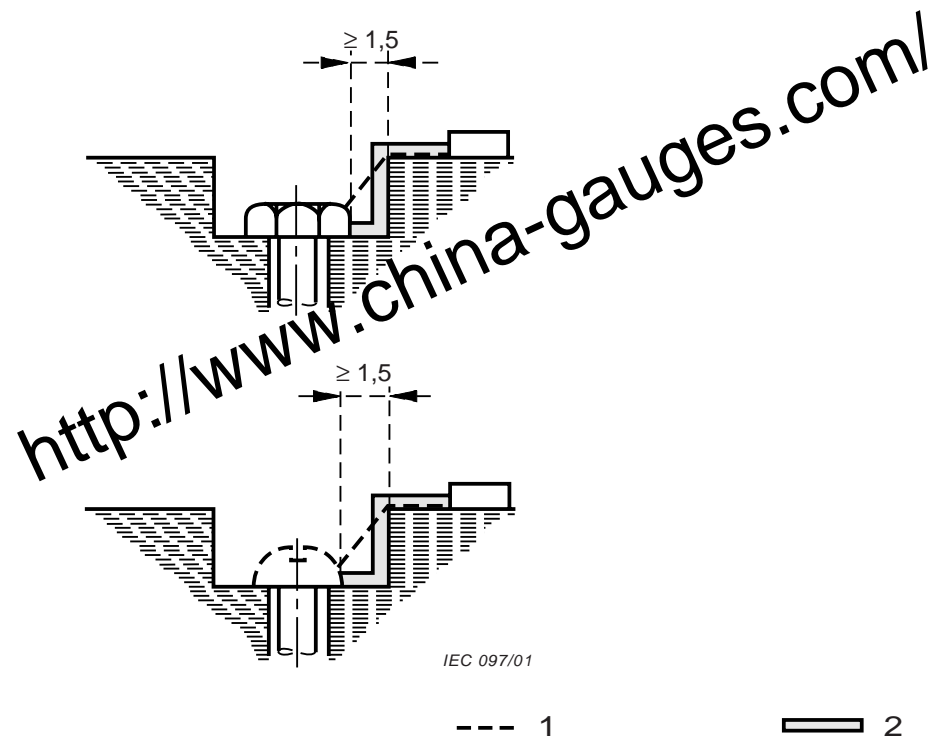

IEC 097/01

Gap between head of screw and wall of recess wide enough to be taken into account

Example 10

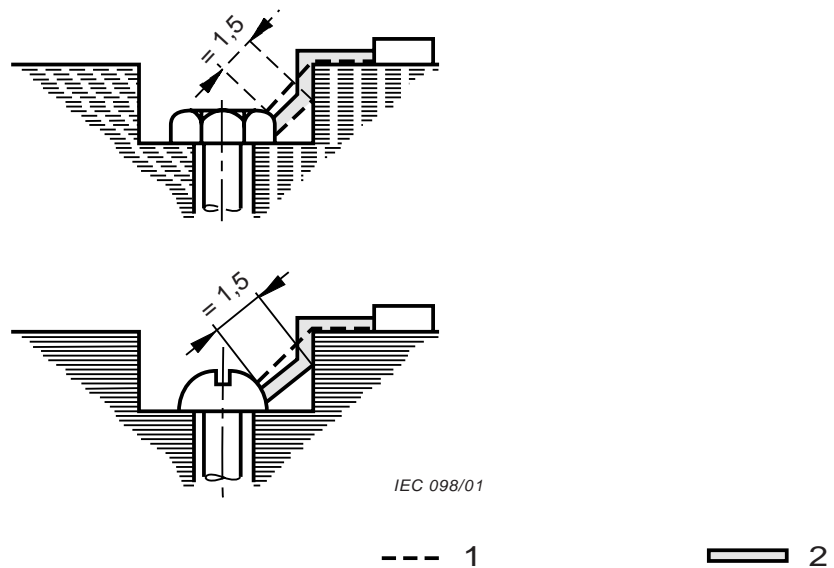

IEC 098/01

Gap between head of screw and wall of recess too narrow to be taken into account

Measurement of creepage distance is from screw to wall when the distance is equal to 1,5 mm

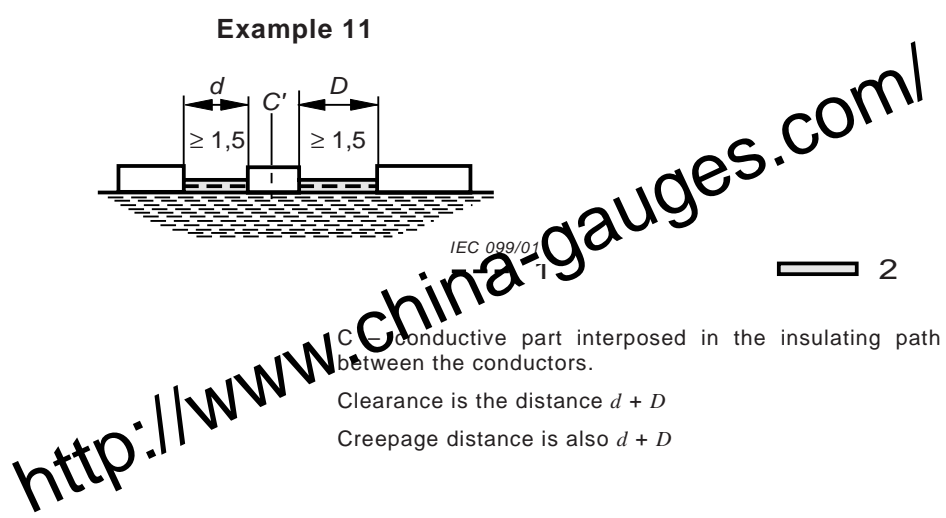

Figure 1 – Examples for determining clearances and creepage distances

6.5 Electric strength

6.5.1 Insulation from earth or frame

Where the electrical circuits within the equipment are not connected directly to the frame of the equipment or not intended to be connected to the frame in service, the insulation or separation distance used shall withstand without breakdown the following test voltages for $(60, \overset{+5}{0})$ s,:

- for equipment supplied with voltages not exceeding 90 V peak or in which internal voltages not exceeding 90 V peak are present, 500 V r.m.s, $\overset{+5}{0}\%$;
- for other equipment, or where internal voltages in excess of 90 V peak are present, $(2 U + 1\ 000\text{ V})$ r.m.s, $\overset{+5}{0}\%$ or 1 500 V r.m.s. $\overset{+5}{0}\%$, whichever is the greater.

The use of a d.c. test voltage is allowed as an alternative to the specified a.c. test voltage and shall be 170 % of the specified a.c. r.m.s test voltage for insulated windings or 140 % of the specified a.c. r.m.s test voltage for situations where air or creepage distance is the insulating medium.

NOTE U is the higher of either the rated supply voltage or the maximum voltage occurring within the equipment.

For equipment with galvanically isolated parts, the test voltages shall be applied separately, at the appropriate voltage, to each part.

6.5.2 Insulation between conductive parts

In the case of equipment subject to the exception of 6.4.1 with regard to sealing by conformal coating, encapsulated or solid insulation separations, and where breakdown could cause an ignition capable arc, spark or hot surface, the insulation or separation between relevant conductive parts shall be subjected to a routine electric strength test carried out in accordance with 6.5.1.

NOTE As such testing can damage electronic components, for example semiconductors, the test may be carried out on equipment using such devices before they are fitted except where they form the actual path to be measured (for example a metal transistor bolted to the equipment frame, where failure of the insulation may directly produce an ignition capable spark or hot surface in the equipment).

7 Connection facilities and terminal compartments

7.1 General

The connection facility and terminal compartment requirements of IEC 60079-0 are supplemented by the following.

Electrical connections are sub-divided into those for field-wiring and for factory wiring and into permanent types and re-connectable/re-wirable types for convenience in detailing the appropriate requirements.

Each type shall, as applicable:

- a) be constructed in such a way that the conductors cannot slip out from their intended location during tightening of a screw or after insertion;
- b) provide a means to avoid loosening of the connection in service;
- c) be such that contact is assured without damage to the conductors such that would impair the ability of the conductors to fulfil their function, even if multi-stranded conductors are used in connections intended for direct clamping of a single conductor;
- d) provide a positive compression force to ensure contact pressure in service;
- e) be constructed in such a way that the contact they ensure is not appreciably impaired by temperature changes occurring in normal service;
- f) except when subjected to the earth continuity test of IEC 60079-0, provide contact pressure that does not depend on the structural integrity of insulating materials;
- g) not be specified to accommodate more than one individual conductor in a clamping point unless specifically designed and assessed for doing so;
- h) if intended for stranded conductors, employ a means to protect the conductors and distribute the contact pressure evenly. The method of applying contact pressure shall be capable, on installation, of reliably forming the stranded conductor into an effectively solid shape that does not subsequently change in service. Alternatively, the method of applying the contact pressure should be such that it is designed to accommodate any settlement of the strands in service;
- i) for screw connections, have a torque value specified by the manufacturer;
- j) for screwless connections intended for class 5 and/or class 6 fine-stranded conductors according to IEC 60228, the fine-stranded wire shall be equipped with a ferrule or the termination shall have a method to open the clamping mechanism so that the conductors are not damaged during the installation of the conductor.

NOTE 1 The use of aluminium wire may cause difficulties by compromising critical creepage and clearance distances when anti-oxidant materials are applied. The connection of aluminium wire to terminals may be accomplished by the use of suitable bi-metallic connection devices providing a copper connection to the terminal.

NOTE 2 Special precautions against vibration and mechanical shock should be considered.

NOTE 3 Special precautions against electrolytic corrosion should be considered.

NOTE 4 Special precautions against corrosion should be considered where ferrous materials are used.

NOTE 5 The limiting temperature of the insulation of terminal blocks and accessories will usually be based on the limiting temperature of the insulation in accordance with the reduction of mechanical strength, but the limiting temperature allocated to the terminal when used in equipment will also depend on the maximum cable insulation temperature rating of the cable which is to be connected.

7.2 Field wiring connections

7.2.1 General

Terminals for field wiring shall be dimensioned to allow the effective connection of conductors of cross-section equal to at least that corresponding to the rated current of the electrical equipment.

Connections shall be located in a position such that where required to be inspected in service they are reasonably accessible.

The number and size of conductors that can be safely connected shall be specified in the descriptive documentation according to IEC 60079-0.

7.2.2 Connections made using terminals complying with IEC 60947-7-1, IEC 60947-7-2, IEC 60999-1, or IEC 60999-2

Such terminals are intended for the connection of copper conductors with the insulation locally removed and without the addition of intermediate parts other than those replicating the form of a bare conductor, such as a ferrule.

Terminals shall be capable of being fixed in their mountings.

7.2.3 Field wiring connection facilities integral to "n" equipment or components

Terminals shall meet the requirements of 7.2.2, where applicable.

7.2.4 Connections designed to be used with cable lugs and similar devices

Such connections shall be fixed in their mountings. A means of securing the cable to prevent rotation or movement shall be provided to avoid either loosening or compromising creepage and clearance. Alternatively, it shall be demonstrated that such rotation or movement is otherwise restricted.

NOTE Rotation or movement may be restricted by the strength of the conductor itself or by external means of strain relief.

7.2.5 Connections using permanent arrangements

These connections are typically tails with crimping or soldering facilities that are intended to be connected during installation using appropriate connection methods. Either a means of fixing the completed connections to a suitable location is to be provided or the completed connections are to be provided with means of reliably insulating them to the requirements of this standard. If the method of connection is by soldering, a method of providing mechanical support of the completed connection shall be provided. The security of the joint shall not rely solely on the solder.

7.3 Factory connections

7.3.1 General

Factory connections shall be either fixed in a specific location or be provided with means of meeting the creepage and clearance requirements of this standard.

7.3.2 Field wiring connection methods used for factory connections

Any of the connection methods suitable for use as field wiring connections may be used for a factory connection.

7.3.3 Other factory connections

In addition to the connection methods given in 7.3.2, twist-on connecting devices meeting the requirements of IEC 60998-2-4 may also be used for factory connections.

7.3.4 Permanent connections

Permanent connections shall only be made by

- a) crimping,
- b) brazing,
- c) welding,
- d) soldering, provided that the conductors are not supported by the soldered connection alone.

7.3.5 Pluggable connections

These connections are designed to be readily connected or disconnected during assembly, maintenance, or repair.

NOTE Typical examples are plug-in components, and cartridge connectors.

Pluggable connections shall provide one of the following:

- a) each connection or group of connections shall be secured with a mechanical retaining device which may or may not be an integral part of the connector, but which, excluding internal friction, provides a force resisting separation of at least 15 N;

NOTE Where a group of individual connections is mechanically linked, special consideration should be given to the security of the connection.

- b) for a lightweight connecting component relying on friction to remain in place and not attached in any way outside of the connection points, the separating force in Newtons shall be greater than 100 times the mass of the component (in kg) and a mechanical retaining device is not required. The force shall be applied gradually near the centre of the component;

If the factory connection may remain energised when separated, it shall be marked in accordance with item b) of Table 14. For small items, adjacent marking can be provided.

7.3.6 Terminal bridging connections

A terminal bridging connection shall have a separating force in newtons that is greater than 100 times the mass of the component (in kg). The force shall be applied gradually near the centre of the component.

8 Supplementary requirements for non-sparking electrical rotating machines

8.1 General

The requirements in this clause apply to rotating machines within the scope of IEC 60034.

For other rotating devices, for example clock motors, and servo motors, the requirements of this standard including those of this clause, shall apply where they are appropriate.

For non-rotating machines, for example linear motors, the requirements of this standard including those of this clause, shall apply where they are appropriate.

NOTE 1 The requirements of this standard assume that the occurrence of an explosive gas atmosphere and a motor start sequence do not occur simultaneously, and may not be suitable in those cases where these two conditions do occur simultaneously. "Normal" operating conditions for electrical machines are assumed to be rated full-load steady conditions. Starting (acceleration) of electrical machines is excluded as part of "normal" operation under duty S1 or S2. Due to the potential for more frequent starts of motors with duty S3 to S10, the requirements for rotor sparking address the risk of rotor sparking during starting as a "normal" condition. The definitions of duty S1 through S10 are in IEC 60034-1.

NOTE 2 Type 'n' high-voltage motors should not be used where the probability of an explosive gas release cannot be totally disassociated with the start sequence as an independent event. The oil seal systems of centrifugal compressors are known to produce such releases during starting and should be subject to assessment. Seal or lubricating oil systems shared between a motor and its driven compressor are not recommended.

NOTE 3 If certification (third party) is sought, it is not a requirement of this standard that the certification body confirm conformance to IEC 60034 (series). The manufacturer should state the basis of compliance in the documentation, see Clause 25.

8.2 Machine enclosure

Machine enclosures containing bare live parts shall provide a degree of protection not less than IP54, as determined in accordance with IEC 60079-0, and not less than IP20 in other cases.

NOTE The bars and rings of rotor cages are not considered to be bare live parts when determining the degree of protection.

8.3 Terminal boxes

Terminal boxes attached to machines operating at voltages up to 1 kV, may be opened to the interior of the machine, only when the IP rating of the machine is IP44 or higher. The external IP protection of the box shall be not less than IP54, as determined in accordance with IEC 60079-0.

8.4 Conduit stopping boxes, cable sealing and dividing boxes

If fitted, conduit stopping boxes, cable sealing and dividing boxes shall provide a degree of protection not less than IP54 as determined in accordance with IEC 60079-0.

8.5 Connection facilities for external conductors

The connection facilities of rotating machines shall comply with Clause 7.

NOTE Due to the size of cables and glands employed with large rotating machines, a “gland plate assembly” is often applied to allow the cable and glands to be removed from the terminal box as an assembly, this avoiding damage to the terminal box, damage to the cable sealing, damage to the cable gland, or subjecting the cable to stresses liable to damage the cable insulation or the conductors.

8.6 Neutral point connections

In the case of neutral point connections which are not intended for use as an alternative supply connection to the machine, the minimum creepage and clearance requirements shall be determined according to the assumed voltage given in Table 5.

Table 5 – Assumed voltage of neutral points

Voltage <i>U</i> a.c. r.m.s or d.c. V	Assumed voltage of neutral point V
≤ 1000	<i>U</i>
1 000 < <i>U</i> ≤ 3 200	1 000
3 200 < <i>U</i> ≤ 6 300	3 200
6 300 < <i>U</i> ≤ 10 000	6 300
10 000 < <i>U</i> ≤ 13 800	10 000

NOTE Voltages shown are derived from IEC 60664-1. When determining the required values for creepage and clearance, the voltage value in the table may be increased by a factor of 1,1 in order to recognize the range of rated voltages in common use.

In the case of neutral point connections within the enclosure of the machine, the neutral connection shall be fully insulated unless the ingress protection is IP44 or greater and the machine is not intended to be connected to an earthed line supply.

8.7 Radial air gap

To avoid contact between stator and rotor, a radial air gap shall be specified in the documentation prepared in accordance with Clause 25 and demonstrated by one of the following means:

- a) measurement of the radial air gap of the test sample;
- b) calculation of the minimum radial air gap;

NOTE 1 It is acknowledged that, with assemblies, all parts will not exist in the worst case dimensions simultaneously. A statistical treatment of the tolerances, such as "RMS", may need to be applied to demonstrate adequate minimum radial air gap.

NOTE 2 It is not a requirement of this standard that the manufacturer's gap calculations be verified. Also, it is not a requirement of this standard that gap be verified by measurement.

- c) construction in accordance with the following equation:

$$\text{Minimum radial air gap} = \left[0,15 + \left(\frac{D - 50}{780} \right) \left(0,25 + 0,75 \frac{n}{1000} \right) \right] r \times b$$

where

$D = 75$ (for rotor diameters less than 75 mm); or

D is the rotor diameter in millimetres (for values between 75 mm and 750 mm);

$D = 750$ (for rotor diameters greater than 750 mm);

$n = 1\,000$ (for maximum rated speeds not greater than 1 000 r/min); or

n is the maximum rated speed (for values above 1 000 r/min);

$r = 1$ (when the ratio of core length to rotor diameter is not greater than 1,75);

$r = \frac{\text{core length}}{1,75 \times \text{diameter of rotor}}$ (when the value of the expression is greater than 1);

$b = 1$ (for machines with rolling bearings); or

$b = 1,5$ (for machines with plain bearings).

8.8 Rotor cages

8.8.1 Rotor cages built from bars connected to end rings

The joints between bars and short-circuiting rings shall be brazed or welded and compatible materials shall be used to enable high quality joints to be made.

8.8.2 Cast rotor cages

Cast rotor cages shall be made by pressure die-casting or centrifugal casting or equivalent techniques.

8.8.3 Assessment for possible air gap sparking

Rotating electrical machines with a rated output exceeding 100 kW and being other than a duty type S1 or S2, shall be assessed for possible air gap sparking as follows:

If the total sum of the factors determined by Table 6 is greater than 6, one of the following shall be applied:

- a) the machine or a representative sample shall be tested in accordance with 22.13.1; or
- b) the machine design shall allow special measures to be applied during starting to ensure that its enclosure does not contain an explosive gas atmosphere at the time of starting. In

this case, the machine marking shall include the symbol "X", in accordance with item i) of 29.2 of IEC 60079-0, and the specific conditions of use to be employed shall be specified in the documentation as required by Clause 25; or

- c) the starting current of the machine is required to be limited to 300 % of rated current. When external current limiting is required, the machine marking shall include the symbol "X", in accordance with the marking requirements of IEC 60079-0, and the specific conditions of use shall include that the motor is suitable only for reduced voltage starting which limits the starting current to 300 % of the rated current.

NOTE 1 The use of a converter to provide the current limitation is generally an acceptable solution. For other reduced voltage starting methods, the motor and the reduced-voltage starter need to be carefully coordinated.

NOTE 2 Special measures that can be applied include pre-start ventilation to remove any ignitable accumulation of flammable gases or the application of fixed gas detection (see IEC 60079-29-2) inside the machine enclosure to confirm that the machine is free of ignitable concentrations of flammable gases. Other methods may be applied with the agreement of the manufacturer and the user.

Table 6 – Potential air gap sparking risk assessment for cage rotor ignition risk factors

Characteristic	Value	Factor
Rotor cage construction	Uninsulated bar fabricated rotor cage	3
	Open slot cast aluminium rotor cage ≥ 200 kW per pole	2
	Open slot cast aluminium rotor cage < 200 kW per pole	1
	Closed slot cast rotor cage	0
	insulated bar rotor cage	0
Number of poles	2-pole	2
	4-pole to 8-pole	1
	> 8 -pole	0
Rated output	> 500 kW per pole	2
	> 200 kW to 500 kW per pole	1
	≤ 200 kW per pole	0
Radial cooling ducts in rotor	Yes: $L < 200$ mm (Note 1)	2
	Yes: $L \geq 200$ mm (Note 1)	1
	No	0
Rotor or stator skew	Yes: > 200 kW per pole	2
	Yes: ≤ 200 kW per pole	0
	No	0
Rotor overhang parts	Non-compliant (Note 2)	2
	Compliant (Note 2)	0
Temperature class	T1 / T2	2
	T3	1
	$\geq T4$	0

NOTE 1 L is the length of end packet of core. Experimental tests have shown that sparking occurs predominantly in ducts near the ends of the core.

NOTE 2 Rotor overhang parts should be designed to eliminate intermittent contact and to operate within the temperature classification. Compliance with this ruling gives a factor of 0, otherwise it is 2.

8.9 Stator winding insulation system

Type tests of the stator winding insulation system shall be conducted in accordance with 22.13.2 for the following constructions:

- Equipment Group IIB or IIC – rated voltage exceeding 1 kV;
- Equipment Group IIA – rated voltage exceeding 1 kV for random-wound stators; or
- Equipment Group IIA – rated voltage exceeding 6,6 kV for form-wound stators.

For all stators with a rated voltage above 1 kV, the machine shall be fitted with anti-condensation heaters.

NOTE It is recommended that partial discharges be minimized for all high-voltage windings. For windings with a rated voltage of 6,6 kV, or greater, the use of partial discharge suppressant material is recommended.

8.10 Surface temperature limitation

NOTE Calculations or tests may be accepted as evidence of compliance with Clause 5 of IEC 60079-0.

8.10.1 Prevention of thermal ignition

The temperature of any external or internal surface to which the explosive gas atmosphere has access shall not, under normal operating conditions, exceed the temperature class in accordance with Clause 5.

The temperature rise during starting is not one of the factors when determining the temperature class if the duty type is S1 or S2 in accordance with IEC 60034-1.

For duty types S3 to S10 starting and load variations shall be taken into consideration.

If a rotating electrical machine is to operate on more than one duty type, it may, as a consequence, have more than one temperature class. In this case the machine shall be marked with the relevant duty types (S1 – S10) and the related temperature classes.

NOTE 1 The exclusion of the consideration of starting conditions in assigning temperature class is appropriate for machines that start occasionally as the probability of an explosive gas atmosphere being present during the starting sequence is considered an acceptable risk.

NOTE 2 For the purpose of assigning temperature class, bringing up to speed of a generator by a converter should be treated as equivalent to the starting of a motor.

8.10.2 Operation with a frequency convertor or a non-sinusoidal supply

8.10.2.1 Test methods

To prove that the thermal limits are not exceeded and functional performance is demonstrated throughout the operational speed range, two methods may be used: a type test or calculation.

8.10.2.2 Type test for a specific converter

Motors supplied at varying frequency and voltage by a convertor shall be tested with the specified convertor or with a comparable convertor in reference to the output voltage and current specifications. The test shall be performed using the detecting or measurement devices used for protection in normal operation. The descriptive documentation for the motor shall include the necessary parameters and conditions required for use with a convertor.

NOTE Additional information on the application of convertor-fed motors can be found in IEC 60034-17 and IEC 60034-25. Major concerns include over-temperature, high frequency and over-voltage effects, bearing currents and requirements for high frequency earthing.

8.10.2.3 Alternative type test by calculation

Alternatively to the type test of 8.10.2.2, the temperature class may be determined by calculation. In cases where the temperature class is determined by calculation, the calculation shall be based on previously established representative test data and in accordance to IEC 60034-25.

NOTE 1 The determination of the temperature class by calculation should be agreed between the manufacturer and the user as appropriate.

NOTE 2 The temperature differential between stator and rotor of a machine operating with a non-sinusoidal supply, or generating into a thyristor load, may vary greatly from the temperature differential that would occur in the same machine operating with a sinusoidal supply, or generating into a linear load. Therefore special attention needs to be paid to the rotor temperature which may be a limiting feature of the machine, particularly in the case of rotor cage windings.

9 Supplementary requirements for non-sparking fuses and fuse assemblies

9.1 Fuses

Fuses shall be deemed non-sparking devices if they are non-rewirable, non-indicating cartridge types or indicating cartridge types, according to IEC 60269-3, operating within their rating.

NOTE 1 Rupture of the fuse is not considered to be normal operation.

NOTE 2 The basis of compliance should be stated in the documentation provided in accordance with Clause 25. If certification (third party) is sought, it is not a requirement of this standard that the certification body confirm conformance to IEC 60269-3.

9.2 Temperature class of equipment

The temperature class of equipment shall consider the external surface of the cartridge, including the indicator if any, of each fuse mounted in the equipment based on the rated current of the equipment.

In the case of multiple sources of heat, a diversity factor may be applied in which case it shall be stated in the documentation (see Clause 25).

9.3 Fuse mounting

Fuse shall be mounted in non-sparking enclosed holders or non-sparking spring holders or shall be soldered in place. Fuse holder connections shall be in accordance with 7.3.5.

9.4 Fuse enclosures

Enclosures containing fuses shall be interlocked so that the fuses can only be removed or replaced with the supply disconnected. Alternatively, the enclosure shall carry the warning given in item a) of Table 14.

9.5 Replacement fuse identification

Unless the fuses are of a non-interchangeable type, provision shall be made for the correct type and value for replacement fuses to be marked adjacent to the fuse holders.

10 Supplementary requirements for non-sparking plugs and sockets

10.1 Plugs and sockets for external connections

Plugs and sockets for external connections shall comply with either item a), b) or c) as follows:

- a) they shall be interlocked mechanically or electrically, or otherwise designed so that they cannot be separated when the contacts are energized and the contacts cannot be energized when plug and socket are separated. Switches used for this purpose shall comply with this standard or with one or more types of protection listed in IEC 60079-0;

- b) if they are allocated and connected to only one part of the equipment, they shall be secured mechanically to prevent unintentional separation and the equipment shall be marked with the warning given in item b) of Table 14.
- c) All of the following:
- the part which remains energized is a socket outlet;
 - the plug and socket break the rated current with delayed release to permit the arc to be extinguished before separation;
 - the plug and socket remain flameproof according to IEC 60079-1 during the arc quenching period;
 - the contacts remaining energized after separation are protected according to one of the specific types of protection with equipment protection level Ga, Gb or Gc, listed in IEC 60079-0.

10.2 Maintaining degree of protection (IP code)

Provision shall be made for the fixed part of a plug and socket connector to maintain the degree of protection of the enclosure on which it is mounted, even when the movable part has been removed. If the degree of protection is effectively reduced by accumulation of dust or water, provision shall also be made for maintaining an appropriate degree of ingress protection for the plug and/or socket.

10.3 Sockets that do not have plugs inserted in normal operation

Sockets within equipment which in normal operation do not have a plug inserted and which are used only for maintenance and repairing, are deemed to be non-sparking.

11 Supplementary requirements for non-sparking luminaires

NOTE Portable luminaires should also comply with the relevant requirements of this clause.

11.1 General

Lamps with internal ignitors can cause uncontrolled voltages which can damage ballasts or electronic ignitors. Such lamps shall not be specified for use with luminaires having type of protection "n" unless special precautions are taken to limit possible damage to auxiliaries.

NOTE 1 If certification (third party) is sought, it is not a requirement of this standard that the certification body confirm conformance to IEC 60598-1, IEC 60598-2, IEC 61184, IEC 60238, IEC 60400, IEC 61347-1, IEC 61347-2-1, IEC 61347-2-2, IEC 61347-2-3, IEC 61347-2-4, IEC 61347-2-7, IEC 61347-2-8, IEC 61347-2-9, IEC 61048, IEC 60155, IEC 60927, and IEC 60998-2-4. The manufacturer should state the basis of compliance in the documentation, see Clause 25.

NOTE 2 In order to reduce the time of testing and to allow for any tests that may be destructive, the tests may be performed on additional luminaires or parts of luminaires, provided that these are in the same materials as the original sample and the results of the test are considered to be the same as if carried out on a single sample.

11.2 Construction

11.2.1 General

For fluorescent tubes, the distance between the lamp and a protective cover shall be not less than 5 mm unless the protective cover is a concentric cylindrical tube, in which case the minimum distance is 2 mm. For other lamps, the distance between the lamp and the protective cover shall be not less than the value given in Table 7 according to the lamp wattage

Table 7 – Minimum distance between lamp and protective cover

Lamp wattage, <i>P</i> <i>W</i>	Minimum distance mm
$P \leq 60$	3
$60 < P \leq 100$	5
$100 < P \leq 500$	10
$500 < P$	15

11.2.2 Enclosure of lamp

The whole of the lamp(s) shall be enclosed within the light transmitting cover as part of the luminaire.

11.2.3 Lampholders

11.2.3.1 General

Lampholders, in addition to complying with the safety and interchangeability requirements of the relevant standard, shall be of the non-sparking type according to 11.2.3.2, 11.2.3.3 and 11.2.3.4.

NOTE Normal operation does not include the removal and insertion of lamps when their circuits are energized.

11.2.3.2 Bayonet non-sparking lampholders

Bayonet non-sparking lampholders shall comply with the requirements of IEC 61184. They shall incorporate spring contacts so designed that the springs are not the principal means of carrying the current.

The connecting wires and their insulation shall not be damaged when the lamp is inserted or removed. The lampholder shall be of a type designed to prevent sparking under conditions of vibration. The spring elements used shall ensure a contact force of at least 10 N between lampcap and lampholder.

11.2.3.3 Screw non-sparking “nA” lampholders

Screw non-sparking lampholders shall comply with the safety and interchangeability requirements of IEC 60238 when mounted in the luminaire. Screw lampholders shall prevent self-loosening of the lamp after insertion. For lamp caps other than E10, this shall be shown by meeting the mechanical test of 22.7. The lampholder shall be of a type designed to prevent sparking under conditions of vibration. The spring elements used shall ensure a contact force of at least 10 N between lampcap and lampholder.

NOTE The threaded part of the lampholder should be of material which is resistant to corrosion under the likely conditions of service.

11.2.3.4 Bi-pin non-sparking lampholders

Bi-pin non-sparking lampholders shall comply with the safety and interchangeability requirements of IEC 60400 when mounted in the luminaire. They shall also be designed to make and maintain contact on the barrels of the lamp pins. Contact pressures shall be adequate and the pins of the lamp shall be supported to prevent distortion when they are subject to contact side pressure. The mechanical dimensions and the mounting conditions in the luminaire shall take into account the mechanical values and the tolerances specified for

the lamp in IEC 60061-1, IEC 61195 and IEC 60400. The lampholder shall be of a type designed to prevent sparking under conditions of vibration.

NOTE This can be shown by the complete luminaire meeting the vibration test for rough service luminaires in IEC 60598-1 using the test arrangement as given in IEC 60079-7.

11.2.4 Auxiliaries

11.2.4.1 General

When mounted in the luminaire, auxiliaries shall comply with the electrical and mechanical safety requirements of IEC 61347-1, IEC 61347-2-1, IEC 61347-2-2, IEC 61347-2-3, IEC 61347-2-4, IEC 61347-2-7, IEC 61347-2-8, IEC 61347-2-9, IEC 61048 and IEC 60155, as applicable, or of other appropriate standards.

Auxiliaries outside of the scope of the above standards shall be constructed in accordance with this standard or other protection standards. Where required they shall be additionally subject to the tests in this standard.

Auxiliaries within the scope of the above standards are not required to comply with the requirements of IEC 60079-0 for non metallic materials on which the type of protection depends. Where the manufacture of the auxiliary is not controlled by the luminaire manufacturer the documentation shall define the construction of the auxiliary sufficiently to ensure that requirements of this standard are complied with.

11.2.4.2 Glow-type starters

Glow-type starters shall be of the type in which the contacts are enclosed in a hermetically-sealed envelope (for example, glass bottle inside a metal or plastics enclosure; the enclosure does not have to be hermetically sealed).

11.2.4.3 Electronic starters and ignitors

Electronic starters and ignitors shall have a starting pulse voltage not exceeding 5 kV and shall comply with the safety and performance requirements of IEC 61347-2-1 and IEC 60927, respectively. They shall be non sparking devices and meet the requirements of 22.9. If the case is made of metal, it shall be bonded to the earth terminal of the luminaire. Electronic starters and ignitors that are sealed, potted or moulded in a case shall additionally comply with the relevant requirements specified in 22.9 and with the relevant requirements of 22.5.

Ignitors shall be subject to the endurance test in 22.9.4.1.

NOTE 1 The requirements of 22.5 and 22.9 are additional to those in the auxiliary standards. Electronic starters or ignitors which are neither encapsulated nor sealed should be assessed in accordance with the relevant clauses of this standard.

NOTE 2 Whether or not the starter is fitted with a cut-out device will influence the temperature classification (see 22.9).

NOTE 3 Luminaire auxiliaries need not meet the requirements of IEC 60079-18.

11.2.4.4 Starter holders

Starter holders shall be of the non-sparking type and shall comply with the safety and interchangeability requirements of IEC 60400 when mounted in the luminaire.

Both starter and holder shall be mounted within the enclosure in such a way that the assembly is adequately supported to prevent movement that could give rise to sparking under conditions of vibration.

In particular, contacts shall be resilient and shall provide adequate contact pressure.

Compliance shall be checked by the test specified in 22.8.

11.2.4.5 Ballasts

The limiting temperature of ballasts, lampholders and lamps shall not be exceeded even in the case of aged lamps. The luminaire shall be subjected to the thermal tests of IEC 60079-0. The stabilized temperature of the ballast, lampholder, and the lamp itself shall be less than the limiting temperature, or a cut-off device shall be used to switch off the power before the limiting temperature is exceeded. Resetting of the cut off device shall only be possible manually (e.g. by switching off the power for resetting).

Ballasts which are used with ignitors that have a working voltage above 1,5 kV shall be of the following construction:

- in accordance with IEC 61347-2-8 and IEC 61347-2-9;
- not be of the type which can only be used with ignitors having a timed cut-out.

Ballasts subjected to only the 30 day voltage impulse type test shall only be used with timed cut-out ignitors.

If ignitors without timed cut-out are used, the voltage impulse test in IEC 61347-2-8 and IEC 61347-2-9 shall be run for 60 days.

Electronic ballasts according to IEC 61347-2-3, IEC 61347-2-4, IEC 61347-2-7, shall not produce temperatures in excess of the temperature class when subjected to the abnormal conditions given in those standards.

If the ballast is not protected by an internal over current device on the printed circuit boards of electronic ballasts, the requirements for creepage and clearance distances in Table 3 of IEC 61347-1 apply without the exemptions permitted in that standard. If such an over current device is used the creepage and clearance distances on the supply side of the over current device shall be in line with Table 2. The over current device, if employed, shall have a rated voltage not less than that of the circuit and shall have a breaking capacity not less than the fault current of the circuit.

NOTE The rating of the fuse selected should reflect the current of the ballast in normal operation, inrush impulses as well as the EMC stresses (e.g. surge).

11.2.5 Creepage distances and clearances

With exception of the supply terminals for which the creepage and clearance of Table 2 apply, the creepage distance and clearance requirements of the relevant clause of IEC 60598 shall apply.

In addition, where circuits include ignitors that can subject lamps, lampholders and other components to high-voltage impulses in excess of 1,5 kV peak, the relevant minimum creepage distances and clearances shall comply with Table 8.

Table 8 – Creepage distances and clearances at peak values of pulse voltages greater than 1,5 kV

Part	Peak pulse voltages V_{pk}			
	kV		kV	
	Above 1,5 and up to 2,8	Above 2,8 and up to 5,0	Above 1,5 and up to 2,8	Above 2,8 and up to 5,0
	Creepage mm		Clearances mm	
Lamp cap	4	6	4	6
Inside parts of lampholders	6	9	4	6
External parts of lampholders		12	6	9
Other built-in components ^a that are subject to the pulsed voltage of the ignitor	8	12	6	9

^a Unless the component itself is an encapsulated device or a sealed device.

11.2.6 Terminals

11.2.6.1 Looping connections

For luminaires with more than one cable or conduit entry where the entries are to be used for looping the supply and earthing conductors the looping connections shall be provided.

11.2.6.2 Screw type lampholder polarity

Where a screw-type lampholder is used, the centre contact of the lampholder shall be connected directly or indirectly to the live terminal of the supply connection in the luminaire.

11.2.7 Internal wiring

Internal wiring shall be chosen and applied in accordance with temperatures and voltages that may be encountered. Where circuits include ignitors that subject some internal wiring to high-voltage impulses, such wiring shall be chosen so that the insulation is satisfactory for such impulses, which is shown by meeting the electric strength test of 22.10.

11.3 Luminaires for tubular fluorescent bi-pin lamps

11.3.1 General

Luminaires for tubular fluorescent bi-pin lamps shall additionally comply with the following requirements.

11.3.2 Maximum ambient temperature

The maximum ambient temperature for a luminaire with tubular fluorescent bi-pin lamps employing an electronic ballast shall not exceed 60 °C.

NOTE This limitation is to achieve a T4 temperature class even under the end of life conditions for the lamp.

11.3.3 Temperature class

As the limiting temperature of a luminaire with tubular fluorescent bi-pin lamps employing an electronic ballast can exceed the temperatures appropriate for temperature classes T5 and T6, those temperature classes shall not be permitted.

NOTE If it can be demonstrated that an electronic ballast can detect the end of life condition and so limit the maximum surface temperature then T5 and T6 temperature classes may be possible. Luminaires for fluorescent lamps normally have a T4 temperature class.

11.3.4 Endurance tests and thermal tests

11.3.4.1 General

The endurance and thermal test requirements of the relevant part of IEC 60598-2 shall apply together with the requirements specified in 11.3.4.2 to 11.3.4.4.

11.3.4.2 Thermal test (normal operation)

When tested in accordance with 12.4 of IEC 60598-1, the temperatures shall not exceed the values shown in Tables 12.1 and 12.2 of that standard.

11.3.4.3 Thermal test (abnormal conditions)

11.3.4.3.1 Temperatures except for windings

Except for windings (see 11.3.4.3.2), the temperatures shall not exceed the values given in 12.5 of IEC 60598-1 under conditions representing abnormal service conditions (where applicable but not representing a defect in the luminaire or misuse) using a test voltage of:

- a) for filament lamp luminaires, 1,10 times the voltage that would provide rated power;
- b) for tubular fluorescent and other discharge lamp luminaires, 1,10 times the rated voltage;
- c) for luminaires containing electronic ballasts and similar devices, that value between 0,90 and 1,10 times the rated voltage which produces the most onerous condition.

11.3.4.3.2 Temperatures for windings

For windings, the values in Table 12.3 of IEC 60598-1 for the maximum temperature of a winding shall be reduced by 20 °C.

The temperature of windings of ballasts containing thermal protective devices may exceed these temperatures by up to 15 K for 15 min, prior to operation of the protective device.

11.3.4.3.3 Tests for luminaires containing electronic ballasts

The requirements of the relevant subclause of IEC 61347-2-3 shall apply together with following modifications:

- the asymmetric pulse test and the asymmetric power dissipation test shall be conducted;
- for T8, T10, and T12 lamps, the maximum cathode power observed during the tests shall not exceed 10 W, for T4 lamps, the power shall not exceed 3 W and for T5 lamps, shall not exceed 5 W.

NOTE 1 The temperature used for the test is the standard ambient temperature in the laboratory (23 ± 2) °C.

NOTE 2 The limits for the power dissipation in cathodes of lamps supplied by electronic ballasts limits were derived from experimental data on luminaires operated in an ambient temperature of 60 °C and with a temperature class of T4.

NOTE 3 It is recognized that electronic ballasts can overdrive lamps creating very hot surfaces near the cathodes in a way not possible using simple reactive ballasts.

11.3.4.4 Surface temperatures

11.3.4.4.1 Luminaires

Under both normal and specified regular expected conditions, the surface temperature of any internal part of the luminaire, or the external surface of the luminaire, shall not exceed either the temperature class or the maximum specified surface temperature.

The maximum surface temperature prescribed by IEC 60079-0 may be exceeded at the lamp when the highest surface temperature of the lamp inside the luminaire is at least 50 K below the lowest temperature of ignition inside the luminaire of the explosive atmosphere for which the luminaire is intended, as determined by tests made in an explosive gas atmosphere under the most unfavourable conditions of use. No ignition of the surrounding atmosphere shall occur. This dispensation is only valid for the explosive gas atmospheres indicated on the certificate, these being those for which the tests have given satisfactory results.

NOTE Measurements on existing luminaires have established that the temperatures at which ignition will occur inside the luminaires are considerably higher than the ignition temperatures measured in accordance with IEC 60079-4.

11.3.4.4.2 Illuminated surfaces

For spotlights and the like, the distance at which a surface illuminated by the luminaire exceeds the declared temperature class or the declared maximum surface temperature shall be determined according to the test in IEC 60598-1. If this distance exceeds 0,3 m, it shall be marked on the luminaire.

11.3.5 Resistance to dust and moisture

The resistance to dust and moisture requirements of the relevant clause of IEC 60598-2 shall apply.

In addition, luminaires shall have a minimum degree of protection of IP54, which shall be marked in accordance with Clause 24.

NOTE The degree of protection requirements from IEC 60598-1 are not used.

11.3.6 Insulation resistance and electric strength

The provisions of the relevant section of IEC 60598-2 shall apply.

11.4 Other equipment containing light sources

Light sources mounted within other equipment shall comply with the relevant requirements of Clause 11.

12 Supplementary requirements for equipment incorporating non-sparking cells and batteries

12.1 General

The requirements for cells and batteries incorporated into equipment of IEC 60079-0 apply as modified by 12.2 to 12.6.

12.2 Categorization of cells and batteries

12.2.1 General

Cells and batteries are type categorized according to the likelihood of the evolution of electrolytic gases (for example hydrogen and/or oxygen). This standard places restrictions on the use of cells and batteries according to their type, see Table 9.

12.2.2 Type 1 cells and batteries

Type 1 cells and batteries are those which are most unlikely to vent electrolytic gases under the envisaged conditions of use.

These include all primary cells and sealed secondary cells where the operating parameters are within the manufacturer's recommended limits and the control system is either contained in the equipment or defined in the equipment documentation in such a way as to give equivalent control. These types of cells or batteries may be used in type "n" equipment without additional precautions.

The technical requirements and special precautions are given in 12.3 and 12.4 and the verification and tests in 12.6.

12.2.3 Type 2 cells and batteries

Type 2 cells and batteries are those which are unlikely to vent electrolytic gas in normal operation but may do so under uncontrolled conditions.

These sealed valve regulated cells and sealed gas-tight cells, where the manufacturer's recommended limits and the control system are not fully specified in accordance with the manufacturer's requirements, may be used in type "n" equipment which does not contain parts which in normal operation produce arcs or sparks, as considered in Clauses 16 to 20.

It is, however, acceptable to incorporate these cells or batteries in such equipment provided that they are in a separate compartment, vented directly to the atmosphere external to the enclosure. When using these cells or batteries special precautions shall be taken into account.

The technical requirements and special precautions are given in 12.3 and 12.4 and the verification and tests are given in 12.6.

12.2.4 Type 3 cells and batteries

Type 3 cells and batteries are those which are capable of venting electrolytic gas in normal operation.

These types of cells and batteries shall be designed to avoid accumulation of gas in the compartments by directly venting them to the atmosphere external to the enclosure. The compartments shall contain no other electrical parts except those necessary to make the connections to the cells and batteries.

The technical requirements and special precautions are given in 12.5 and the verification and tests are given in 12.6.

Table 9 – Types and use of cells and batteries

Type of cell or battery	Capacity of cell or battery	Permitted activity in hazardous area			Remarks
		Discharging	Charging of secondary cells	Additional equipment in the same compartment	
1	≤ 25 Ah	Yes	Yes	Yes	–
2	≤ 25 Ah	Yes	No ^a	Yes Only equipment without arcs or sparks	Equipment with sparks or arcs shall be located in a separate compartment
3	No restriction	Yes	No ^a	No	–

^a For charging in hazardous areas, special precautions are required.

12.3 General requirements for cells and batteries of types 1 and 2

12.3.1 General

The requirements for cells and batteries incorporated into equipment of IEC 60079-0 apply as modified by 12.3.2 to 12.3.15.

12.3.2 Maximum capacity

The maximum capacity of the cell or battery shall not exceed 25 Ah at the rated discharge time declared by the manufacturer.

12.3.3 Secondary cells

Secondary cells or batteries shall not be used in equipment designed for primary cells or batteries or vice versa unless the equipment is designed specifically for use with both.

12.3.4 Cell connection

Cells shall be connected in series except for the specific case where two cells are connected in parallel with no further cells connected in series.

12.3.5 Discharge mode

Cells and batteries in discharge mode shall be used as specified by the cell or battery manufacturer.

12.3.6 Temperature

The temperature of the cell container shall not exceed the value specified by the manufacturer.

12.3.7 Creepage and clearance

Creepage and clearance distances between the poles of a cell to normal industrial cell and battery standards are permissible.

12.3.8 Connections

The electrical connections between cells and batteries shall comply with Clause 6 and be of a type recommended by the manufacturer of the cell or battery to ensure there is no excessive stress to the cell or battery.

12.3.9 Connecting cells in series

No more than three cells shall be connected in series, unless precautions are taken to prevent reverse polarity charging of the cell.

NOTE The actual capacity of a cell may be reduced with time. If this occurs, cells of higher actual capacity may cause cells of lower capacity to reverse.

12.3.10 Deep discharge protection

If a deep discharge protection is installed to prevent reverse polarity charging of cells, the minimum cut-off voltage shall comply with the cell manufacturer's specification.

NOTE Generally, a maximum of six cells can be protected by one deep discharge protection circuit. If too many cells are connected in series, there may be no safe protection due to the tolerances of individual cell voltages and of the deep discharge protection circuit.

12.3.11 Temperature test conditions

For verification and test of the temperature rating, the highest discharge current in normal operation shall be taken into account.

12.3.12 Battery packs

Secondary cells or batteries shall be securely connected and assembled as a battery-pack.

NOTE This prevents faulty connections, connections of cells with different status of charge or different age.

12.3.13 Battery pack connections

If the battery pack is not an integral part of the equipment, precautions shall be taken to safeguard against incorrect connections between the battery pack and the charger.

NOTE Suitable precautions include polarized plugs and sockets or clear marking to indicate correct assembly.

12.3.14 Cell electrolyte and gas release

If electrolyte can be ejected from cells under specified regular expected conditions, provision shall be made to prevent contamination of live parts. Cells and batteries without gas release under specified regular expected conditions do not need protection.

12.3.15 Excessive load draw

If during discharging an excessive load drawn from the cell or battery can cause damage to the cell or battery affecting the type of protection "n", the maximum load or a safety device shall be specified.

12.4 Charging of type 1 and type 2 cells and batteries

12.4.1 Temperature range

The design of the charger shall take into account the ambient temperature range in which the equipment is designed to work.

12.4.2 Charger specifications

If cells and batteries which are an integral part of the electrical equipment are to be charged in the hazardous area, the charger shall be fully specified as part of the equipment design.

12.4.3 Charging separated cells or batteries

Separated cells or batteries shall not be charged inside the hazardous area.

12.4.4 Charger limitations

The charging system shall be designed such that in normal operation the charge voltage and current do not exceed the limits specified by the manufacturer based on the specified temperature range of the equipment.

12.4.5 Charging outside the hazardous area

If cells or batteries which are an integral part of the electrical equipment or can be separated from the equipment are charged outside of the hazardous area, the charging shall be within the limits specified by the manufacturer of the equipment.

12.4.6 Gassing during charging of type 2 cells or batteries

The charging system should not normally cause gassing. However, if gassing does occur, the construction of the battery container shall be such that the H₂ level in it shall not exceed 2 % V/V after 48 h.

The test to verify this shall be that a H₂ concentration of greater than 2 % V/V shall be reduced to 2 % V/V in not more than 48 h by natural dissipation in still air at a constant temperature.

12.5 Requirements for type 3 secondary batteries

12.5.1 Types of permissible batteries

Type 3 secondary batteries shall be of the lead-acid, nickel-iron, nickel-metal hydrides or nickel-cadmium type. The capacity of type 3 secondary batteries is not restricted. For liquid filled monobloc batteries typically used for internal combustion engine starting or small standby applications, the relevant clauses and design principles shall be applied but connection arrangements can be appropriate to the method of construction in a unit.

The tests and verification are given in 12.6.

NOTE Compliance with these requirements does not ensure safety during charging. Charging should therefore take place outside the hazardous area, unless other safety measures are applied.

12.5.2 Battery containers

12.5.2.1 Internal surfaces

Internal surfaces shall not be adversely affected by the action of the electrolyte.

12.5.2.2 Mechanical requirements

Battery containers, including covers, shall be designed so as to withstand the mechanical stresses in use, including those due to transit and handling. The design shall protect against causing short-circuits in service.

12.5.2.3 Creepage distances

The creepage distance between the poles of adjacent cells and between these poles and the battery container if metallic and conducting shall be at least 35 mm. For non-metallic enclosure, the creepage distances shall comply with Table 2. Where nominal voltages between adjacent cells of the battery exceed 24 V, these creepage distances shall be increased by at least 1 mm for every 2 V in excess of 24 V.

12.5.2.4 Covers

The covers of battery containers shall be fixed in such a way that any inadvertent opening or displacement while in service is avoided.

12.5.2.5 Cell assembly

The assembly of cells shall be constructed in such a way that there is no significant displacement in service.

12.5.2.6 Liquid extraction

The extraction of liquid, which may have entered battery containers that do not have drain holes, shall be possible without the removal of the cells.

12.5.2.7 Ventilation

The battery container shall be provided with adequate ventilation. A degree of protection of IP23 according to IEC 60529 is sufficient for a battery container.

12.5.2.8 Plugs and sockets

Plugs and sockets shall comply with the requirements of Clause 10. This does not apply to plugs and sockets which can only be separated with the use of a tool and which bear the warning given in item c) of Table 14. Where there are single-pole positive and negative plugs and sockets, they shall not be interchangeable.

12.5.2.9 Polarity marking

The polarity of the battery connections and of plugs and sockets shall be marked clearly in a durable manner.

12.5.2.10 Other equipment

Any other electrical equipment affixed to or incorporated in the battery container shall comply with the relevant requirements of this standard.

12.5.2.11 Insulation resistance

New batteries, fully charged and ready for service, shall have an insulation resistance of at least 1 M Ω between the live parts and the battery container.

12.5.3 Cells

12.5.3.1 Lids

The cell lid shall be sealed to the cell container so as to prevent detachment of the cell lid and leakage of the electrolyte. Readily ignitable materials shall not be used.

12.5.3.2 Support

The positive and negative plates shall be supported to prevent movement.

12.5.3.3 Electrolyte maintenance

Each cell requiring maintenance of the electrolyte level shall be provided with a means of indicating that the electrolyte level lies between the minimum and maximum permissible levels. Precautions shall be taken to avoid excessive corrosion of the plate lugs and the busbars when the electrolyte is at the minimum level.

12.5.3.4 Expansion space

In each cell sufficient space shall be provided to prevent the cell overflowing due to expansion of the electrolyte and also for deposition of slurry where this is likely to occur. These spaces shall be related to the anticipated life of the battery.

12.5.3.5 Filling and vent plugs

Filling and vent plugs shall be designed to prevent any ejection of the electrolyte under normal conditions of use. They shall be located in such a manner that they are easily accessible for maintenance.

12.5.3.6 Electrolyte seals

A seal shall be provided between each pole and the lid of the cell to prevent leakage of the electrolyte.

12.5.4 Connections

12.5.4.1 Intercell connections

The intercell connectors between cells that can move relative to one another shall be non-rigid. When non-rigid connections are used, each end of the connection shall be

- a) welded or soldered into the terminal post, or
- b) crimped into a copper sleeve cast into the terminal post, or
- c) crimped into a copper termination screwed by a threaded fastening to a copper insert cast into the cell terminal post.

In cases b) and c), the conductor shall be copper. In case c), the effective contact area between the termination and the cell terminal post shall be at least equal to the conductor cross-section. In calculating the effective contact area, no account shall be taken of the area of male and female threads in contact.

NOTE Although the word "copper" is used in item c) above, copper alloyed with a small amount of another metal (for example chromium or beryllium) is acceptable where it is necessary to improve the mechanical properties of the connection (for example to prevent stripping of screw threads in the copper insert). Where such alloys are used, it may be necessary to increase the contact area of the inter-cell connection to counteract any decrease in electrical conductivity caused by the other metal.

12.5.4.2 Temperature assessment

The connectors and terminations shall be able to carry the current required for the application without exceeding the temperature class. Where the application is not specified, the battery shall be assessed at the 1 h discharge rate specified by the battery manufacturer.

12.5.4.3 Connector protection

All connectors susceptible to attack by the electrolyte shall be protected from corrosion.

12.6 Verification and tests

NOTE These type tests apply to batteries to which the additional requirements of 12.5 apply.

12.6.1 Insulation resistance

The test conditions are given in 22.12.

12.6.2 Mechanical shock test

Batteries which are subject to mechanical shocks in normal service, for example large lead acid batteries used in lift trucks, shall be submitted to the test of 22.11. Other batteries need not be submitted to this test but this shall be noted in the descriptive documentation. The test shall be carried out only on samples of cells and their connections. Where cells of similar construction are foreseen in a range of capacities, it is not necessary to test every capacity, but only a sufficient number to allow assessment of the behaviour of the complete range.

13 Supplementary requirements for non-sparking low power equipment

Electronic and allied low power equipment, assemblies and sub-assemblies with a rated voltage up to 275 V a.c. or 390 V d.c. used for example, for measurement, control or

communication purposes, used in an area of not more than pollution degree 2, as defined in IEC 60664-1, and which do not comply with 6.4 and 6.5.2 shall comply with the following.

- a) The enclosure for the equipment shall provide a degree of protection not less than IP54 in accordance with IEC 60529 unless the equipment is intended to be afforded an equivalent degree of protection by location.

NOTE The order of tests including IP 54 is given in Clause 21.

- b) If the rated voltage of the equipment or the working voltage of any part of the equipment being considered does not exceed 60 V a.c. or 85 V d.c., no minimum creepage and clearance requirements are specified. Equipment with a rated voltage of over 60 V a.c. or 85 V d.c. up to 275 V a.c. or 390 V d.c. shall comply with the creepage and clearance requirements in Table 10.
- c) Provision shall be made, either in the equipment or external to the equipment, to provide the transient protection device to be set at a level not exceeding 140 % of the peak rated voltage value of 85 V or of the peak rated voltage values at the power supply terminals of the equipment given in Table 10. The transient protection shall limit transients up to a maximum of 140 % of the peak voltage values for the steps given in Table 10 that the equipment falls into, determined by the maximum input voltage of the equipment in normal operation. Where the equipment is intended to be afforded an equivalent degree of protection by location or where transient protection is to be provided externally, the equipment shall be marked with the symbol "X" (see the marking requirements of IEC 60079-0) and the information shall be given in the documentation (see Clause 25).

NOTE 1 Low power is considered to be typically less than or equal to 20 W.

NOTE 2 Non-sparking low power equipment circuits may be included in assemblies and sub-assemblies that comply with 6.4 provided the separations between the non-sparking low power equipment circuits and all other circuits meet the requirements of 6.4.

Table 10 – Minimum creepage distances, clearances and separations for low power equipment

Peak voltage value (Note 1) V	Minimum creepage distance (Note 2) mm			Minimum clearances and separation mm		
	Material group			In air	Under coating (Note 3)	Encapsulated or solid insulation (Note 4)
	I	II	III			
90	0,63	0,9	1,25	0,4	0,3	0,15
115	0,67	0,95	1,3	0,4	0,4	0,3
145	0,71	1	1,4	0,4	0,4	0,3
180	0,75	1,05	1,5	0,5	0,4	0,3
230	0,8	1,1	1,6	0,75	0,55	0,3
285	1	1,4	2	1	0,85	0,3
355	1,25	1,8	2,5	1,25	0,85	0,3

NOTE 1 The actual working voltage may exceed the value given in the table by up to 10 %.

NOTE 2 Values for creepage distances are derived from IEC 60664-1 based on pollution degree 2.

NOTE 3 Under a conformal coating, see 6.4.3.

NOTE 4 Completely encapsulated in compound to a minimum depth of 0,4 mm, or separation through solid insulating material, for example the thickness of a printed wiring board.

NOTE 5 For printed circuit boards mounted in clean dry conditions as defined in IEC 60664-1, the minimum creepage distances can be reduced to the values of the clearances and separation.

14 Supplementary requirements for non-sparking current transformers

Where the secondary circuit of a current transformer extends outside the equipment, the descriptive documents shall draw attention to the need to guard against the secondary circuit becoming open circuited in service.

NOTE If current transformers are fitted, under open-circuit secondary conditions, they may be capable of producing voltages which are significantly in excess of the voltage rating of the terminals employed in the current transformer circuit. Dependent on the circumstances of a particular installation, it may be appropriate to take precautions to ensure that dangerous open-circuit voltages cannot occur. For equipment having current transformers connected to matching transformers in the switchgear (for example a differential protection system), consideration should be given to the effect on the equipment of any possible disconnection of either set of transformers.

15 Other non-sparking electrical equipment

Electrical equipment which is not specifically mentioned in Clauses 8 to 14 shall comply with the requirements in Clauses 4 to 9 together with any relevant requirements of Clauses 8 to 14.

16 General supplementary requirements for equipment producing arcs, sparks or hot surfaces

Parts which in normal operation produce arcs, sparks or hot surfaces which otherwise would be capable of igniting a surrounding atmosphere shall be protected against causing ignition by one or more of the following methods:

- a) enclosed-break device (see Clause 17);
- b) non-incendive component (see Clause 17);
- c) hermetically sealed device (see Clause 18);
- d) sealed device (see Clause 19);
- e) restricted-breathing enclosure (see Clause 20).

Parts of the equipment may alternatively be protected by another appropriate type of protection listed in IEC 60079-0, in which case the equipment marking shall include the symbol for that type of protection.

17 Supplementary requirements for enclosed-break devices and non-incendive components producing arcs, sparks or hot surfaces

17.1 Type testing

Enclosed-break devices and non-incendive components shall be subjected to the type test specified in 22.4. After the test, the device or component shall show no visible signs of damage, no external ignition shall occur, and there shall be no failure to clear the arc when the switch contacts are opened.

17.2 Ratings

17.2.1 Enclosed-break devices

Enclosed-break devices shall be limited to a maximum rating of 690 V a.c., r.m.s. or d.c. and 16 A a.c. r.m.s. or dc.

NOTE An enclosed-break device prevents flame transmission to the external atmosphere under the test conditions of 22.4 by the closeness of fit of its parts which, because of the construction, form an assembly that prevents external ignition of the explosive mixture.

17.2.2 Non-incendive components

Non-incendive components shall be limited to a maximum rating of 254 V a.c., r.m.s. or d.c. and 16 A a.c., r.m.s. or d.c.

NOTE The contact arrangements of a non-incendive component quench an incipient flame and thereby prevent ignition of an external explosive atmosphere from occurring. The use of non-incendive components is limited to circuits having electrical characteristics which are similar to those of the circuit of which the components were a constituent when tested, or to less dangerous circuits, in terms of voltage, current, inductance or capacitance, for example.

17.3 Construction of enclosed-break devices

17.3.1 Free internal volume

The free internal volume shall not exceed 20 cm³.

17.3.2 Continuous operating temperature (COT) requirements

Poured seals and encapsulating compounds shall have a continuous operating temperature (COT) at least 10 K higher than the maximum service temperature.

17.3.3 Seal protection

Enclosures shall be capable of withstanding normal handling and assembly operations without damage to seals.

18 Supplementary requirements for hermetically sealed devices producing arcs, sparks or hot surfaces

Hermetically sealed devices are considered as meeting the requirements for sealed devices without test.

NOTE A leakage rate equivalent to a He-leakage rate less than 10⁻² Pa·l/s (10⁻⁴ mbar·l/s) at a pressure difference of 10⁵ Pa (1 bar) is sufficient.

The enclosure shall be capable of withstanding normal handling and assembly operations without damage to the seal.

19 Supplementary requirements for sealed devices producing arcs, sparks or hot surfaces

19.1 Non-metallic materials

Seals are tested using 22.5 unless the non-metallic material forms all or part of the outer enclosure of the equipment. In this case the requirements of 22.3.1.1 apply

19.2 Opening

Sealed devices shall be so constructed that they cannot be opened in normal operation.

19.3 Internal spaces

Sealed devices shall have a free internal volume not exceeding 100 cm³, and shall be provided, where necessary, with external connections, for example flying leads or external terminals.

19.4 Handling

The device shall be capable of withstanding normal handling and assembly operations without damage.

19.5 Gasket and seals

Gasket and seals, including poured seals, shall be positioned so that they are not subject to mechanical damage under normal operating conditions and they shall retain their sealing properties over the expected life of the device. They shall have a continuous operating temperature (COT) at least 10 K higher than the service temperature. Where the device is for use in a luminaire, the COT shall be at least 20 K higher than that occurring when operating in the most onerous rated service conditions.

19.6 Type tests

The type tests described in 4.2.5 shall be performed.

20 Supplementary requirements for restricted-breathing enclosures protecting equipment producing arcs, sparks or hot surfaces

20.1 General

Restricted breathing equipment shall be limited in dissipated power such that the temperature measured on the outside does not exceed the maximum surface temperature requirements of IEC 60079-0.

Restricted breathing enclosures shall only be assessed as complete equipment including all options and accessories.

NOTE 1 Equipment should be provided with a test port to enable testing of restricted breathing properties to be carried out after installation and during maintenance. See also information given in 20.2.7

NOTE 2 The installation instructions provided with the equipment should contain information on the selection of either cable glands and cables or conduit entry devices.

NOTE 3 The effects of the sun's direct heating and other sources of heating or cooling on the enclosure should be taken into account.

NOTE 4 The use of a restricted-breathing enclosure to protect against ignition from sparking contacts is not advisable where, because of high internal air temperatures, there is an increased risk of drawing the hazardous atmosphere into the enclosure when the equipment is de-energized. Duty cycle of this type of equipment should also be considered because of the increased probability that the equipment might be de-energized when flammable gas or vapour surrounds the enclosure

20.2 Constructional requirements

20.2.1 Type of equipment

20.2.1.1 Equipment containing normally sparking devices

Restricted breathing equipment containing normally arcing or sparking devices, or equipment with hot surfaces designed to have frequent temperature cycles, shall be limited in dissipated power such that the temperature measured on the outside of the enclosure does not exceed the external ambient temperature by more than 20 K.

The requirements of 6.4, 6.5 and Clause 7 need not be applied to components inside the restricted breathing enclosure.

NOTE Luminaires, as normally employed, are considered to have an infrequent temperature cycle. Luminaires such as those using with strobe lights are considered to have a frequent temperature cycle.

20.2.1.2 Equipment not containing normally sparking devices

Restricted breathing equipment with no normally arcing or sparking devices, but containing hot surfaces in normal operation, shall be limited in dissipated power such that the temperature measured on the outside does not exceed the marked temperature class.

Switching devices not used in normal operation, such as an emergency stop switch, shall not be considered to be a normally arcing or sparking device.

The creepage and clearance distances for terminations on internal components shall be in compliance with Table 2.

20.2.2 Cable glands and conduit entries

20.2.2.1 Cable glands

Cable glands, whether integral or separate, shall meet the requirements of IEC 60079-0.

Where cable glands are integral with the enclosure or specific to the enclosure they shall be tested as part of the enclosure.

Where cable glands are separate:

- threaded Ex cable glands can be evaluated as 'nR' equipment;
- other cable glands can be evaluated only as an Ex 'nR' components.

NOTE The installation instructions provided with the equipment should contain information on the selection of cables.

20.2.2.2 Conduit entries

Conduit entries with tapered threads are considered to meet the requirements for "nR" equipment. Conduit entries with parallel threads shall only be used if the conduit sealing device is tested together with the enclosure. All conduit entries shall be sealed. All unused conduit entries shall be sealed with a blanking plug that meets the "nR" requirements.

NOTE 1 Conduit entry devices may be tested as required for normally non sparking equipment.

NOTE 2 The installation instructions provided with the equipment should contain information about the correct sealing of the conduit entry.

20.2.3 Operating rods, spindles and shafts

Openings in enclosures for rods, spindles or shafts shall have means to ensure the type of protection "nR", and shall not rely on grease or compound as a sole means to maintain sealing integrity, both when the spindles, rods or shafts are in motion and when they are at rest.

20.2.4 Windows

20.2.4.1 Cemented windows

A window design employing a cemented joint shall be such that it is cemented either directly into the wall of the enclosure so as to form with the latter an inseparable assembly, or into a frame such that the assembly can be replaced as a unit.

20.2.4.2 Gasketed windows

A window design employing a gasket to ensure type of protection "nR" shall be such that it is mounted directly in the wall or cover of the enclosure.

20.2.5 Gasket and seal requirements

Resilient gasket seals shall be positioned so that they are not subject to mechanical damage under normal operating conditions and they shall retain their sealing properties over the expected life of the equipment. Alternatively, the manufacturers shall specify a recommended replacement frequency and this shall be included in the instructions as specified in Clause 25.

20.2.6 Non-resilient seals

Non-resilient seals for restricted breathing equipment shall have a continuous operating temperature (COT) at least 10 K higher than the service temperature.

NOTE Non resilient seals do not require continuing internal stress to perform their function.

20.2.7 Test port

20.2.7.1 General

Equipment shall normally be provided with a test port to enable testing of the restricted breathing properties to be carried out after installation, during initial inspection and during maintenance.

NOTE The fitting of test points on restricted breathing equipment may not always be practical, for instance if the only part of the restricted breathing enclosure accessible from the outside of the overall enclosure is a glass globe.

Equipment where the nominal volume of the enclosure changes due to pressure during type testing shall always be equipped with a test port.

20.2.7.2 Test port exemptions

20.2.7.2.1 Luminaires

Gaskets and seals shall be fixed in position and shall be designed so that they can be readily replaced. Hard setting adhesives shall not be used.

NOTE If adhesives are used they should be pre-applied to the gasket material.

Luminaires may be exempted from the fitting of test port provided the following conditions are met:

- a) there are no normally arcing or sparking devices present in the restricted breathing enclosure, see also 20.2.1.2, and
- b) resilient gasket seals are mechanically protected so that they are not subject to mechanical damage during field installation or replacement, and
- c) the gaskets or seals exposed during re-lamping are of a type that can be readily replaced during the re-lamping process.

For equipment that does not have a test port fitted, the marking shall include the symbol "X", in accordance with of IEC 60079-0, and the specific conditions of use to be employed shall be specified in the documentation.

20.2.7.2.2 Other restricted breathing equipment

Where opening of the equipment is not foreseen when installed, it may also be exempted from the fitting of the test port. The warning label given in item f) of Table 14 shall be affixed to the equipment.

Equipment with no test port fitted shall include the symbol "X", in accordance with the marking requirements of IEC 60079-0, and instructions for conducting the restricted breathing test shall be given in the documentation along with any other specific conditions of use.

NOTE If such equipment must be opened for maintenance or any other reason, a routine test in accordance with 23.2.3 should be performed after re-closing.

20.2.7.2.3 Gasket and sealing replacement

The instructions shall contain information regarding the required replacement of the gasket or seal after any activity that requires the enclosure to be opened e.g. re-lamping of a luminaire.

NOTE To ensure that the "nR" properties will not be defeated by the opening and closing operation and based on the fact that without a test port a test of the restricted breathing properties in the field is not possible, it is recommended to replace the involved gaskets as part of this process.

20.2.7.2.4 Testing procedure

Restricted breathing equipment exempted from the fitting of a test point shall be type tested in accordance with 22.6.2.3 and in addition routine tested in accordance with 23.2.3.2.1.2.

20.2.8 Internal fans

If internal fans are fitted, the suction shall not induce a depression at a potential source of leakage.

20.2.9 Routine test exemptions

Equipment containing normally sparking devices shall always be routine tested.

NOTE 1 Statistical methods may be employed to verify production compliance.

Equipment not containing normally sparking devices but fitted with a test-port may be designed to be only type tested at a higher level as defined in 22.6.2.2.1 and in this case the routine test may be omitted.

NOTE 2 Information about the testing procedure after installation during initial inspection should be provided in the instruction manual and should comply with the requirements of IEC 60079-17.

20.3 Temperature limitation

20.3.1 General

If equipment is designed for different but fixed internal configurations, the worst case combination shall be used for determination the maximum surface temperature during the type test.

If equipment may be equipped with a variable combination of internal components, the surface temperature rise during type test may be measured with dummy loads. For this equipment, a routine test for determining the temperature class is required. The temperature rise of equipment under test may alternatively be calculated under the limitations given in 20.3.2.

20.3.2 Temperature calculation

The temperature rise of equipment as part of the routine test may be calculated adding the power dissipations of the single internal components. The sum of the calculated power dissipations shall be $\leq 80\%$ of the maximum power dissipation measured according to 20.3.1. The single power dissipation of the individual internal components shall be $\leq 10\%$ of the possible total power dissipation.

If the power-loss of an internal component is $> 10\%$ of the total possible power dissipation a temperature measurement shall be made as part of the routine test with the equipment under test fitted with all foreseen components and the temperature measurement procedure shall be in accordance with the requirements of IEC 60079-0.

20.4 Additional requirements for restricted breathing luminaires

20.4.1 Mounting arrangement

The mounting arrangement for restricted-breathing luminaires shall be so designed that the luminaire can pass the test for restricted-breathing whether or not it is mounted and any gaskets and/or special components necessary for this purpose shall be supplied with the luminaire.

20.4.2 Reflectors

Where provision has been made on the luminaire for the attachment of reflectors, the means of attachment shall not impair the restricted breathing properties of such luminaires.

20.4.3 Surface temperatures of restricted breathing luminaires

For restricted breathing luminaires under both normal and specified abnormal conditions only the temperature of any part of the external surface of a restricted-breathing luminaire shall not exceed that of the declared temperature class or the declared maximum surface temperature.

21 General information on verification and tests

The order of testing should be: any endurance test specified in this standard followed by impact testing, drop test for hand-held equipment and then IP tests and, where appropriate, the restricted-breathing test.

22 Type tests

22.1 Representative samples

Representative samples containing all windows, actuators gaskets and seals shall be tested in accordance with the requirements for type tests of this standard. The number of samples used shall be sufficient to perform the necessary tests specified in IEC 60079-0, plus any others required for testing specified in this standard.

22.2 Test configuration

Each test shall be made in that configuration of the equipment which is considered to be the most unfavourable by the person making the test.

22.3 Tests for enclosures on which the type of protection depends

22.3.1 Thermal endurance tests

22.3.1.1 Thermal endurance to heat

The thermal endurance to heat is determined by submitting the enclosure or parts of enclosures in non-metallic materials to continuous storage for $672 \frac{+30}{-0}$ h in an ambience of (90 ± 5) % relative humidity and at a temperature of (10 ± 2) K above the maximum temperature in rated service.

In the case of a maximum service temperature above $85 \text{ }^\circ\text{C}$, the period of $672 \frac{+30}{-0}$ h specified above will be replaced by a period of $336 \frac{+30}{-0}$ h at $(95 \pm 2) \text{ }^\circ\text{C}$ and (90 ± 5) % relative humidity followed by a period of two weeks at a temperature of (10 ± 2) K higher than the maximum temperature in rated service.

22.3.1.2 Drop test for hand-held equipment

For hand-held luminaires, the lamp filament need not remain intact after the drop test.

22.4 Tests for enclosed break devices and non incendive components

22.4.1 Preparation of enclosed-break device samples

Any elastomeric or thermoplastic material which is used for the purpose of sealing a cover which is intended to be opened in service, or which is unprotected against mechanical or environmental damage, shall be removed wholly or partially before the device or component is subjected to the type test when such removal will result in a more onerous test.

NOTE Any remaining non-metallic parts of the enclosure will have been subjected to the conditioning test described in 22.3.1.

22.4.2 Preparation of non-incendive component samples

For non-incendive components, the contacts shall be preconditioned by 6 000 cycles of operations at a rate of approximately six times per minute when carrying the rated electrical load.

The component shall be arranged to ensure that the test atmosphere has access to the contacts and that a resulting explosion will be detected. This may be achieved by

- a) removing the housing adjacent to the contacts, or
- b) drilling at least two holes in the enclosure, or
- c) drawing a vacuum, then filling the test chamber with the test mixture, using a pressure detection device to detect an ignition.

22.4.3 Test conditions for enclosed-break devices and non-incendive components

22.4.3.1 General

The device or component, which shall be arranged to have the most adverse dimensions permitted by the construction drawings, shall be filled with and surrounded by an explosive mixture according to the stated group of the equipment, as follows:

Group IIA: (6,5 ± 0,5) % ethylene/air at atmospheric pressure;

Group IIB: (27,5 ± 1,5) % hydrogen/air at atmospheric pressure;

Group IIC: (34 ± 2) % hydrogen, (17 ± 1) % oxygen and the remainder nitrogen at atmospheric pressure or alternatively (27,5 ± 1,5) % hydrogen/air at an overpressure of 500 mbar.

22.4.3.2 Enclosed-break devices

For enclosed-break devices, the explosive mixture within the device shall be ignited by the operation of the enclosed contacts when connected to the maximum rated source of energy and power, and maximum load, in terms of voltage, current, frequency and power factor. A make and break test shall be repeated 10 times with a fresh explosive mixture for each test and the explosive mixture surrounding the device shall not be ignited.

22.4.3.3 Non-incendive components

For non-incendive components, the contacts shall be operated 50 times at 100 % of the normal load when the component is filled with and surrounded by the explosive mixture. This make and break test shall be repeated three times with a fresh gas mixture for each test and the explosive mixture surrounding the device shall not be ignited.

NOTE "Specified electrical load" means the current and voltage under normal operating conditions of the circuit in which the component is used or for which safety has been verified.

22.5 Tests for sealed devices

22.5.1 Conditioning

Three samples of the device shall be conditioned, in an air oven for 168 ± 30 h at a temperature at least 10 K higher than, than the maximum service temperature but not less than 80 °C. This conditioning is followed by at least 24 h at least 10 K lower than the minimum service temperature.

NOTE The conditioning in accordance with IEC 60079-0 may be substituted.

22.5.2 Voltage test

The terminals of the device are connected together and a sinusoidal voltage applied for 1 min between the terminals and the outer surface of the device. The r.m.s. value is not less than V_{pk} or $(2U + 1\,000)$ V whichever is the greater, where V_{pk} is the maximum peak output voltage of the device and U is the working voltage. Where the working voltage is 42 V or less, the test voltage is 500 V instead of $(2U + 1\,000)$ V. Metal foil is placed around the outer surface of the case if the latter is made of plastic material.

Compliance shall be checked as follows: the voltage test shall not produce electrical breakdown or dangerous discharge; the sample shall be subjected to visual examination. No damage that could impair the type of protection shall be evident.

22.5.3 Tests on devices with free space

22.5.3.1 Equipment for leakage test on sealed devices

A container of transparent material and of sufficient volume to enable the complete immersion of the test sample. The container shall have the following additional features according to whether method 1 or method 2 is used.

a) Method 1

The container shall enable the heating of the test fluid to the temperature required by item a) of 22.5.3.2 with provision for stirring to maintain a uniform bath temperature over a long period and for the insertion of a suitable temperature measuring device.

b) Method 2

The container shall enable the connection to a vacuum pump capable of reducing the pressure over the surface of the liquid and maintaining it at the required value for a minimum duration of 2 min.

The test fluid shall either be tap water or de-ionized water.

22.5.3.2 Leakage test on sealed devices

The leakage test on sealed devices shall be performed using one of the following methods:

a) Method 1

With the test samples at an initial temperature of (25 ± 2) °C, they are suddenly immersed in water at a temperature of (65 ± 2) °C to a depth of 25 mm for 1 min. If no bubbles emerge from the samples during this test, they are considered to be "sealed" for the purposes of this standard.

b) Method 2

The test samples are immersed to a depth of 75 mm in water contained in an enclosure that can be partially evacuated. The air pressure within the enclosure is reduced by the equivalent of 120 mm Hg (16 kPa). There shall be no evidence of leakage from the interior of the device.

c) Method 3

As an alternative to a) or b), any other method that shows that the devices leak at a rate not greater than 10^{-5} ml of air per second at a pressure differential of 1 atmosphere (101,325 Pa).

22.5.3.3 Dielectric withstand test

The test in 22.5.2 shall be repeated after the leakage test.

22.5.4 Test for sealed devices for luminaires

If the device contains a poured seal or encapsulating compound in thermosetting material, the device shall be placed in a temperature cabinet and cooled to $-10\text{ }^{\circ}\text{C}$ or lower for 1 h. The device is then heated to a temperature of at least 10 K above the maximum case temperature of the device for 1 h.

If the device contains a gasket or seal of thermoplastic or elastomeric material it is heated in an air oven for 7 days at a temperature of at least 10 K above that occurring when the device is operating under maximum rated service conditions as determined by the testing laboratory or declared by the manufacturer.

The test samples shall then be subjected to one of the following leakage tests:

- a) with the test samples at an initial temperature of $(25 \pm 2)\text{ }^{\circ}\text{C}$, they are suddenly immersed in water at a temperature of $(50 \pm 2)\text{ }^{\circ}\text{C}$ to a depth of 25 mm for 1 min. If no bubbles emerge from the samples during this test, they are considered to be "sealed" for the purposes of this standard;
- b) the test samples are immersed to a depth of 75 mm in water contained in an enclosure that can be partially evacuated. The air pressure within the enclosure is reduced by the equivalent of 120 mm Hg (16 kPa). There shall be no evidence of leakage from the interior of the device;
- c) any other test that shows that the devices leak at a rate not greater than 10^{-5} ml of air per second at a pressure differential of 1 atmosphere (101,325 kPa).

22.6 Type test requirements for restricted-breathing enclosures**22.6.1 General**

Type nR restricted breathing equipment shall be subjected to all applicable tests of IEC 60079-0 prior to the specific required type tests for restricted breathing.

If the design of the enclosure is such that the rate of breathing is independent of the direction of the pressure, or the application of a positive pressure results in a more onerous condition, the test may alternatively be performed with a positive pressure within the enclosure.

22.6.2 Test procedures

22.6.2.1 Equipment where the nominal volume of the enclosure will be unchanged due to pressure

22.6.2.2 Equipment with test port

22.6.2.2.1 Type test only without additional routine test

Under constant temperature conditions, the time interval for an internal pressure of at least 0,3 kPa (30 mm water gauge) below atmospheric to change to half the initial value shall be not less than 360 s.

22.6.2.2.2 Type test with additional routine test

Under constant temperature conditions, the time interval for an internal pressure of at least 0,3 kPa (30 mm water gauge) below atmospheric to change to half the initial value shall be not less than 90 s.

22.6.2.3 Type test for equipment without test port

Under constant temperature conditions, the time interval for an internal pressure of at least 0,3 kPa (30 mm water gauge) below atmospheric to change to half the initial value shall be not less than 180 s.

22.6.3 Alternative type test for equipment where the nominal volume of the enclosure changes due to pressure

As an alternative to the tests in 22.6.2.2 and 22.6.2.3 the enclosure may be pressurized with air maintained at an overpressure of 0,4 kPa. The rate of supply of air in litres per hour (l/h) required to maintain this overpressure shall be measured. The value divided by the net enclosure volume in litres (l) shall not exceed 0,125.

22.7 Test for screw lampholders

NOTE 1 These insertion and withdrawal tests do not have to be carried out with E10 lampholders.

For E14, E27 and E40 lampholders, a test cap with dimensions complying with IEC 60238 shall be fully inserted into a sample lampholder applying a torque according to the type of lampholder, as given in Table 11.

For E13, E26 and E39 lampholders, an equivalent test shall be performed based on the dimensional requirements of IEC 60238, modified for differences between related lamp caps given in IEC 60061 (all parts).

NOTE 2 If certification (third party) is sought, it is not a requirement of this standard that the certification body confirm conformance to IEC 60238. The basis of compliance should be stated in the manufacturer's documentation, see Clause 25.

Table 11 – Insertion torque

Lamp cap	Torque Nm
E14/E13	1,0 ± 0,1
E27/E26	1,5 ± 0,1
E40/E39	2,25 ± 0,1

The test cap shall then be partly withdrawn by rotating through 15°.

The minimum torque then required to remove the cap shall be not less than that given in Table 12.

Table 12 – Minimum removal torque

Lamp cap	Torque Nm
E14/E13	0,3
E27/E26	0,5
E40/E39	0,75
NOTE Where vibration is severe, special mounting should be provided for the luminaires.	

22.8 Test for starter holders of luminaires

Three samples of the starter holder are placed in a heating cabinet in which the ambient temperature is maintained at $(85 \pm 2) ^\circ\text{C}$.

After a total of 72 h, the starter holders are removed from the heating cabinet and allowed to cool for 24 h. The contact pressure is then measured by means of a device made according to the dimension of the gauge detailed in IEC 60400.

The contact force shall be not less than 5 N.

NOTE If certification (third party) is sought, it is not a requirement of this standard that the certification body confirm conformance to IEC 60400. The basis of compliance should be stated in the manufacturer's documentation, see Clause 25

22.9 Tests for electronic starters for tubular fluorescent lamps and for ignitors for high pressure sodium or metal halide lamps

22.9.1 General

Ignitors are categorized according to the following features:

- the peak pulse voltage (V_{pk}) generated at the lamp does not exceed 1,5 kV, 2,8 kV or 5,0 kV;
- the ignitor may or may not be fitted with a cut-out device to inhibit repeated starting attempts should the associated lamp either fail to start or fail during operation;
- the ignitor may or may not cause the peak pulse voltage to be applied to the luminaire ballast winding.

22.9.2 Moisture resistance, insulation and electric strength test

Electronic starters and ignitors shall comply with IEC 61347-1 with respect to moisture resistance, insulation and electric strength. The duration of humidity conditioning shall be 168 h.

NOTE If certification (third party) is sought, it is not a requirement of this standard that the certification body confirm conformance to IEC 61347-1. The manufacturer should state the basis of compliance in the documentation, see Clause 25.

22.9.3 Cut-out device test

Where an electronic starter or ignitor is fitted with a cut-out device, three individual units shall be tested at air temperatures of $(-25 \pm 2) ^\circ\text{C}$, $(25 \pm 2) ^\circ\text{C}$ and a temperature that is at least the maximum case temperature +10 K (unless operating temperature limits are explicitly stated otherwise) Compliance shall be checked as follows:

- a) on starters for tubular fluorescent lamps, the starter is energized on ten successive occasions with at least 15 s between starting attempts. The cut-out device shall operate on lamp failure (failed discharge but intact cathodes, simulated by removing lamp from circuit and replacing with dummy cathode resistors) within 10 s to prevent further lamp starting attempts;
- b) on ignitors for high pressure sodium lamps and metal/mercury halide lamps, the ignitor is operated on ten successive occasions until the cut out operates on each occasion. The cut-out device shall operate on lamp failure (failed discharge or no ignition in cold conditions simulated by removing lamp from circuit) within 125% of the rated time shown on the ignitor.

If all three individual units comply with the requirements, the ignitor shall be classified as "with cut-out device". If any of the three individual units fail to comply, the ignitor shall be classified as "without cut-out device" and subsequent tests shall be carried out on samples with the cut-out device isolated or removed so as to render the device inoperative and the ignitor deemed unsuitable for use where the ignitor stresses the ballast winding.

22.9.4 Life test (failed lamp)

22.9.4.1 Ignitor thermal endurance test

A further three individual ignitors shall pass the following thermal endurance test.

- a) Ignitors without a cut-out device
 - 1) Energize at the maximum rated operating voltage, at highest operating frequency (or lowest if this produces the highest temperature rise within the ignitor) in a circuit simulating the failed lamp condition.
 - 2) Raise the ambient temperature in a draught-free oven or enclosure to 60 °C.
 - 3) Leave the ignitor in a stable state for 60 days.
 - 4) De-energize, remove the ignitor from the oven or enclosure and cool to room temperature.
- b) Ignitors with a cut-out device
 - 1) Raise the ambient temperature in a draught-free oven or enclosure to 60 °C.
 - 2) Energize at the maximum stated operating voltage, at the highest operating frequency (or lowest if this produces highest temperature rise within ignitor), in a circuit simulating the failed lamp condition for a nominal 30 min on 30 min off cycle.
 - 3) Continue the test until 500 cycles are complete.
 - 4) De-energize, remove the ignitor from the oven or enclosure and cool to room temperature.

22.9.4.2 Evaluation criteria

The electronic starter/ignitor shall be re-examined and shall either:

- a) operate within the stated electrical operating characteristics and temperature classification (if assigned) and shall exhibit no mechanical or structural defect so as to render the unit unsafe or likely to generate an ignition hazard, or
- b) have failed to a "safe" condition without passing through an incendive or sparking mode and without exhibiting any mechanical or structural defect.

22.10 Test for wiring of luminaires subject to high-voltage impulses from ignitors

The test voltage at a nominal frequency of 50 Hz or 60 Hz is applied for 1 min between the conductor and a metal foil of width 25 mm wrapped around the external surfaces of the test sample insulation but not nearer than 25 mm to the bare conductors. The test sample is at least 500 mm long.

The voltage is 3 kV r.m.s. in circuits using ignitors marked with 2,8 kV, or 5 kV r.m.s. in circuits using ignitors marked 5,0 kV.

No flashover or breakdown shall occur during the test.

22.11 Mechanical shock test for batteries

22.11.1 General

The test shall be carried out on a sample, comprising at least four new and fully charged cells in a 2 × 2 formation complete with internal connectors. The sample shall be in ready-for-use condition.

The sample shall be mounted in its normal operating attitude and by its normal means of attachment, either directly or by means of a rigid fixture, to the mounting surface of the shock machine. The mounting shall satisfy the requirements of 4.3 of IEC 60068-2-27.

The shock machine shall generate a half-sine pulse as shown in Figure 2 of IEC 60068-2-27. The velocity change tolerance, transverse motion and measuring system shall satisfy the requirements of 4.1.2, 4.1.3 and 4.2 respectively of IEC 60068-2-27. The peak acceleration value shall be 5 g_n as defined in Table 1 of IEC 60068-2-27.

22.11.2 Test procedure

The test procedure shall be as follows:

- a) the capacity of the sample is determined;
- b) a constant 5 h discharge current flows during the test;
- c) 15 independent shocks are applied to the sample as follows:
 - 1) three successive shocks in the vertically upwards direction,
 - 2) three successive shocks in each direction along two perpendicular axes in the horizontal plane. These axes are chosen so as to reveal possible weaknesses;
- d) after recharging, the capacity is again determined.

22.11.3 Evaluation criteria

The three following conditions shall be satisfied:

- a) no abrupt change in voltage during the test;
- b) no visible damage or deformation;
- c) no reduction in capacity of more than 5 %.

22.12 Insulation resistance test for batteries

22.12.1 Test conditions

The test conditions are as follows:

- a) the measuring voltage of the ohmmeter shall be at least 100 V;
- b) all connections between the battery and the external circuits and, where fitted, the battery container shall be disconnected;
- c) the cells shall be filled with electrolyte up to the maximum permissible level.

22.12.2 Evaluation criteria

The insulation resistance is considered satisfactory if the measured value is at least equal to the value specified in 12.5.2.11.

22.13 Additional ignition tests for large or high-voltage machines

22.13.1 Test for cage rotor construction

22.13.1.1 General

The test shall be carried out using a machine having a stator and rotor that are representative of a finished machine in terms of the stator core and windings, and the rotor core and cage. This shall include ducts, centering rings, rings under the end rings and balance discs, where appropriate.

22.13.1.2 Rotor cage ageing process

The rotor cage shall be subject to an ageing process comprising a minimum of five locked rotor tests. The maximum temperature of the cage shall cycle between the maximum design temperature and less than 70 °C. The applied voltage shall be not less than 50 % of the rated voltage.

22.13.1.3 Ignition test

After the ageing process of 22.13.1.2 the machine shall be filled with, or immersed in, an explosive gas mixture as shown in Table 13. Motors shall be subjected to 10 direct-on-line uncoupled starts or 10 locked rotor tests. These tests shall have a duration of at least 1 s.

No ignition of the explosive test mixture shall occur.

During the tests, the terminal voltage shall not fall below 90 % of the rated voltage. The concentration of the explosive test mixture shall be confirmed after each test.

22.13.2 Test for stator winding insulation system incendivity

22.13.2.1 General

The tests shall be carried out on any of the following:

- one complete stator;
- one stator with motor enclosure;
- one motor;
- a partially wound stator;
- a group of coils.

In all cases, the test model shall be representative of a complete stator with, where appropriate, corona shield, stress grading, packing and bracing, impregnation and conductive parts such as the stator core. All exposed conductive parts shall be earthed.

22.13.2.2 Test conditions

Typical stator connection cables arrangements shall be tested either on one complete stator or in a representative model. Particular care shall be taken with the spacing of the cables, both from each other and from adjacent conductive parts. All such exposed conductive parts shall be earthed.

22.13.2.3 Steady state ignition test

Insulation systems and connection cables shall be tested in an explosive test mixture as shown in Table 13 with a sinusoidal voltage of at least 1,5 times the rated r.m.s. line voltage for at least 3 min. The maximum rate of voltage rise shall be 0,5 kV/s. The voltage shall be applied between one phase and earth with the other phases earthed.

No ignition of the explosive test mixture shall occur.

Table 13 – Explosion test mixtures

Equipment group	Test mixture in air v/v
IIC	(21 ± 5) % hydrogen
IIB	(7,8 ± 1) % ethylene
IIA	(5,25 ± 0,5) % propane

NOTE The values shown in this table represent a mixture that represents the minimum ignition energy for the equipment group.

23 Routine verifications and tests

23.1 General

The manufacturer shall carry out any routine verifications and tests necessary to ensure that the electrical equipment produced complies with the equipment specification in accordance with the requirements of IEC 60079-0. The manufacturer shall also carry out any relevant routine tests given in 23.2.

23.2 Specific routine tests

23.2.1 Electric strength test

A dielectric strength test shall be carried out in accordance with 6.5.1. Alternatively, the test shall be carried out at 1,2 times the test voltage, but shall be maintained for at least 100 ms.

NOTE In some cases, the actual test period could be significantly longer than 100 ms as a sample with a large distributed capacitance may take some additional time to reach the actual test voltage.

23.2.2 Alternate dielectric strength test

For equipment subject to the exception of 6.4.1, the test of 6.5.2 shall be performed as a routine test. Alternatively, a test shall be carried out at 1,2 times the test voltage, but shall be maintained for at least 100 ms.

23.2.3 Routine test requirements for restricted-breathing enclosures

23.2.3.1 General

If the equipment is equipped with a test port, the test port may be used for the routine test. Cable glands may be replaced by blanking plugs for the routine test. If the equipment is not equipped with a test port, the equipment may be tested using the cable glands or conduit entry devices.

NOTE 1 The use of the cable gland including the sealing system demonstrates that the restricted breathing properties are not negatively influenced by the cable gland entry device.

NOTE 2 Where routine testing is not carried out, the manufacturer will need to use quality control measures to ensure that the equipment meets or exceeds the test values when installed.

NOTE 3 Where there is no cable entry to the restricted breathing enclosure or test point, dummy assemblies representing the sealing surface gasket compression and volume may be substituted as long as the gasket remains with the equipment being tested.

23.2.3.2 Test procedure

23.2.3.2.1 Equipment where the nominal volume of the enclosure will be unchanged due to pressure

23.2.3.2.1.1 Equipment with test port

Under constant temperature conditions, the time interval required for an internal pressure of at least 0,3 kPa (30 mm water gauge) below atmospheric to change to half the initial value shall be not less than 90 s.

Alternatively following test procedures may be used:

- Under constant temperature conditions, the time interval required for an internal pressure of 3,0 kPa (300 mm water gauge) below atmospheric to change to 2,7 kPa (270 mm water gauge) below atmospheric shall be not less than 14 s.
- Under constant temperature conditions, the time interval required for an internal pressure of 0,3 kPa (30 mm water gauge) below atmospheric to change to 0,27 kPa (27 mm water gauge) below atmospheric shall be not less than 14 s.

NOTE The alternatives are added to shorten the time needed for the routine tests using adjusted figures for the possible pressure reduction. If using the low value of pressure creates difficulties the alternative 10 times higher figures may be used.

23.2.3.2.1.2 Equipment without test port

Under constant temperature conditions, the time interval required for an internal pressure of at least 0,3 Pa (30 mm water gauge) below atmospheric to change to half the initial value shall be not less than 180 s.

Alternatively following test procedures may be used.

- Under constant temperature conditions, the time interval required for an internal pressure of 3,0 kPa (300 mm water gauge) below atmospheric to change to 2,7 kPa (270 mm water gauge) below atmospheric shall be not less than 27 s.
- Under constant temperature conditions, the time interval required for an internal pressure of 0,3 kPa (30 mm water gauge) below atmospheric to change to 0,27 kPa (27 mm water gauge) below atmospheric shall be not less than 27 s.

NOTE The alternatives are added to shorten the time needed for the routine tests using adjusted figures for the possible pressure reduction. If using the low value of pressure creates difficulties, the alternative 10 times higher figures may be used.

23.2.3.2.2 Equipment where the nominal volume of the enclosure changes due to pressure

The enclosure shall be pressurized with air maintained at an overpressure of 0.4 kPa. The rate of supply of air in litres per hour (l/h) necessary to maintain this overpressure shall be measured. The value divided by the net enclosure volume in litres (l) shall not exceed 0,125.

23.2.4 Routine tests for electronic starters and ignitors

For electronic starters for tubular fluorescent lamps and for ignitors for high pressure sodium or metal halide lamps, a routine test is carried out in accordance with the voltage type test of 22.9.3 but for a period of at least 3 s.

24 Marking

24.1 General

Marking shall include the required elements of IEC 60079-0, and also any other marking required by this standard and other relevant standards with which the equipment complies. The marking shall also include any marking normally required by the standards for construction of the electrical equipment.

Where it is necessary to include marking from one of the other methods of protection listed in IEC 60079-0, the marking required by this standard shall occur first. Where multiple methods of protection are used within a piece of type n equipment, they shall all be identified in the marking in alphabetical order.

NOTE This is to avoid possible confusion over the suitability of the equipment for a specific location.

For non-incendive components and equipment and components, marking shall include all the electrical parameters concerning explosion safety (for example: voltage, current, inductance and capacitance) as applicable.

Where IP marking is required equipment shall be marked in accordance with 6.3.

24.2 Additional marking for batteries

For batteries, the following marking shall be indicated:

- the type of construction of cells;
- number of cells and nominal voltage;
- rated capacity with the corresponding duration of discharge.

Battery manufacturer and part number may be used as an alternative to marking for the batteries.

If no safety measures are applied, then the battery container or battery pack shall carry the warning given in item d) of Table 14.

If it is possible to insert both primary and secondary cells in the equipment or battery container when these are only designed for secondary cells, shall carry the warning given in item e) of Table 14.

NOTE Instructions for use (instructions for maintenance), for display in the battery charging station, should be supplied with each battery. These should include all instructions necessary for charging, use and maintenance.

The instructions for use should include at least the following information:

- the name of the manufacturer or supplier or the registered trade mark,
- the manufacturer's type identification,
- the number of cells and the nominal voltage of the battery,
- the rated capacity with the corresponding duration of discharge,
- the charging instructions,
- any other conditions concerning the safe operation of the battery, for example the lifting of the cover during charging, the minimum time before closing the cover because of the release of gas after termination of charging, the checking of the electrolyte level, the specifications for the electrolyte water for topping up.

24.3 Examples of marking

NOTE These examples do not include the marking normally required by the standards for construction of the equipment.

- Example 1: Non-sparking equipment incorporating a flameproof lighting fitting for ambient temperature range -20 °C to $+60\text{ °C}$, with specific conditions of use and without third-party certification.

Engler Industries Ltd

Type HXR

Ex nA d IIB T3 Gc

$-20\text{ °C} \leq T_a \leq +60\text{ °C}$

Certificate number: 045673X

- Example 2: Equipment with restricted-breathing enclosure as a component without third-party certification.

XYZ Ltd

Type 1456

Ex nR IIC Gc

Certificate number: 986U

- Example 3: Non sparking equipment incorporating a sealed relay.

XYZ Ltd

Model Trd

Ex nA nC IIC T4 Gc

Certificate number: 08564

- Example 4: Equipment with restricted-breathing enclosure with a encapsulated ballast.

XYZ Ltd

Type 1456

Ex nC nR IIC T3 Gc

Certificate number: 06T56

24.3.1 Warning markings

Where any of the following markings are required on the equipment, the text as described in Table 14, following the word "WARNING", may be replaced by technically equivalent text. Multiple warnings may be combined into one equivalent warning.

Table 14 – Text of warning markings

	Reference	Warning marking
a)	9.4	WARNING – DO NOT REMOVE OR REPLACE FUSE WHEN ENERGIZED
b)*	7.3.5, 10.1 b)	WARNING – DO NOT SEPARATE WHEN ENERGIZED
c)*	12.5.2.8	WARNING – SEPARATE ONLY IN A NON-HAZARDOUS AREA
d)	24.2	WARNING – DO NOT CHARGE IN A HAZARDOUS AREA
e)	24.2	WARNING – DO NOT USE PRIMARY CELLS
f)	20.2.7.2.2	WARNING – DO NOT OPEN, MAINTAIN OR SERVICE IN AN AREA WHERE AN EXPLOSIVE ATMOSPHERE MAY BE PRESENT

	Reference	Warning marking
*		Identical to the warning markings in IEC 60079-0.

25 Documentation

Documentation in addition to that which is required in the documentation and instructions of IEC 60079-0 shall be provided when specified in this standard. Additional documentation required includes:

- information on reduced ingress protection for components (see 6.3);
- the degree of protection when it is provided by the installation (see 6.3.2);
- the basis of compliance of rotating machines to IEC 60034 including the duty (see 8.1);
- for motors with duty of S₁ to S₁₀, information where special measures are to be employed to ensure that the enclosure of a large rotating machine rated over 100 kW does not contain an explosive gas atmosphere at the time of starting (see 8.8.3);
- radial air gap (see 8.7)
- information concerning the basis of compliance of luminaires to the relevant subclauses of IEC 60598-2 (see 11.1);
- information where external transient limiting means are to be provided for non-sparking low power equipment (see Clause 13);
- information on the replacement frequency for gaskets of restrictive-breathing enclosures (see 20.2.5).
- information on COT of materials where necessary.
- information concerning the necessity of replacing gaskets in luminaires during re-lamping

26 Instructions

Instructions shall be provided in accordance with the requirements of IEC 60079-0.

Annex A (informative)

Application, installation, and testing considerations for Ex “nA” asynchronous machines

A.1 Surface temperature

Research and testing have demonstrated that electrical machines of normal industrial designs operating at rated full-load steady-state conditions will not have excessive surface temperatures, and there is minimal risk of ignition of a flammable gas-air mixture release that has a mixture auto-ignition temperature of greater than 200 °C. Surface temperatures of electrical machines operating at rated load, seldom exceed 155 °C for the stator (i.e., Class F insulation hot spot temperature) and 200 °C (for large machines and high-efficiency small machines) to 300 °C (for lower-efficiency small machines) for the rotor. Air turbulence around the rotor components, while in operation, and rapid decay of rotor temperature as a rotor comes to a halt, greatly reduces the risk of ignition of all but materials with low auto-ignition temperatures. There has not been a demonstrated need to take special precautions for normal industrial designs of electrical machines due to surface temperature considerations for application in environments where the flammable gas environment requires equipment of temperature classes T1, T2, or T3 (i.e., temperature of 200 °C or greater).

Anti-condensation space heaters, mounted within the frames of electrical machines, can generally be designed to remain within the temperature classification of the machine; so additional high temperature assessment is generally not necessary.

Maximum surface temperature determination in accordance with IEC 60079-0 may not always require testing of every sample. Often, the test data resulting from the testing of prototypes can be extrapolated to cover additional motors in a series. In these cases, the test report should always clearly identify the tests that were omitted and the justification for omitting them.

Surface temperature measurements for the stator and rotor of motors may not be required for motors with assigned temperature classes T1, T2, or T3 with Thermal Class 105 (A) or 130 (B) in accordance with IEC 60085. Rotor surface temperature can be determined by calculation based upon manufacturer's experience or by prototype testing of representative samples with appropriate adjustment factors.

For rotor temperature determination of motors with assigned temperature classes T4, T5, or T6, non-destructive test methods can be used. These methods may include the use of the rotor-slip method, application of temperature-sensitive paints or stickers, or telemetry of measurements from temperature sensors that are temporarily mounted on the rotor. Rotor surface temperatures for similar designs can then be determined by calculation based upon manufacturer's experience or by prototype testing of representative samples with appropriate adjustment factors. Stator and bearing temperature determinations require separate consideration.

The service temperature determination of other components as defined in IEC 60079-0 may be required for items such as gaskets, cable glands (if included with the motor), etc.

A.2 Starting

Starting (acceleration) of an electrical machine is excluded as part of normal operation for an Ex “nA” machine under duty S1 or S2, with no restrictions on the frequency of starting other than the requirement that the motor temperatures reach thermal equilibrium (cool) before re-

starting. "Normal" operating conditions for electric machines are assumed to be rated full-load steady conditions. Small motors with cast rotor cages present almost no risk of being an ignition source during the motor starting period. Large, high-speed motors of fabricated rotor cage construction present a higher risk of sparking within the air gap of the machine during a very brief period of the total starting sequence.

For Ex "nA" machines of duty S3 to S10, the user of an Ex "nA" machine should consider both the frequency of machine starting for the application and the potential consequence of an ignition event. Special measures such as pre-start ventilation or soft-starting; or even a machine employing a different type of protection, could be used to further reduce the risk of ignition.

A.3 Rated voltage and surface discharges

At the higher ratings of stator operating voltages, incendive surface discharges can occur, particularly if the stator and winding surfaces are dirty. Since the corona discharge could potentially be a continuous ignition source, this effect must be considered during normal machine operation.

Industry experience is that properly maintained electrical machines with rated voltages up to and including 4 160 V phase-to-phase do not present an unacceptable risk of ignition due to winding surface discharges. For higher voltages, an electrical machine complying with the requirements for Ex "nA" or those of another type of protection should be considered.

Bibliography

- IEC 60034-5, *Rotating electrical machines – Part 5: Degrees of protection provided by the integral design of rotating electrical machines (IP Code) – Classification*
- IEC/TS 60034-17, *Rotating electrical machines – Part 17: Cage induction motors when fed from converters – Application guide*
- IEC/TS 60034-18-41, *Rotating electrical machines – Part 18-41: Qualification and type tests for Type I electrical insulation systems used in rotating electrical machines fed from voltage converters*
- IEC 60050-411:1996, *International Electrotechnical Vocabulary – Part 411: Rotating machines*
- IEC 60050-426, *International Electrotechnical Vocabulary – Part 426: Equipment for explosive atmospheres*
- IEC 60068-2-6, *Environmental testing – Part 2-6: Tests – Test Fc: Vibration (sinusoidal)*
- IEC 60079-4, *Electrical apparatus for explosive gas atmospheres – Part 4: Method of test for ignition temperature*
- IEC 60079-7: 2006, *Explosive atmospheres – Part 7: Equipment protection by increased safety "e"*
- IEC 60079-17, *Explosive atmospheres – Part 17: Electrical installations inspection and maintenance*
- IEC 60079-18, *Explosive atmospheres – Part 18: Equipment protection by encapsulation "m"*
- IEC 60079-29-2, *Explosive atmospheres – Part 29-2: Gas detectors – Selection, installation, use and maintenance of detectors for flammable gases and oxygen*
- IEC 60085, *Electrical insulation – Thermal evaluation and designation*
- IEC 60297 (all parts), *Mechanical structures for electronic equipment – Dimensions of mechanical structures of the 482,6 mm (19 in) series*
- IEEE Paper No. PCIC-2005-31, D. E. Delaney and M. K. Bruin, "Surface Temperature Test Methods Per IEEE 1349," IEEE Transactions on Industry Applications, vol 43, no. 3, May/June 2007, pp. 821 – 828.
- IEEE Paper No. PCIC-98-03, P. S. Hamer, B. M. Wood, R. L. Doughty, R. L. Gravell, R. C. Hasty, S. E. Wallace, and J. O. Tsao, "Flammable Vapor Ignition by Hot Rotor Surfaces Within an Induction Motor -- Reality or Not?," IEEE Transactions on Industry Applications, vol 35, no. 1, Jan/Feb 1999, pp. 100 – 113.
- API RP2216:2003, *Ignition risk of hydrocarbon liquids and vapors by hot surfaces in the open air*

<http://www.china-gauges.com/>

British Standards Institution (BSI)

BSI is the national body responsible for preparing British Standards and other standards-related publications, information and services.

BSI is incorporated by Royal Charter. British Standards and other standardization products are published by BSI Standards Limited.

About us

We bring together business, industry, government, consumers, innovators and others to shape their combined experience and expertise into standards-based solutions.

The knowledge embodied in our standards has been carefully assembled in a dependable format and refined through our open consultation process. Organizations of all sizes and across all sectors choose standards to help them achieve their goals.

Information on standards

We can provide you with the knowledge that your organization needs to succeed. Find out more about British Standards by visiting our website at bsigroup.com/standards or contacting our Customer Services team or Knowledge Centre.

Buying standards

You can buy and download PDF versions of BSI publications, including British and adopted European and international standards, through our website at bsigroup.com/shop, where hard copies can also be purchased.

If you need international and foreign standards from other Standards Development Organizations, hard copies can be ordered from our Customer Services team.

Subscriptions

Our range of subscription services are designed to make using standards easier for you. For further information on our subscription products go to bsigroup.com/subscriptions.

With **British Standards Online (BSOL)** you'll have instant access to over 55,000 British and adopted European and international standards from your desktop. It's available 24/7 and is refreshed daily so you'll always be up to date.

You can keep in touch with standards developments and receive substantial discounts on the purchase price of standards, both in single copy and subscription format, by becoming a **BSI Subscribing Member**.

PLUS is an updating service exclusive to BSI Subscribing Members. You will automatically receive the latest hard copy of your standards when they're revised or replaced.

To find out more about becoming a BSI Subscribing Member and the benefits of membership, please visit bsigroup.com/shop.

With a **Multi-User Network Licence (MUNL)** you are able to host standards publications on your intranet. Licences can cover as few or as many users as you wish. With updates supplied as soon as they're available, you can be sure your documentation is current. For further information, email bsmusales@bsigroup.com.

BSI Group Headquarters

389 Chiswick High Road London W4 4AL UK

Revisions

Our British Standards and other publications are updated by amendment or revision.

We continually improve the quality of our products and services to benefit your business. If you find an inaccuracy or ambiguity within a British Standard or other BSI publication please inform the Knowledge Centre.

Copyright

All the data, software and documentation set out in all British Standards and other BSI publications are the property of and copyrighted by BSI, or some person or entity that owns copyright in the information used (such as the international standardization bodies) and has formally licensed such information to BSI for commercial publication and use. Except as permitted under the Copyright, Designs and Patents Act 1988 no extract may be reproduced, stored in a retrieval system or transmitted in any form or by any means – electronic, photocopying, recording or otherwise – without prior written permission from BSI. Details and advice can be obtained from the Copyright & Licensing Department.

Useful Contacts:

Customer Services

Tel: +44 845 086 9001

Email (orders): orders@bsigroup.com

Email (enquiries): cservices@bsigroup.com

Subscriptions

Tel: +44 845 086 9001

Email: subscriptions@bsigroup.com

Knowledge Centre

Tel: +44 20 8996 7004

Email: knowledgecentre@bsigroup.com

Copyright & Licensing

Tel: +44 20 8996 7070

Email: copyright@bsigroup.com