

BS EN 60079-18:2015



BSI Standards Publication

Explosive atmospheres

Part 18: Equipment protection by
encapsulation "m"

bsi.

...making excellence a habit.™

National foreword

This British Standard is the UK implementation of EN 60079-18:2015. It is identical to IEC 60079-18:2014. It supersedes BS EN 60079-18:2009 which is withdrawn.

BSI, as a member of CENELEC, is obliged to publish EN 60079-18 as a British Standard. However, attention is drawn to the fact that the UK committee voted against its approval as a European Standard.

This was due to an internal inconsistency in clause 7.2.

Clause 7.2.1 states that faults are not taken into account for "mc", whereas the last sentence of 7.2.4.2 specifies absolute requirements for "mc" to avoid faults, making the requirements for some "mc" circuits more arduous than the same circuit for "ma" or "mb".

As this is not new text for this edition it is assumed that in many cases this has been resolved by the manufacturer and certified to 7.2.1 and then assuming, for "mc" equipment, that there is no need to read further into 7.2, therefore ignoring 7.2.4.2.

As it is not possible to satisfy both 7.2.1 and 7.2.4.2 at the same time, it is the opinion of the UK committee that 7.2.4.2 is not intended to be observed for "mc" equipment, and they have requested that IEC issue a formal corrigendum to that effect.

It is believed that the "mc" column of Table 1 was erroneously copied from 60079-15 and the purpose changed. In 60079-15, the table referred to segregation under 0.4 mm of compound in an IP54 enclosure for Ex nA equipment. That is to say that a 0.4 mm layer of encapsulant was considered to be better than conformal coating in terms of environmental protection. It was not related to the ability of the encapsulation to withstand an internal fault. The table was not applied to Ex n encapsulation and therefore should not have been applied to Ex mc.

The UK participation in its preparation was entrusted to Technical Committee EXL/31, Equipment for explosive atmospheres.

A list of organizations represented on this committee can be obtained on request to its secretary.

This publication does not purport to include all the necessary provisions of a contract. Users are responsible for its correct application.

© The British Standards Institution 2015.
Published by BSI Standards Limited 2015

ISBN 978 0 580 80686 5

ICS 29.260.20

Compliance with a British Standard cannot confer immunity from legal obligations.

This British Standard was published under the authority of the Standards Policy and Strategy Committee on 30 June 2015.

Amendments/corrigenda issued since publication

Date	Text affected
------	---------------

EUROPEAN STANDARD

EN 60079-18

NORME EUROPÉENNE

EUROPÄISCHE NORM

April 2015

ICS 29.260.20

Supersedes EN 60079-18:2009

English Version

Explosive atmospheres - Part 18: Equipment protection by
encapsulation "m"

(IEC 60079-18:2014)

Atmosphères explosives - Partie 18: Protection du matériel
par encapsulage "m"
(IEC 60079-18:2014)

Explosionsgefährdete Bereiche - Teil 18: Geräteschutz
durch Vergusskapselung "m"
(IEC 60079-18:2014)

This European Standard was approved by CENELEC on 2015-01-15. CENELEC members are bound to comply with the CEN/CENELEC Internal Regulations which stipulate the conditions for giving this European Standard the status of a national standard without any alteration.

Up-to-date lists and bibliographical references concerning such national standards may be obtained on application to the CEN-CENELEC Management Centre or to any CENELEC member.

This European Standard exists in three official versions (English, French, German). A version in any other language made by translation under the responsibility of a CENELEC member into its own language and notified to the CEN-CENELEC Management Centre has the same status as the official versions.

CENELEC members are the national electrotechnical committees of Austria, Belgium, Bulgaria, Croatia, Cyprus, the Czech Republic, Denmark, Estonia, Finland, Former Yugoslav Republic of Macedonia, France, Germany, Greece, Hungary, Iceland, Ireland, Italy, Latvia, Lithuania, Luxembourg, Malta, the Netherlands, Norway, Poland, Portugal, Romania, Slovakia, Slovenia, Spain, Sweden, Switzerland, Turkey and the United Kingdom.



European Committee for Electrotechnical Standardization
Comité Européen de Normalisation Electrotechnique
Europäisches Komitee für Elektrotechnische Normung

CEN-CENELEC Management Centre: Avenue Marnix 17, B-1000 Brussels

Foreword

The text of document 31/1152/FDIS, future edition 4 of IEC 60079-18, prepared by IEC/TC 31 "Equipment for explosive atmospheres" was submitted to the IEC-CENELEC parallel vote and approved by CENELEC as EN 60079-18:2015.

The following dates are fixed:

- latest date by which the document has to be (dop) 2015-10-21
implemented at national level by
publication of an identical national
standard or by endorsement
- latest date by which the national (dop) 2018-01-16
standards conflicting with the
document have to be withdrawn

This document supersedes EN 60079-18:2009.

Attention is drawn to the possibility that some of the elements of this document may be the subject of patent rights. CENELEC [and/or CEN] shall not be held responsible for identifying any or all such patent rights.

This document has been prepared under a mandate given to CENELEC by the European Commission and the European Free Trade Association, and supports essential requirements of EU Directive.

For the relationship with EU Directive see informative Annex ZZ, which is an integral part of this document.

Endorsement notice

The text of the International Standard IEC 60079-18:2014 was approved by CENELEC as a European Standard without any modification.

IEC 60079-1	NOTE	Harmonized as EN 60079-1.
IEC 60079-2	NOTE	Harmonized as EN 60079-5.
IEC 60079-5	NOTE	Harmonized as EN 60079-5.
IEC 60079-6	NOTE	Harmonized as EN 60079-6.
IEC 60079-10-1	NOTE	Harmonized as EN 60079-10-1.
IEC 60079-10-2	NOTE	Harmonized as EN 60079-10-2.
IEC 60079-14	NOTE	Harmonized as EN 60079-14.
IEC 60079-28	NOTE	Harmonized as EN 60079-28.
IEC 60086-1	NOTE	Harmonized as EN 60086-1.
IEC 60622	NOTE	Harmonized as EN 60622.
IEC 60604-1	NOTE	Harmonized as EN 60604-1.
IEC 60747-5-5	NOTE	Harmonized as EN 60747-5-5.
IEC 61951-1	NOTE	Harmonized as EN 61951-1.
IEC 61951-2	NOTE	Harmonized as EN 61951-2.
ISO 13849-1	NOTE	Harmonized as EN ISO 13849-1.

Annex ZA
(normative)

**Normative references to international publications
with their corresponding European publications**

The following documents, in whole or in part, are normatively referenced in this document and are indispensable for its application. For dated references, only the edition cited applies. For undated references, the latest edition of the referenced document (including any amendments) applies.

NOTE 1 When an International Publication has been modified by common modifications, indicated by (mod), the relevant EN/HD applies.

NOTE 2 Up-to-date information on the latest versions of the European Standards listed in this annex is available here: www.cenelec.eu.

<u>Publication</u>	<u>Year</u>	<u>Title</u>	<u>EN/HD</u>	<u>Year</u>
IEC 60079-0 (mod)	-	Explosive atmospheres -- Part 0: Equipment - General requirements	EN 60079-0 +A11	- 2013
IEC 60079-7	-	Explosive atmospheres -- Part 7: Equipment protection by increased safety "e"	EN 60079-7	-
IEC 60079-11	-	Explosive atmospheres -- Part 11: Equipment protection by intrinsic safety "i"	EN 60079-11	-
IEC 60079-15	-	Explosive atmospheres -- Part 15: Equipment protection by type of protection "n"	EN 60079-15	-
IEC 60079-26	-	Explosive atmospheres -- Part 26: Equipment with equipment protection level (EPL) Ga	EN 60079-26	-
IEC 60079-31	-	Explosive atmospheres -- Part 31: Equipment dust ignition protection by enclosure "t"	EN 60079-31	-
IEC 60127	series	Miniature fuses -- Part 1: Definitions for miniature fuses and general requirements for miniature fuse-links	EN 60127	series
IEC 60243-1	-	Electric strength of insulating materials - Test methods -- Part 1: Tests at power frequencies	EN 60243-1	-
IEC 60691	-	Thermal-links - Requirements and application guide	EN 60691	-
IEC 60730-2-9 (mod)	-	Automatic electrical controls for household and similar use - Part 2-9: Particular requirements for temperature sensing controls	EN 60730-2-9	-
IEC 60738-1	-	Thermistors - Directly heated positive temperature coefficient -- Part 1: Generic specification	+AA EN 60738-1	-
IEC 61140	-	Protection against electric shock - Common aspects for installation and equipment	EN 61140	-
IEC 61558-1	-	Safety of power transformers, power supplies, reactors and similar products -- Part 1: General requirements and tests	EN 61558-1	-
			+EN 61558-1:2005/corrigendum Aug. 2006	2006
IEC 61558-2-6	-	Safety of transformers, reactors, power supply units and similar products for supply voltages up to 1 100 V -- Part 2-6: Particular requirements and tests for safety isolating transformers and power supply units incorporating safety isolating transformers	EN 61558-2-6	-

IEC 62326-4-1 - Printed boards -- Part 4: Rigid multilayer printed boards with interlayer connections - Sectional specification -- Section 1: Capability Detail Specification - Performance levels A, B and C EN 62326-4-1 -

<http://www.china-gauges.com/>

Annex ZZ (informative)

Coverage of Essential Requirements of EC Directives

This European Standard has been prepared under a mandate given to CENELEC by the European Commission and the European Free Trade Association and within its scope the standard covers only the following essential requirements out of those given in Annex II of the EC Directive 94/9/EC:

- ER 1.0.1, ER 1.0.2 (partly), ER 1.0.4 (partly), ER 1.0.5 (partly)
- ER 1.1 (partly)
- ER 1.2.4, ER 1.2.8 (partly)
- ER 1.3.1 (partly), ER 1.3.3 (partly), ER 1.3.4 (partly)
- ER 1.4.1 (partly), ER 1.4.2 (partly)
- ER 1.5.1, ER 1.5.2
- ER 1.6.4 (partly),
- ER 2.0.1 (partly)
- ER 2.0.2.1 (partly), ER 2.0.2.3 (partly)
- ER 2.1.1.1 (partly), ER 2.1.1.2 (partly)
- ER 2.1.2.1 (partly), ER 2.1.2.2 (partly), ER 2.1.2.3 (partly)
- ER 2.2.1.1 (partly), ER 2.2.1.2 (partly)
- ER 2.2.2.1 (partly), ER 2.2.2.2 (partly)
- ER 2.3.1.1, ER 2.3.1.2
- ER 2.3.2.1, ER 2.3.2.2

Compliance with this standard provides one means of conformity with the specified essential requirements of the Directive[s] concerned.

WARNING: Other requirements and other EC Directives may be applicable to the products falling within the scope of this standard.

CONTENTS

FOREWORD	ii
1 Scope	12
2 Normative references	12
3 Terms and definitions	13
4 General	14
4.1 Level of protection (equipment protection level (EPL))	14
4.2 Additional requirements for levels of protection “ma” and “mb”	14
4.3 Additional requirements for level of protection “ma”	14
4.4 Rated voltage and prospective short circuit current	15
5 Requirements for components	15
5.1 General	15
5.2 Specification	15
5.3 Properties of the compound	15
5.3.1 Water absorption	15
5.3.2 Dielectric strength	15
6 Temperatures	16
6.1 General	16
6.2 Determination of the limiting temperatures	16
6.2.1 Maximum surface temperature	16
6.2.2 Temperature of the compound	16
6.3 Temperature limitation	16
7 Constructional requirements	16
7.1 General	16
7.2 Determination of faults	17
7.2.1 Fault examination	17
7.2.2 Components considered as not subject to fail	17
7.2.3 Isolating components	18
7.2.4 Infallible separation distances	18
7.3 Free space in the encapsulation	19
7.3.1 Group III “m” equipment	19
7.3.2 Group I and Group II “m” equipment	20
7.4 Thickness of the compound	21
7.4.1 “m” equipment	21
7.4.2 Windings for electrical machines	23
7.4.3 Rigid, multi-layer printed wiring boards with through connections	23
7.5 Switching contacts	24
7.5.1 General	24
7.5.2 Level of protection “ma”	25
7.5.3 Level of protection “mb”	25
7.5.4 Level of protection “mc”	25
7.6 External connections	25
7.6.1 General	25
7.6.2 Additional requirements for “ma” equipment	25
7.7 Protection of bare live parts	25
7.8 Cells and batteries	25
7.8.1 General	25

7.8.2	Prevention of gassing	26
7.8.3	Protection against inadmissible temperatures and damage to the cells or batteries	26
7.8.4	Reverse current	26
7.8.5	Current limitation	27
7.8.6	Protection against the polarity inversion and deep discharge of the cells	27
7.8.7	Charging of cells or batteries	27
7.8.8	Requirements for control safety devices for cells or batteries	28
7.9	Protective devices	28
7.9.1	General	28
7.9.2	Electrical protective devices	29
7.9.3	Thermal protective devices	29
7.9.4	Built-in protective devices	30
8	Type tests	30
8.1	Tests on the compound	30
8.1.1	Water absorption test	30
8.1.2	Dielectric strength test	30
8.2	Tests on the apparatus	30
8.2.1	Test sequence	30
8.2.2	Maximum temperature	31
8.2.3	Thermal endurance test	31
8.2.4	Dielectric strength test	32
8.2.5	Cable pull test	32
8.2.6	Pressure test for Group I and Group II electrical equipment	33
8.2.7	Test for resettable thermal protective device	34
8.2.8	Sealing test for built-in protective devices	34
9	Routine verifications and tests	34
9.1	Visual inspections	34
9.2	Dielectric strength test	34
10	Marking	35
	Annex A (informative) Basic requirements for compounds for "m" equipment	36
	Annex B (informative) Allocation of test samples	37
	Bibliography	38
	Figure 1 – Dimensional key for thickness through the compound	22
	Figure 2 – Minimum distances for multi-layer printed wiring boards	24
	Figure 3 – Fitting of blocking diodes	27
	Figure A.1 – Basic requirements for compounds for "m" equipment	36
	Table 1 – Distances through the compound	19
	Table 2 – Minimum thickness of compound adjacent to free space for Group III "m" equipment	20
	Table 3 – Minimum thickness of compound adjacent to free space for Group I and Group II "m" equipment	21
	Table 4 – Thickness of the compound	23

Table 5 – Minimum distances for multi-layer printed wiring boards 24
Table 6 – Test pressure 33
Table B.1 – Allocation of test samples 37

<http://www.china-gauges.com/>

INTERNATIONAL ELECTROTECHNICAL COMMISSION

EXPLOSIVE ATMOSPHERES –

Part 18: Equipment protection by encapsulation “m”

FOREWORD

- 1) The International Electrotechnical Commission (IEC) is a worldwide organization for standardization comprising all national electrotechnical committees (IEC National Committees). The object of IEC is to promote international co-operation on all questions concerning standardization in the electrical and electronic fields. To this end and in addition to other activities, IEC publishes International Standards, Technical Specifications, Technical Reports, Publicly Available Specifications (PAS) and Guides (hereafter referred to as “IEC Publication(s)”). Their preparation is entrusted to technical committees; any IEC National Committee interested in the subject dealt with may participate in this preparatory work. International, governmental and non-governmental organizations liaising with the IEC also participate in this preparation. IEC collaborates closely with the International Organization for Standardization (ISO) in accordance with conditions determined by agreement between the two organizations.
- 2) The formal decisions or agreements of IEC on technical matters express, as nearly as possible, an international consensus of opinion on the relevant subjects since each technical committee has representation from all interested IEC National Committees.
- 3) IEC Publications have the form of recommendations for international use and are accepted by IEC National Committees in that sense. While all reasonable efforts are made to ensure that the technical content of IEC Publications is accurate, IEC cannot be held responsible for the way in which they are used or for any misinterpretation by any end user.
- 4) In order to promote international uniformity, IEC National Committees undertake to apply IEC Publications transparently to the maximum extent possible in their national and regional publications. Any divergence between any IEC Publication and the corresponding national or regional publication shall be clearly indicated in the latter.
- 5) IEC itself does not provide any attestation of conformity. Independent certification bodies provide conformity assessment services and, in some areas, access to IEC marks of conformity. IEC is not responsible for any services carried out by independent certification bodies.
- 6) All users should ensure that they have the latest edition of this publication.
- 7) No liability shall attach to IEC or its directors, employees, servants or agents including individual experts and members of its technical committees and IEC National Committees for any personal injury, property damage or other damage of any nature whatsoever, whether direct or indirect, or for costs (including legal fees) and expenses arising out of the publication, use of, or reliance upon, this IEC Publication or any other IEC Publications.
- 8) Attention is drawn to the Normative references cited in this publication. Use of the referenced publications is indispensable for the correct application of this publication.
- 9) Attention is drawn to the possibility that some of the elements of this IEC Publication may be the subject of patent rights. IEC shall not be held responsible for identifying any or all such patent rights.

Standard IEC 60079-18 has been prepared by IEC technical committee 31: Equipment for explosive atmospheres.

This fourth edition cancels and replaces the third edition of IEC 60079-18 (2009), and constitutes a technical revision.

This International Standard is to be used in conjunction with IEC 60079-0, *Explosive atmospheres – Part 0: Equipment-General requirements*.

This edition includes the following significant technical changes with respect to the previous edition:

Explanation of the significance of the changes	Clause	Type		
		Minor and editorial changes	Extension	Major technical changes
Definitions deleted and moved to IEC 60079-0	3	X		
Heading modified /added to clarify which requirements are additional requirements for “ma” level of protection only	4			
Thermal conductivity added	5.2		X	
Note added that it is not a requirement of this standard that conformity to the manufacturer’s specification of the compound needs to be verified	5.3.2	X		
Clarification added	6.2.2	X		
Clarification added	7.1	X		
For the determination of faults options added and clarification given	7.2		X	
Additional information included in Figure 1	7.4.1	X		
“Varnish and similar coatings are not considered to be solid insulation.” was added in this section and deleted in the definition on 3.8	7.4.2	X		
For rigid, multi-layer printed wiring boards with through connections additional standards added	7.4.3.1		X	
Protection against inadmissible temperatures and damage to the cells	7.8.3			C1
Electrical protective devices clarified and additional possibilities added	7.9.2		X	
Thermal protective devices clarified and additional possibilities added	7.9.3		X	
2/3 voltage limitation deleted	7.9.3		X	
Determination of the maximum temperature for “Da” fixed	8.2.2			C2
Stabilization of the temperature	8.2.2			C3
Thermal endurance to heat	8.2.3.1		X	
Temperature fixed as reference service temperatures and tests given as alternatives	8.2.3.1.1		X	
For the dielectric strength test procedure alternative possibilities added	8.2.4.1		X	
Alternative test methods for the required pressure test for Group I and Group II electrical equipment added	8.2.6		X	
Sealing test for build-in protective devices	8.2.8		X	
For the dielectric strength test procedure alternative possibilities added	9.2		X	
Marking	10	X	X	

Explanation of the Types of Significant Changes:

A) Definitions

1. Minor and editorial changes:

- Clarification
- Decrease of technical requirements
- Minor technical change
- Editorial corrections

These are changes which modify requirements in an editorial or a minor technical way. They include changes of the wording to clarify technical requirements without any technical change, or a reduction in level of existing requirement.

2. Extension:

- Addition of technical options

These are changes which add new or modify existing technical requirements, in a way that new options are given, but without increasing requirements for equipment that was fully compliant with the previous standard. Therefore, these will not have to be considered for products in conformity with the preceding edition.

3. Major technical changes:

- addition of technical requirements
- increase of technical requirements

These are changes to technical requirements (addition, increase of the level or removal) made in a way that a product in conformity with the preceding edition will not always be able to fulfil the requirements given in the later edition. These changes have to be considered for products in conformity with the preceding edition. For these changes additional information is provided in item B) below.

Note These changes represent current technological knowledge. However, these changes should not normally have an influence on equipment already placed on the market.

B) Information about the background of 'Major technical changes'

C1 Clause 7.8.3 modified and additional requirements added for cells or batteries

C2 The flexibility given in IEC 60079-0 is replaced by a min. requirement. For level of protection "ma" equipment, designed for EPL "Da" the maximum surface temperature shall be determined with the equipment mounted in accordance with the manufacturer's instructions, and surrounded on all available surfaces by dust with a layer thickness of at least 200 mm

C3 The increase of the temperature during the test can be a very slow process. The final temperature shall be considered to have been reached when the rate of rise of temperature does not exceed 1 K/24 h

The text of this standard is based on the following documents:

FDIS	Report on voting
31/1152/FDIS	31/1168/RVD

Full information on the voting for the approval of this standard can be found in the report on voting indicated in the above table.

This publication has been drafted in accordance with the ISO/IEC Directives, Part 2.

A list of all the parts in the IEC 60079 series, published under the general title *Explosive atmospheres*, can be found on the IEC website.

The committee has decided that the contents of this publication will remain unchanged until the stability date indicated on the IEC website under "http://webstore.iec.ch" in the data related to the specific publication. At this date, the publication will be

- reconfirmed,
- withdrawn,
- replaced by a revised edition, or
- amended.

EXPLOSIVE ATMOSPHERES –

Part 18: Equipment protection by encapsulation “m”

1 Scope

This part of IEC 60079 gives the specific requirements for the construction, testing and marking of electrical equipment, parts of electrical equipment and Ex components with the type of protection encapsulation “m” intended for use in explosive gas atmospheres or explosive dust atmospheres.

This part applies only for encapsulated electrical equipment, encapsulated parts of electrical equipment and encapsulated Ex components (hereinafter always referred to as “m” equipment) where the rated voltage does not exceed 11 kV.

The application of electrical equipment in atmospheres, which may contain explosive gas as well as combustible dust simultaneously, may require additional protective measures.

This standard does not apply to dusts of explosives, which do not require atmospheric oxygen for combustion, or to pyrophoric substances

This standard does not take account of any risk due to an emission of flammable or toxic gas from the dust.

This standard supplements and modifies the general requirements of IEC 60079-0. Where a requirement of this standard conflicts with a requirement of IEC 60079-0, the requirement of this standard takes precedence.

2 Normative references

The following documents, in whole or in part, are normatively referenced in this document and are indispensable for its application. For dated references, only the edition cited applies. For undated references, the latest edition of the referenced document (including any amendments) applies.

IEC 60079-0, *Explosive atmospheres – Part 0: Equipment – General requirements*

IEC 60079-7, *Explosive atmospheres – Part 7: Equipment protection by increased safety “e”*

IEC 60079-11, *Explosive atmospheres – Part 11: Equipment protection by intrinsic safety “i”*

IEC 60079-15, *Explosive atmospheres – Part 15: Equipment protection by type of protection “n”*

IEC 60079-26, *Explosive atmospheres – Part 26: Equipment with equipment protection level (EPL) Ga*

IEC 60079-31, *Explosive atmospheres – Part 31: Equipment dust ignition protection by enclosure “t”*

IEC 60127 (all parts), *Miniature fuses*

IEC 60243-1, *Electrical strength of insulating materials – Test methods – Part 1: Tests at power frequencies*

IEC 60691, *Thermal-links – Requirements and application guide*

IEC 60730-2-9, *Automatic electrical controls for household and similar use – Part 2-9: Particular requirements for temperature sensing controls*

IEC 60738-1, *Thermistors – Directly heated positive temperature coefficient – Part 1: Generic specification*

IEC 61140, *Protection against electric shock – Common aspects for installation and equipment*

IEC 61558-1, *Safety of power transformers, power supplies, reactors and similar products – Part 1: General requirements and tests*

IEC 61558-2-6, *Safety of transformers, reactors, power supply units and similar products for supply voltages up to 1 100 V – Part 2-6: Particular requirements and tests for safety isolating transformers and power supply units incorporating safety isolating transformers*

IEC 62326-4-1, *Printed boards – Part 4: Rigid multilayer printed boards with interlayer connections – Sectional specification – Section 1: Capability detail specification – Performance levels A, B and C*

ANSI/UL 248 (all parts), *Standard for low-voltage fuses*

ANSI/UL 746B, *Standard for polymeric materials – Long term property evaluations*

ANSI/UL 796, *Printed-Wiring Boards*

IPC-A-600, *Acceptability of Printed Boards*

IPC-6012, *Qualification and Performance Specification for Rigid Printed Boards*

3 Terms and definitions

For the purposes of this document, the terms and definitions given in IEC 60079-0 and the following definitions apply.

NOTE Additional definitions applicable to explosive atmospheres can be found in IEC 60050-426.

3.1

encapsulation “m”

type of protection whereby parts that are capable of igniting an explosive atmosphere by either sparking or heating are fully enclosed in a compound or other non-metallic enclosure with adhesion in such a way as to avoid ignition of a dust layer or explosive atmosphere under operating or installation conditions

3.2

temperature range of the compound

range of temperatures within which the properties of the compound, in either operation or storage, permit compliance with the requirements of IEC 60079-18

3.3

free surface

compound surface exposed to the explosive atmospheres and/or dust layers

3.4

switching contact

mechanical contact, which makes and breaks an electrical circuit

3.5

adhesion

moisture, gas and dust tight permanent bonding of a compound to a surface

3.6

countable fault

fault which occurs in parts of electrical equipment conforming to the constructional requirements

3.7

infallible separation

separation between electrically conductive parts that is considered as not subject to short circuits

3.8

solid insulation

insulation material which is extruded or moulded, but not poured

Note 1 to entry: Insulators fabricated from two or more pieces of electrical insulating material, which are solidly bonded together may be considered as solid.

4 General

4.1 Level of protection (equipment protection level (EPL))

Electrical equipment with encapsulation “m” shall be either:

- a) level of protection “ma” (EPL “Ma, Ga, Da”),
- b) level of protection “mb” (EPL “Mb, Gb, Db”), or
- c) level of protection “mc” (EPL “Gc, Dc”).

The requirements of this standard apply to all levels of protection for encapsulation “m” unless otherwise stated.

4.2 Additional requirements for levels of protection “ma” and “mb”

Components without additional protection shall be used only if they cannot damage the encapsulation mechanically or thermally in the case of any fault conditions specified in this standard.

Alternatively, where a fault of an internal component may lead to failure of encapsulation “m” due to increasing temperature, the requirements of 7.9 shall apply.

4.3 Additional requirements for level of protection “ma”

The working voltage at any point in the circuit shall not exceed 1 kV.

4.4 Rated voltage and prospective short circuit current

The rated voltage and the prospective short circuit current shall be specified such that the limiting temperature is not exceeded for the relevant level of protection “ma”, “mb” or “mc”.

5 Requirements for compounds

5.1 General

The documentation shall specify the compound(s) used and the processing method(s), including measures to prevent the formation of voids.

As a minimum, those properties of the compound(s) on which encapsulation “m” depends shall be provided.

NOTE Proper selection of the compound allows for the expansion of components during operation and in the event of allowable faults.

5.2 Specification

The specification for the compound shall include the following:

- a) the name and address of the manufacturer of the compound,
- b) the exact and complete reference of the compound and if relevant, percentage of fillers and any other additives, the mixture ratios and the type designation,
- c) if applicable, any treatment of the surface of the compound(s), for example varnishing,
- d) if applicable, to obtain correct adhesion of the compound to a component, any requirement for pre-treating of the component for example cleaning, etching,
- e) the dielectric strength in accordance with IEC 60243-1 at the maximum service temperature of the compound determined according to 8.2.2 a) if available; if not available, the requirements of 5.3.2 shall be applied,
- f) temperature range of the compound(s) (including maximum continuous operating temperature (COT) and minimum continuous operating temperature (COT)),
- g) in the case of “m” equipment where the compound is part of the external enclosure, the temperature index TI value as defined by IEC 60079-0. As an alternative to the TI, the relative thermal index (RTI-mechanical) may be determined in accordance with ANSI/UL 746B,
- h) the colour of the compound used for the test samples, where the compound specification will be influenced by changing the colour,
- i) Thermal conductivity if utilizing the alternative test method in 6.2.2.

NOTE It is not a requirement of this standard that conformity to the manufacturer’s specification of the compound needs to be verified.

5.3 Properties of the compound

5.3.1 Water absorption

Either the compound shall be tested in accordance with 8.1.1 or, if this test is not performed, the certificate number for the equipment shall include the “X” suffix in accordance with the marking requirements of IEC 60079-0 and the specific conditions of use listed on the certificate shall detail the precautions necessary.

5.3.2 Dielectric strength

Where the dielectric strength according to IEC 60243-1 at the maximum service temperature according to 8.2.2 a), of the compound is not available from the material manufacturer, a test shall be performed in accordance with 8.1.2.

NOTE It is not a requirement of this standard that conformity to the manufacturer's specification of the compound needs to be verified.

6 Temperatures

6.1 General

The service temperature of the compound, determined in accordance with IEC 60079-0, shall not exceed the maximum value of the COT of the compound. The maximum surface temperature shall be determined in accordance with IEC 60079-0 under normal operation and under fault conditions as defined in 7.2.1. The "m" equipment shall be protected in such a way that encapsulation "m" is not adversely affected under these fault conditions.

6.2 Determination of the limiting temperatures

6.2.1 Maximum surface temperature

The maximum surface temperature shall be determined using the test method given in 8.2.2 in accordance with the supply conditions specified in 4.4.

NOTE This temperature is used to determine either the temperature class for explosive gas atmospheres or the maximum surface temperature in degree Celsius for explosive dust atmospheres of the equipment, or both.

6.2.2 Temperature of the compound

The hottest component shall be determined. The maximum temperature in the compound, adjacent to the hottest component, shall be determined using the test method given in 8.2.2 for normal operation.

As an alternative the determination of the temperature of the hottest component in normal operation may be done by calculation, manufacturer's specification or by testing the component under intended application conditions prior to encapsulating the component if the thermal conductivity of the compound is greater than that of air.

NOTE Thermal conductivity of air is most often defined as 0.25 W/m²K (standard conditions).

6.3 Temperature limitation

Where the equipment may be subject to fault in accordance with 7.2.1, or where there is the possibility of an increased temperature, for example by an unfavourable input voltage in accordance with 7.2.1 or an unfavourable load, this shall be taken into account in determining the limiting temperatures.

When a protective device is required to limit temperatures for safety reasons, it shall be an electrical or thermal device external to the equipment or directly integrated into the equipment, as defined in 7.9.

7 Constructional requirements

7.1 General

Where the compound forms part of the external enclosure it shall comply with the requirements of IEC 60079-0 for non metallic enclosures and non metallic parts of enclosures.

If the surface of the compound is totally or partly surrounded by an enclosure and the enclosure is part of the protection, the enclosure or parts of the enclosure shall comply with the enclosure requirements of IEC 60079-0.

Additional protective measures may be required to be provided by the user in the installation in order to comply with the requirements of this standard. For example, additional mechanical

protection may be required to protect the equipment from a direct impact. In such cases, the certificate number for the equipment shall include the “X” suffix in accordance with the marking requirements of IEC 60079-0 and the specific conditions of use listed in the certificate shall detail the precautions necessary.

Appropriate action shall be taken to accommodate the expansion of components during normal operation and in the event of faults according to 7.2.

In 7.2 to 7.9 the requirements differ according to whether the compound adheres to the enclosure. Where adhesion is specified, the aim is to prevent the ingress of explosive atmospheres and moisture at the boundary surfaces (for example enclosure-compound, compound-parts that are not completely embedded in the compound, such as printed wiring boards, connection terminals, etc.). Where adhesion is required to maintain the type of protection, it shall be maintained after completion of all the prescribed tests. The choice of the compound(s) to be used for a specific application is dependent on the task each compound has to perform. Testing a compound once for a given application will not qualify that compound for all applications.

NOTE Tests for adhesion are under consideration.

7.2 Determination of faults

7.2.1 Fault examination

When tested in accordance with IEC 60079-0, encapsulation “m” shall be maintained in the case of

- a) the most unfavourable output load and
- b) up to two internal countable faults for level of protection “ma”, and up to one internal countable fault for level of protection “mb”, taking into account 7.2.2, 7.2.3 and 7.2.4.

No faults are taken into account for level of protection “mc”.

NOTE Examples of faults are: a short circuit in any component, the failure of any component and a fault between tracks in the printed wiring board, but not the opening of a track.

The failure of some components may result in an unstable condition, for example, alternating between high and low resistance. In those cases, the most onerous condition shall be considered.

If a fault leads to one or more subsequent faults, for example, due to the overload of a component, the primary and subsequent fault(s) shall be considered to be a single fault.

7.2.2 Components considered as not subject to fail

For levels of protection “ma” and “mb” the following components shall be considered as not to fail if they are encapsulated according to the requirements of this standard, if they are suitable for the service temperature and if they are not operated at more than 2/3 of their rated voltage, rated current and rated power related to the rating of the device, the mounting conditions and the temperature range specified:

- resistors,
- single-layer, spirally wound coils,
- plastic foil capacitors,
- paper capacitors,
- ceramic capacitors,
- semiconductors,
- semiconductor devices used as a protective device according to 7.9,

- resistors used as a protective device according to 7.9, if they comply with the current limiting resistors of IEC 60079-11 for level of protection “ia” or “ib”.

For levels of protection “ma” and “mb” windings that comply with IEC 60079-7, including also those that have wire diameters of less than 0,25 mm shall be considered as not subject to failure if they are encapsulated according to the requirements of this standard.

7.2.3 Isolating components

The following components for the segregation of different circuits shall be considered to provide isolation and are not considered to fail across the segregation:

- Galvanically separating components (e.g. optocouplers and relays),
 - if the rated insulation voltage conforms to $2U + 1\,000\text{ V r.m.s. } +5\%_0$ or $1\,500\text{ V r.m.s.}$ whichever is greater (U is the sum of the rated r.m.s. voltages of both circuits), or
 - for a rated insulation voltage across the segregation of more than 60 V (sum of the rated r.m.s. voltages of both circuits), optocouplers and relays providing a double or reinforced insulation between the circuits per IEC 61140, or
 - complying with IEC 60079-11 for level of protection “ia” or “ib”.
- Transformers,
 - complying with IEC 61558-2-6, or
 - providing a double or reinforced insulation between the circuit per IEC 61558-1, or
 - complying with IEC 60079-11 for level of protection “ia” or “ib”.

NOTE 1 It is not a requirement of this standard that conformity to the above standards per the manufacturer’s specification regarding segregation needs to be verified.

NOTE 2 Galvanically separating components providing double or reinforced insulation according to a product standard are considered to meet the requirements of IEC 61140 e.g. IEC 60747-5-5 for optocouplers.

7.2.4 Infallible separation distances

7.2.4.1 General

It is not necessary to consider the possibility of a fault occurring as described in 7.2.1 in respect of voltage breakdown, if the distances between bare current-carrying parts:

- of the same circuit, or
- of a circuit and earthed metal parts, or
- of two separate circuits (sum of the working voltages shall be taken as the voltage for Table 1; where one of the working voltages is less than 20 % of the other, it shall be ignored),

comply with the requirements of 7.2.4.2 and if applicable 7.2.4.3.

7.2.4.2 Distances through the compound

Distances through compound shall be considered to be infallible against short circuit for level of protection “ma” and level of protection “mb” if they comply with the values in Table 1, provided that the distances in the compound are fixed or secured mechanically before encapsulation.

NOTE When a suitably adhered non-metallic enclosure of a given specific minimum thickness permits a zero thickness of compound per Key letter c of Table 4 and Figure 1, then the separation distances for the associated current carrying parts are still considered infallible against short circuit

Distances between the minimum distances given for level of protection “mc” and the infallible distances given for level of protection “ma” and “mb” are not considered infallible and shall be

assessed as a “countable fault”. Distances less than those given for level of protection “mc” are considered as short-circuits if this impairs the type of protection “m”.

For level of protection “mc” the values of Table 1 are the constructional requirements and may be achieved by mechanically fixing before encapsulation.

Table 1 – Distances through the compound

Voltage U r.m.s. or d.c. (see ^a) V	Minimum distance mm		
	“ma”	“mb”	“mc”
≤ 32	0,5	0,5	0,2
≤ 63	0,5	0,5	0,3
≤ 100	1	1	0,6
≤ 500	1,5	1,5	0,8
≤ 630	2	2	0,9
≤ 1 000	2,5	2,5	1,7
≤ 1 600	-	4	4
≤ 3 200	-	7	7
≤ 6 300	-	12	12
≤ 10 000	-	20	20

^a Voltages shown are derived from IEC 60664-1 and are based on the rationalization of supply voltages given in Table 3b of IEC 60664-1. When determining the required distance, the working voltage may be higher than the voltage in the table by a factor of 1,1.

NOTE The factor of 1,1 recognizes that at many places in a circuit, the working voltage equals the rated voltage and that there are a number of rated voltages in common use that can be accommodated by the 1,1 factor.

7.2.4.3 Distances through solid insulation

The distance through solid insulation, on which the type of protection “m” depends, shall be at least 0,1 mm and shall comply with the dielectric strength test of 8.2.4.

7.3 Free space in the encapsulation

7.3.1 Group III “m” equipment

The sum of the free spaces is not limited, but the volume of each individual free space is limited to 100 cm³. The thickness of the compound surrounding such free spaces shall meet the requirements of Table 2.

Table 2 – Minimum thickness of compound adjacent to free space for Group III “m” equipment

Level of protection	Minimum thickness of compound adjacent to free space to:	Free space $\leq 1 \text{ cm}^3$	Free space $> 1 \text{ cm}^3 \leq 100 \text{ cm}^3$
“ma”	Free space or free surface	3 mm	3 mm
	Non-metallic or metal enclosure with adhesion	3 mm (enclosure + compound) ^a	3 mm (enclosure + compound) ^a
	Non-metallic or metal enclosure without adhesion	3 mm	3 mm
“mb”	Free space or free surface	1 mm	3 mm
	Non-metallic or metal enclosure with adhesion	1 mm (enclosure + compound)	3 mm (enclosure + compound) ^a
	Non-metallic or metal enclosure without adhesion	1 mm	3 mm
“mc”	Free space or free surface	1 mm	1 mm
	Non-metallic or metal enclosure with adhesion	1 mm (enclosure + compound)	1 mm (enclosure + compound)
	Non-metallic or metal enclosure without adhesion	1 mm	1 mm
^a Wall thickness of the enclosure $\geq 1 \text{ mm}$.			
The thickness of the materials quoted in this table does not imply compliance with other mechanical tests required by IEC 60079-0.			
NOTE A metal enclosure with adhesion is permitted to have no compound thickness to a free space provided there are no live parts in the free space.			

7.3.2 Group I and Group II “m” equipment

The sum of the free spaces shall not exceed:

- 100 cm³ for level of protection “mb” and “mc”;
- 10 cm³ for level of protection “ma”.

The minimum thickness of the compound surrounding such free spaces shall comply with Table 3.

Table 3 – Minimum thickness of compound adjacent to free space for Group I and Group II “m” equipment

Level of protection	Minimum thickness of compound adjacent to free space to:	Free space $\leq 1 \text{ cm}^3$	Free space $> 1 \text{ cm}^3 \leq 10 \text{ cm}^3$	Free space $> 10 \text{ cm}^3 \leq 100 \text{ cm}^3$
“ma”	Free space or free surface	3 mm	3 mm (pressure test in accordance with 8.2.6)	Not permitted
	Non-metallic or metal enclosure with adhesion	3 mm (enclosure + compound) ^a	3 mm (enclosure + compound) ^a (pressure test in accordance with 8.2.6)	Not permitted
	Non-metallic or metal enclosure without adhesion	3 mm	3 mm (pressure test in accordance with 8.2.6)	Not permitted
“mb”	Free space or free surface	1 mm	3 mm	3 mm (pressure test in accordance with 8.2.6)
	Non-metallic or metal enclosure with adhesion	1 mm (enclosure + compound)	3 mm (enclosure + compound) ^a	3 mm (enclosure + compound) ^a (pressure test in accordance with 8.2.6)
	Non-metallic or metal enclosure without adhesion	1 mm	3 mm	3 mm (pressure test in accordance with 8.2.6)
“mc”	Free space or free surface	1 mm	1 mm	3 mm
	Non-metallic or metal enclosure with adhesion	1 mm (enclosure + compound)	1 mm (enclosure + compound)	3 mm (enclosure + compound) See note
	Non-metallic or metal enclosure without adhesion	1 mm	1 mm	3 mm
^a Wall thickness of the enclosure $\geq 1 \text{ mm}$.				
The thickness of the materials quoted in this table does not imply compliance with other mechanical tests required by IEC 60079-0.				
NOTE A metal enclosure with adhesion is permitted to have no compound thickness to a free space provided there are no live parts in the free space.				

7.4 Thickness of the compound

7.4.1 “m” equipment

The minimum thickness of compound surrounding the electrical components and circuit shall be in accordance with Table 4 and Figure 1.

If solid insulation according to 7.2.4.3 is used in an enclosure with metallic walls as shown in Figure 1, the compound shall adhere to the wall.

NOTE 1 Figure 1 does not necessarily represent a practical construction, but is intended to assist in understanding Table 4 by showing an encapsulated circuit that includes a free surface; a metallic enclosure; a plastic enclosure with different wall thicknesses.

When a suitably adhered non-metallic enclosure of a given specific minimum thickness permits a zero thickness of compound per Key letter c of Table 4 and Figure 1, then the separation distances for the associated current carrying parts are still considered infallible against short circuit.

NOTE 2 Separation distances (creepages and clearances) associated with such current carrying parts that are permitted to have zero thickness of compound and still be considered infallible against short circuit are evaluated in accordance with the applicable safety requirements of the relevant industrial standards.

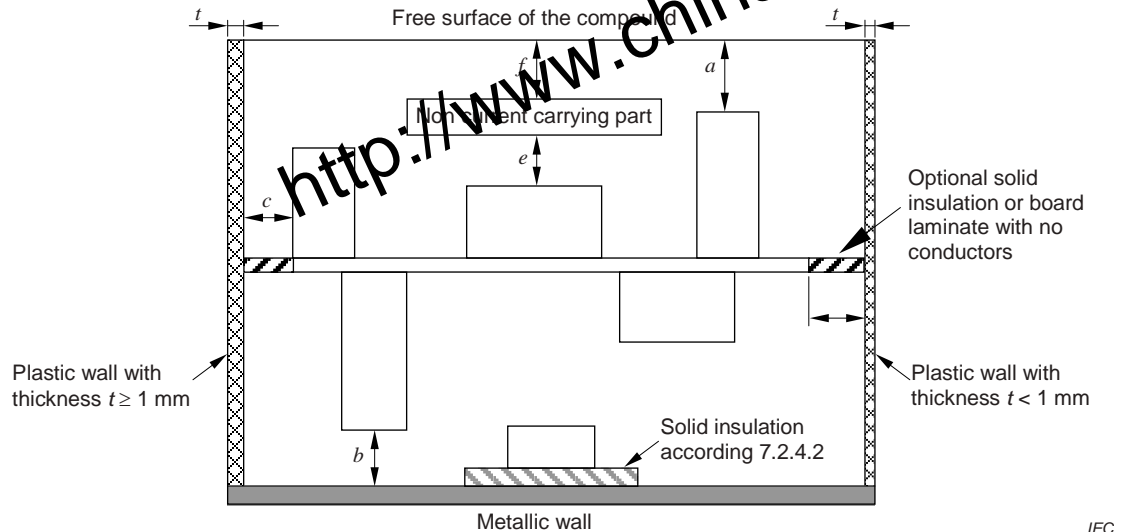

IEC

Key

- a* distance to free surface
- b* distance to metal enclosure
- c* distance to non metallic enclosure with wall thickness $t \geq 1$ mm
- d* distance to non metallic enclosure with wall thickness $t < 1$ mm
- e* distance to non current carrying part within the compound
- f* distance from non current carrying part to free surface

Figure 1 – Dimensional key for thickness through the compound

In all cases the compound shall be subjected to the dielectric strength test of 8.2.4.

Table 4 – Thickness of the compound

	Level of protection “ma”	Level of protection “mb” or “mc”
Free surface $\leq 2 \text{ cm}^2$	$a \geq 3 \text{ mm}$	$a \geq$ distance according to Table 1 but not less than 1 mm
Free surface $> 2 \text{ cm}^2$	$a \geq 3 \text{ mm}$	$a \geq$ distance according to Table 1 but not less than 3 mm
non metallic enclosure with adhesion (wall thickness $t < 1 \text{ mm}$)	$d \geq 3 \text{ mm}$	$d \geq$ distance according to Table 1 but not less than 1 mm
non metallic enclosure with adhesion (wall thickness $t \geq 1 \text{ mm}$)	$c \geq (3 \text{ mm} - t)$	$c \geq (\text{distance according to Table 1} - t)^a$
non metallic enclosure without adhesion	$c = d \geq 3 \text{ mm}$	$c = d \geq$ distance according to Table 1 but not less than 1 mm
Metal enclosure	$b \geq 3 \text{ mm}$	$b \geq$ distance according to Table 1 but not less than 1 mm
Non current carrying part	$e \geq 3 \text{ mm}$	$e \geq$ distance according to Table 1 but not less than 1 mm
Non current carrying part – free surface	$f + e \geq a$	$f + e \geq a$
^a In the case of non metallic enclosure with adhesion and wall thickness $\geq 1 \text{ mm}$ if the application of the formula allows $c = 0$ the component may be placed against the wall.		

7.4.2 Windings for electrical machines

For electrical machines with windings in slots, the solid slot insulation shall have:

- for level of protection “ma” only, a minimum thickness of 0,1 mm and shall be extended by at least 5 mm beyond the end of the slot;
- for levels of protection “ma” and “mb”, the end of the slot and the end-winding shall be protected by the minimum thickness of compound in accordance with 7.4.1. A dielectric strength test in accordance with 8.2.4 shall be passed with a test voltage $U = 2U + 1\,000 \text{ V r.m.s. } +5_0\%$ with a minimum of 1 500 V a.c. at 48 Hz to 62 Hz.

Varnish and similar coatings are not considered to be solid insulation.

7.4.3 Rigid, multi-layer printed wiring boards with through connections

7.4.3.1 General

Multi-layer printed wiring boards complying with the requirements of IEC 62326-4-1, performance level C or IPC-A-600 and IPC-6012 or ANSI/UL 796, operated at working voltages less than or equal to 500 V, shall be considered to be encapsulated providing they meet 7.4.3.2

NOTE It is not a requirement of this standard that conformity to the manufacturer’s performance specification of the printed wiring board needs to be verified.

7.4.3.2 Minimum distances

The insulation thickness of both, the copper-clad laminates and the adhesive films shall comply with the requirements of 7.2.4.3.

NOTE The insulation thickness is the combination of the laminate and the adhesive film when they are not separated by copper.

The minimum distance between the printed circuit conductors and the edge of the multi-layer printed wiring board or any hole in it shall be at least distance b of Table 5. If the edges or holes are protected with metal or insulating material extending at least 1 mm along the surface of the board from the edges or holes, the distance between the printed wiring conductors and the metal or insulating material may be reduced to distance c of Table 5. Metal coating shall have a minimum thickness of 35 μm (see also Figure 2 and Table 5).

Table 5 – Minimum distances for multi-layer printed wiring boards

Distance	Level of protection “ma”	Level of protection “mb”	Level of protection “mc”
a	3 mm	0,5 mm	0,25 mm
b	3 mm	3 mm	1 mm
c	3 mm	3 mm	0,5 mm
d	0,1 mm, see 7.2.4.3	0,1 mm, see 7.2.4.3	0,1 mm, see 7.2.4.3
e	In accordance with Table 1	In accordance with Table 1	In accordance with Table 1

where

a is the distance between the current carrying part and the outside surface through the cover layer;

b is the distance between the current carrying part and the outside surface along the cover layer;

c is the length of metal or insulation extending along the surface of the board from the edge or the hole;

d is the thickness of the adhesive film or the core where segregation is required;

e is the distance between two circuits inside the multilayer where segregation is required.

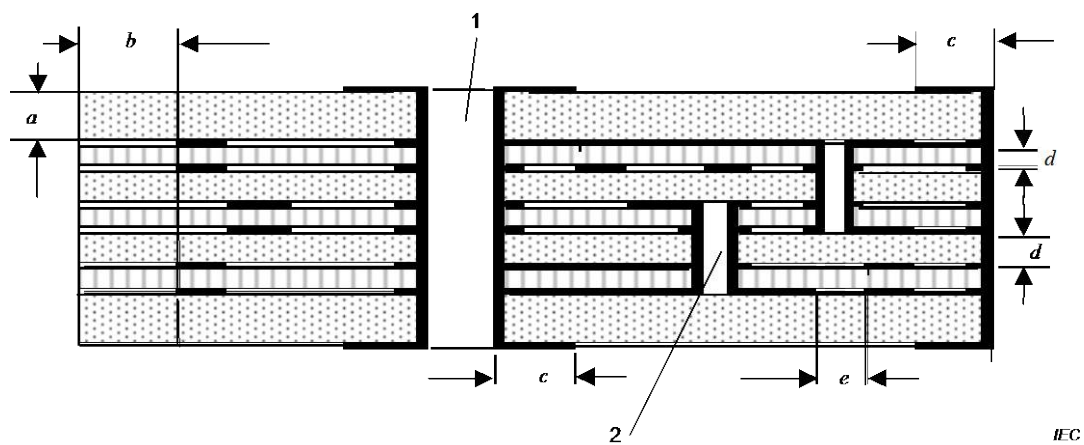

Key

core and cover layer



adhesive film



copper



1 Through contact for termination

2 Through contact to connect the printed conductors to the layers

Figure 2 – Minimum distances for multi-layer printed wiring boards

7.5 Switching contacts

7.5.1 General

Switching contacts shall be provided with an additional enclosure.

NOTE Entering of compound in the enclosure of the switching contacts during the encapsulation process can interfere with the function of the device

7.5.2 Level of protection “ma”

This additional enclosure shall be in accordance with the requirements for hermetically-sealed devices as defined in IEC 60079-15 before encapsulation.

NOTE Damage to the hermetically-sealed enclosure due to stresses during potting can invalidate the type of protection of the device.

The rating of switching contacts shall be less than or equal to 60 V and 6 A. The additional enclosure shall be made of inorganic material if the switched current exceeds 2/3 of the rated current specified by the manufacturer of the component.

7.5.3 Level of protection “mb”

This additional enclosure shall be made of inorganic material if the switched current exceeds 2/3 of the rated current specified by the manufacturer of the component or if the current exceeds 6 A.

7.5.4 Level of protection “mc”

This additional enclosure shall be made of inorganic material if the switched current exceeds 6 A.

7.6 External connections

7.6.1 General

When compounds are used to secure a permanently connected cable, the cable shall be suitably protected against damage from flexing and the pull test shall be carried out according to 8.2.5.

This test shall not be performed on Ex Components or where the enclosure of the “m” protected device does not serve as an external enclosure.

7.6.2 Additional requirements for “ma” equipment

The Ex ma equipment shall either be supplied by a circuit in accordance with level of protection “ia” according to IEC 60079-11 or have a connection in accordance with one of the following requirements:

- for EPL Ga requirements of IEC 60079-26;
- for EPL Da, level of protection “ta” of IEC 60079-31.

7.7 Protection of bare live parts

Depending on the required EPL bare live parts that pass through the surface of the compound shall be protected by another type of protection as listed in IEC 60079-0 for the required EPL.

NOTE In this case, the equipment is marked with multiple types of protection in accordance with IEC 60079-0.

7.8 Cells and batteries

7.8.1 General

When evaluating battery control arrangements with respect to the potential release of gas, the full range of operating temperatures, internal resistance and voltage capability shall be considered. It shall be assumed that batteries can become unbalanced, but cells with negligible resistance or voltage capability need not be taken into account.

Subclause 7.8 applies to all levels of protection, unless specifically excluded.

For level of protection “ma” cells and batteries shall additionally comply with the cell and battery requirements of IEC 60079-11 except for the relaxation for parallel cells, which are not permitted in equipment solely protected by encapsulation.

7.8.2 Prevention of gassing

Electrochemical systems that can release gas during normal operation are not permitted. If for levels of protection “ma” and “mb” the release of gas in the event of a fault cannot be precluded, the gassing shall be minimised by a control device in accordance with 7.8.8. With secondary cells, the control device shall be effective not only during charging, but also during discharging. This also applies for charging outside the hazardous area.

In particular,

- a) vented cells shall not be used,
- b) sealed valve regulated cells shall not be used,
- c) sealed gas-tight cells that, within the range of the ambient temperature of the electric equipment, do not release gas under any operating or fault conditions may be used without a control device in accordance with 7.8.8.

Gas-tight cells that do not fulfil the requirements of 7.8.2 c) shall have a control device in accordance with 7.8.8.

7.8.3 Protection against inadmissible temperatures and damage to the cells or batteries

The maximum service temperature of the cells or batteries under worst case load (see 7.8.5) shall not exceed either the temperature specified by the manufacturer of the cells or batteries, or 80 °C if not specified by the manufacturer and the maximum charging and discharging current shall not exceed the safe value specified by the manufacturer by one of the following means:

- a) shall be provided with one or more control devices as described in 7.8.8 to prevent unacceptable overheating or gassing inside the compound,
- b) shall be provided with a series resistor to limit current to the cell rating and a blocking diode to preclude reverse charging.

In either case, the requirements in 7.8.4 through 7.8.7 apply as applicable.

7.8.4 Reverse current

For levels of protection “ma” and “mb” where there is another voltage source in the same enclosure, the encapsulated cell or battery and its associated circuits shall be protected against charging by circuits other than those specifically designed for charging. For example, by separating the cell or battery and its associated circuits from all other voltage source(s) inside the enclosure, using the distances specified in Table 1 for the highest voltage capable of causing the reverse current. Alternatively, the cell or battery only may be separated, from the other voltage source(s) using the distances specified in Table 1, but with one blocking diode for level of protection “mb”, or two blocking diodes for level of protection “ma”, fitted as shown in Figure 3, and so arranged as to reduce the risk of a single fault causing both diodes to be short-circuited.

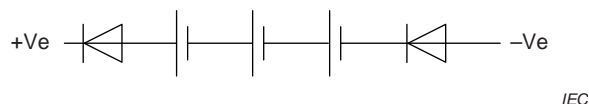

NOTE Figure shows arrangement for Level of Protection “ma”.

Figure 3 – Fitting of blocking diodes

7.8.5 Current limitation

The maximum surface temperature shall be determined using the highest discharge current permitted by the maximum load specified by the equipment manufacturer, or by the protective device, see 7.9, for example 1,7 times the rating of the fuse, or at short circuit if neither a load nor a protective device is specified.

A resistor, a current limiting device or a fuse according to IEC 60127 or IEC 60691 or ANSI/UL 248 series may be used to ensure the maximum discharge current specified by the manufacturer of the cells or battery is not exceeded. If replaceable fuses are used the equipment shall be marked to show their rating and function.

NOTE It is not a requirement of this standard that conformity to the manufacturer’s specification of the resistor, current limiting device or fuse needs to be verified.

7.8.6 Protection against the polarity inversion and deep discharge of the cells

For level of protection “ma” and “mb” when more than 3 cells are used in series, the cell voltage shall be monitored. During discharging, if the voltage falls below the limit value for the cell voltage specified by the manufacturer of the cells or battery, the control device shall disconnect the cells or battery. For level of protection “mc”, if more than three cells are connected in series, precautions shall be taken to prevent reverse polarity charging of the cell.

NOTE 1 If several cells are connected in series, cells can change polarity during discharge due to the various capacities of the cells in a battery. These “reversed pole” cells can enter an inadmissible gassing range.

Where a deep discharge protection circuit is used to prevent reverse polarity charging of cells during discharge, the minimum cut-off voltage shall be that specified by the cell or battery manufacturer. After disconnecting the load, the current shall be no more than the discharge capacity at the 1 000 h rate.

NOTE 2 Such protection is often used to prevent cells going into a state of “deep discharge”. If an attempt is made to monitor too many cells connected in series, the protection will sometimes not function reliably due to tolerances in individual cell voltages and the protection circuit. Generally, monitoring of more than six cells (in series) by one protection unit is not effective.

7.8.7 Charging of cells or batteries

7.8.7.1 Level of protection “ma” and “mb”

The charging circuits shall be fully specified as part of the equipment. The charging system shall be such that either:

- a) with one fault condition of the charging system, the charging voltage and current shall not exceed the limits specified by the manufacturer;
- or
- b) if, during charging, it is possible for the limit values specified by the manufacturer of the cells or battery for the cell voltage or the charging current to be exceeded, a separate protective device in accordance with 7.9 shall be provided to minimize the possibility of a release of gas and also exceeding the manufacturer’s maximum rated cell temperature during charging.

7.8.7.2 Level of protection “mc”

The charging system shall be such that in normal operation the charge voltage and current do not exceed the limits specified by the manufacturer based on the specified temperature range of the equipment. If cells and batteries, which are an integral part of the electrical equipment are to be charged in the hazardous area, the charger shall be fully specified as part of the equipment design. If cells or batteries, which are an integral part of the electrical equipment or can be separated from the equipment are charged outside of the hazardous area, the charging shall be within the limits specified by the manufacturer of the equipment.

7.8.8 Requirements for control safety devices for cells or batteries

Where required, the control devices shall form safety related parts of a control system. It shall be the responsibility of the manufacturer to provide the information necessary to maintain the integrity of the system.

NOTE Safety related parts meeting the requirements of PL c of ISO 13849-1 “Safety of machinery – Safety related parts of control systems – Part 1: General principles for design” will satisfy this subclause.

7.9 Protective devices

7.9.1 General

If relying on a protective device to limit maximum surface temperature when the “m” equipment is subjected to a single fault for level of protection “mb” or two faults for level of protection “ma”, the protective device shall be provided either external to the equipment or directly integrated into the equipment. Protective devices for level of protection “ma” shall be non resettable. Thermal protective devices for level of protection “mb” may be resettable.

The protective device shall be capable of interrupting the maximum fault current of the circuit in which it is installed. The rated voltage of the protective device shall at least correspond to the working voltage of the circuit in which it is installed.

Where the “m” equipment contains a cell or battery and a control device is provided to prevent excessive overheating (see 7.8.5), this control device can also be considered as a protective device, providing it also protects all other components inside the same compound from exceeding the maximum surface temperature.

NOTE 1 The use of protective devices is to protect against faults and unforeseen overloads, which overheat and/or permanently damage or compromise the operational life of the equipment. Where resettable devices are used, the instructions include information to guide the user in the desirability of re-setting the devices. These instructions are considering external operational conditions under which they might be reset and also any subsequent monitoring that might be desirable.

NOTE 2 Both, self-resetting and manually resettable devices are considered to be resettable devices for the purpose of this standard.

For level of protection “ma”, if the non resettable protective device complies with the IEC 60127 series or IEC 60691 or ANSI/UL 248 series, only one device is necessary. This applies to 7.9.2 and 7.9.3.

NOTE 3 It is not a requirement of this standard that conformity to the manufacturer’s specification of the non resettable protective device needs to be verified.

NOTE 4 ANSI/UL 248-1 contains the applicable general safety requirements for low-voltage fuses, including the requirements to establish breaking capacity or interrupting rating. The other parts of the ANSI/UL 248 series provide additional specific safety requirements based on the intended application of the fuse, such as ANSI/UL 248-14 for supplemental low-voltage fuses.

7.9.2 Electrical protective devices

7.9.2.1 General

Protective devices shall have a voltage rating not less than that of the circuit in which they are installed and shall have a breaking capacity not less than the fault current of the circuit.

Unless otherwise specified, a fuse shall be assumed to be capable of passing 1,7 times the rated current continuously. The time-current characteristic of the fuse, as stated by the manufacturer of the fuse, shall ensure that the maximum surface temperature is not exceeded. For electrical protective devices two devices normally in series are required for level of protection "ma" and one device is required for level of protection "mb". If for level of protection "ma", the two devices are not in series, the activation of either device shall de-energize the circuitry relying on the protection. The two devices for level of protection "ma" shall be the same type of protective device (while not necessarily the same manufacturer and part number), so as to provide duplicated protection.

An electrical protective device is not required for level of protection "mc".

NOTE In the case of electrical supply networks where the rated voltage does not exceed 250 V, the prospective short-circuit fault current is usually 1 500 A.

7.9.2.2 Protective devices that are connected to the "m" equipment

If the protective device is external to the "m" equipment it shall be seen as equipment required for the safety of the "m" equipment, in accordance with 7.9.2. This specific condition of use shall appear on the certificate and the equipment shall be marked in accordance with the "specific conditions of use" marking requirements of IEC 60079-0.

The use of an external protective device and its connection to "m" equipment requires the device to be compatible with "ma", "mb", or "mc" as appropriate.

NOTE Failure to use such a device in the intended manner will lead to loss of level of protection. Where an external protective device is used to control the correct application of voltage, current and power to equipment with level of protection "ma", the performance of the external protective device or protective circuit is safe with one countable fault. The permitted levels of voltage, current and power are determined by the thermal characteristics of the "m" equipment.

7.9.3 Thermal protective devices

Thermal protective devices shall be used to protect the compound from damage caused by local heating, for example, by faulty components, or from exceeding the maximum surface temperature.

Non-resettable devices have no provision for being reset and open a circuit permanently after being exposed to a temperature higher than their operating temperature for a given maximum period. Adequate thermal coupling shall be achieved between the monitored component and the thermal protective device. The switching capability of the device shall be defined and shall be not less than the maximum possible load of the circuit.

If resettable thermal protective devices are used, two devices normally in series are required for level of protection "mb" and one device is required for level of protection "mc". If for level of protection "mb" the two resettable thermal protective devices are not in series, the activation of either device shall de-energize the circuitry relying on the protection. The two devices for level of protection "mb" shall be the same type of thermal protective device (while not necessarily the same manufacturer and part number), so as to provide duplicated protection.

Resettable thermal protective devices with switching contacts shall not be operated at more than 2/3 of their rated current specified by the manufacturer of the device.

Resettable thermal protective devices with switching contacts shall either comply with IEC 60730-2-9, or shall be tested according to 8.2.7.1.

Resettable thermal protective devices without switching contacts shall either comply with IEC 60738-1, or shall be tested according to 8.2.7.2.

NOTE 1 Often for functional reasons, additional resettable devices other than the thermal protective devices addressed by this clause are used. These devices typically operate at temperatures lower than the operating temperature of the thermal protective device.

NOTE 2 It is not a requirement of this standard that conformity to the manufacturer's specification of the resettable thermal protective device needs to be verified.

7.9.4 Built-in protective devices

Protective devices integral with the "m" equipment shall be of the enclosed type such that no compound can enter during the encapsulation process.

The suitability of the protective device for encapsulation shall be confirmed either by:

- a) a documentation from the manufacturer of the device;
- or
- b) testing of samples according 8.2.8.

NOTE Devices in glass, plastic, ceramic or otherwise sealed are regarded as enclosed types.

8 Type tests

8.1 Tests on the compound

8.1.1 Water absorption test

When required by 5.3.1 the test shall be carried out on samples of the compound(s) used in "m" equipment. Three dry samples of the compound(s) shall be tested. The samples shall be circular with a diameter of $50 \text{ mm} \pm 1 \text{ mm}$ and a thickness of $3 \text{ mm} \pm 0,2 \text{ mm}$. The samples shall be weighed then immersed for at least 24 h in water, at a temperature of $23 \text{ }^{\circ}\text{C} \begin{smallmatrix} +2 \\ 0 \end{smallmatrix} \text{ K}$. They shall then be taken out of the water, wiped dry and weighed again within 1 minute. The increase in mass shall not exceed 1 %.

It is not required to use distilled water for this test.

8.1.2 Dielectric strength test

The sample shall be circular with a diameter of $50 \text{ mm} \pm 1 \text{ mm}$ and a thickness of $3 \text{ mm} \pm 0,2 \text{ mm}$. The sample shall be symmetrically placed between electrodes $30 \text{ mm} \pm 1 \text{ mm}$ in diameter, within a temperature controlled oven, set to achieve the maximum service temperature of the compound.

A voltage of 4 kV r.m.s. $\begin{smallmatrix} +5 \\ 0 \end{smallmatrix} \%$ and with frequency between 48 Hz and 62 Hz shall be applied for not less than 5 min. No flashover or breakdown shall occur during the test.

8.2 Tests on the apparatus

8.2.1 Test sequence

The test sequence and number of samples are given in Annex B.

8.2.2 Maximum temperature

A sample of “m” equipment shall be subjected to a type test to ensure that:

- a) the temperature limits specified in 6.1 are not exceeded in normal operation;
- b) for level of protection “ma” and “mb” the maximum surface temperature is not exceeded under fault conditions as defined in 7.2.1.

For “m” equipment without an external load, the test shall be carried out in accordance with the temperature measurements of IEC 60079-0 taking into account the supply conditions given in 4.4.

For “m” equipment with an external load, the test shall be carried out for level of protection “ma” and “mb” by adjusting the current to the highest value, which does not cause the protective device to operate, and for level of protection “mc” at the specified load parameters in normal operation and in the case of regular expected occurrences.

For level of protection “ma” equipment, designed for EPL “Da” the maximum surface temperature shall be determined with the equipment mounted in accordance with the manufacturer’s instructions, and surrounded on all available surfaces by dust with a layer thickness of at least 200 mm. The final temperature shall be considered to have been reached when the rate of rise of temperature does not exceed 1 K/24 h.

NOTE Testing, simulation and analysis is sometimes used in order to achieve the required temperature limitations under malfunction conditions for equipment with characteristics such as non-linear external loads, input power control, or difficult to define failure modes

8.2.3 Thermal endurance test

8.2.3.1 Thermal endurance to heat

8.2.3.1.1 Level of protection “ma” and “mb”

The test shall be carried out in accordance with IEC 60079-0. The temperature to be used as the reference service temperature for the test shall be either:

- a) the maximum surface temperature of the test sample under normal operation plus 20 K;
or
- b) the maximum temperature at the component surface in the compound under normal operation, see 6.2.2.

8.2.3.1.2 Level of protection “mc”

The test shall be carried out in accordance with IEC 60079-0.

The temperature to be used as the reference service temperature for the test shall be the maximum surface temperature under normal operation, see 6.2.1.

8.2.3.2 Thermal endurance to cold

The test shall be carried out in accordance with IEC 60079-0.

8.2.3.3 Acceptance criteria

After each test the sample shall be subjected to a visual inspection. No visible damage to the compound that could impair the type of protection shall be evident, for example cracks in the compound, exposure of encapsulated parts, failure of adhesion, inadmissible shrinkage, discoloration, swelling, decomposition or softening. A discoloration on the surface of the compound is permissible (for example oxidation in the case of epoxy resin).

In addition, any electrical protective device on which safety depends, other than thermal fuses, shall be verified as remaining functional.

8.2.4 Dielectric strength test

8.2.4.1 Test procedure

The test shall be carried out on the following arrangements of circuits as applicable:

- a) between galvanically isolated circuits;
- b) between each circuit and all earthed parts;
- c) between each circuit and the surface of the compound or the non-metallic enclosure that, if necessary, can be clad with a conductive foil.

For arrangement a), the voltage U to be used shall be the sum of the rated voltages of the two circuits being tested and for arrangements b) and c), the voltage U to be used shall be the rated voltage of the circuit being tested.

For arrangement b), circuits that contain transient suppression components connected between the circuit and the earthed parts, a special test sample without these components shall be permitted for the type test.

Dielectric strength shall be verified by test:

- either as given in a relevant industrial standard for the individual items of electrical equipment or,
 - at the test voltage according to 1) or 2) below, and increased steadily within a period of not less than 10 s until it reaches the prescribed value, and it shall then be maintained for at least 60 s without dielectric breakdown occurring.
- 1) For equipment where the voltage U does not exceed 90 V peak, the test voltage shall be 500 V r.m.s. ($+5_0$ %) at 48 Hz to 62 Hz. Alternatively, the test voltage shall be 700 V d.c. ($+5_0$ %).
 - 2) For equipment where the voltage U exceeds 90 V peak, the test voltage shall be $2U + 1\ 000$ V r.m.s. ($+5_0$ %), with a minimum of 1 500 V r.m.s. at 48 Hz to 62 Hz. Alternatively, the test voltage shall be $2U + 1\ 400$ V d.c. ($+5_0$ %) with a minimum of 2 100 V d.c.

The test voltage shall be increased steadily within a period of not less than 10 s until it reaches the prescribed value, and it shall then be maintained for at least 60 s.

NOTE 1 In the case of equipment that, for electro-magnetic compatibility reasons, contain components connected to the enclosure for the suppression of interference pulses and which could be damaged during the tests, a partial discharge test is sometimes used as an alternative.

NOT 2 If the circuit under test is not accessible from the exterior it is possible to prepare a specific test sample with additional connections

8.2.4.2 Acceptance criteria

The test shall be deemed as passed if no breakdown or arcing occurs during testing.

NOTE Typically the current flowing during the test will not exceed 5 mA r.m.s..

8.2.5 Cable pull test

8.2.5.1 Test procedure

The test shall be carried out on one sample, previously unstressed and at $21\text{ °C} \pm 2\text{ °C}$.

A further test sample shall be subjected to the cable pull test after conditioning according to 8.2.3.1 at the maximum temperature at the cable entry point.

The tensile force (in Newton) applied shall either be 20 times the value in millimetres of the diameter of the cable or 5 times the mass (in kilograms) of the “m” equipment, whichever is the lower value. This value can be reduced to 25 % of the required value in the case of permanent installations. The minimum tensile force shall be 1 N and the minimum duration shall be 1 h. The force shall be applied in the least favourable direction.

8.2.5.2 Acceptance criteria

After testing, the sample shall be subjected to a visual inspection. Visible displacement of the cable, which affects the type of protection, shall not be evident. No damage to the compound or cable that could impair the type of protection shall be evident, for example, cracks in the compound, exposure of the encapsulated components or failure of adhesion.

8.2.6 Pressure test for Group I and Group II electrical equipment

8.2.6.1 Test procedure

For level of protection “ma” with any individual free spaces between 1 cm³ and 10 cm³ and level of protection “mb” with any individual free spaces between 10 cm³ and 100 cm³, two test samples shall be prepared with a pressure connection. Where there is more than one free space of a size requiring testing, the pressure test shall be carried out simultaneously in all those free spaces.

The pressure test shall be carried out on samples that have already been submitted to the thermal endurance tests (see 8.2.3).

The test shall be carried out with a pressure as shown in Table 6 applied for at least 10 s.

Table 6 – Test pressure

Minimum ambient temperature °C	Test pressure kPa
≥ -20 (a)	1 000
≥ -30	1 370
≥ -40	1 450
≥ -50	1 530
≥ -60	1 620
a) This covers equipment designed for the standard ambient temperature range specified in IEC 60079-0.	

As an alternative for ‘mb’ equipment if the component with a free space up to 100 cm³, prior to encapsulation, passes the Leakage test on sealed devices specified in IEC 60079-15 (without the conditioning, voltage, or dielectric withstand testing) it can be encapsulated without requiring the pressure test.

8.2.6.2 Acceptance criteria

After testing, the samples shall be visually inspected. No compound damage (such as cracks in the compound, exposure of the encapsulated components or failure of adhesion) that could impair the type of protection shall be evident. For constructions that are permitted to have no thickness of compound between a free space and a non-metallic enclosure wall, there shall also be no damage to the non-metallic enclosure wall(s)

8.2.7 Test for resettable thermal protective device

8.2.7.1 Resettable thermal protective devices with switching contacts

8.2.7.1.1 Test procedure

The function of the protective device shall be verified. This test shall be performed after the thermal endurance test. The device shall be capable switching its rated current $\geq 5\,000$ times.

8.2.7.1.2 Acceptance criteria

The test shall be deemed as passed if the protective device acts correctly after the test in the range specified in its datasheet.

8.2.7.2 Resettable thermal protective devices without switching contacts

8.2.7.2.1 Test procedure

The function of the protective device shall be verified. This test shall be performed after the thermal endurance test. The device shall be capable of acting (direct or indirect limiting the temperature rise) ≥ 500 times.

8.2.7.2.2 Acceptance criteria

The test shall be deemed as passed if the protective device acts correctly after the test in the range specified in its datasheet.

8.2.8 Sealing test for built-in protective devices

The test is to be performed on five samples. With the test samples at an initial temperature of (25 ± 2) °C, they are suddenly immersed in water at a temperature of (50 ± 2) °C to a depth of not less than 25 mm for at least 1 min. The devices are considered to be satisfactory if no bubbles emerge from the samples during this test. Alternatively, a test can be applied where five samples are examined after the encapsulation to ensure that the compound has not entered the interior.

9 Routine verifications and tests

9.1 Visual inspections

Each piece of “m” equipment shall be subjected to a visual inspection. No damage shall be evident, such as cracks in the compound, exposure of the encapsulated parts, flaking, inadmissible shrinkage, swelling, decomposition, failure of adhesion (separation of any adhered parts) or softening.

9.2 Dielectric strength test

For circuits, which are accessible from the exterior the dielectric strength test shall be used to test the isolation of circuits from each other and from their environment. The test shall be carried out on these circuits in accordance with 8.2.4.

The test voltage shall be applied for at least 1 s.

Alternatively, 1,2 times the test voltage may be applied and maintained for at least 100 ms.

In some cases, the actual test period may need to be significantly longer than 100 ms as a sample with a large distributed capacitance takes some additional time to reach the required test voltage.

The test shall be deemed as passed if no breakdown or arcing occurs during testing.

NOTE Typically the current flowing during the test will not exceed 5 mA r.m.s..

Contrary to the above, the dielectric strength test for cells or batteries shall be carried out in accordance with the routine dielectric test requirements of IEC 60079-7.

In the case of equipment that employs circuits that contain transient suppression components connected between the circuit and the earthed parts, the equipment need not be subjected to routine dielectric strength tests, if intended for use only with a galvanically isolated circuit, and shall be marked “X” to indicate this specific condition of use in accordance with the “specific conditions of use” marking requirements of IEC 60079-0.

For level of protection “mc”, where there is a routine dielectric strength test in the relevant industrial standard for the individual items of the electrical equipment, this test shall be permitted to be used to satisfy the routine dielectric test requirement for level of protection “mc”.

10 Marking

In addition to the requirements of IEC 60079-0, the marking shall include:

- a) the rated voltage,
- b) the rated current,
- c) the prospective short-circuit current of the external electric supply source if less than 1 500 A, for example “Permitted supply short-circuit current: 500 A”.
- d) optionally, the permitted prospective short-circuit current of the external electrical supply if the equipment is designed for a short-circuit current of 1 500 A or more, for example “Permitted supply short-circuit current: 3 500 A”.
- e) for levels of protection “mb” and “mc” for EPL Db and EPL Dc, tested without a dust layer, the maximum surface temperature in degrees Celsius and the unit of measurement °C preceded with the letter “T”, (e.g. T 90 °C). For level of protection “ma” for EPL Da, and where appropriate for level of protection “mb” and “mc” for EPL Db and EPL Dc tested with dust layer, the maximum surface temperature T_L shall be shown as a temperature value in degrees Celsius and the unit of measurement °C, with the layer depth L indicated as a subscript in mm, (e.g. $T_{200} 320$ °C). In the case of Levels of Protection “mb” and “mc” for EPL Db or Dc, tested with a dust layer, The maximum surface temperature without the dust layer is not required to be marked. Alternatively the marking indicated in c), d) and e) above can be included in the instructions and the equipment shall be marked “X” to indicate this specific condition of use in accordance with the “specific conditions of use” marking requirements of IEC 60079-0.

Annex A
(informative)

Basic requirements for compounds for “m” equipment

Figure A.1 shows basic requirements for compounds for "m" equipment.

NOTE This Annex only provides a general overview. Specific attention needs to be paid to the detailed text of the applicable requirements when developing the test program for specific equipment.

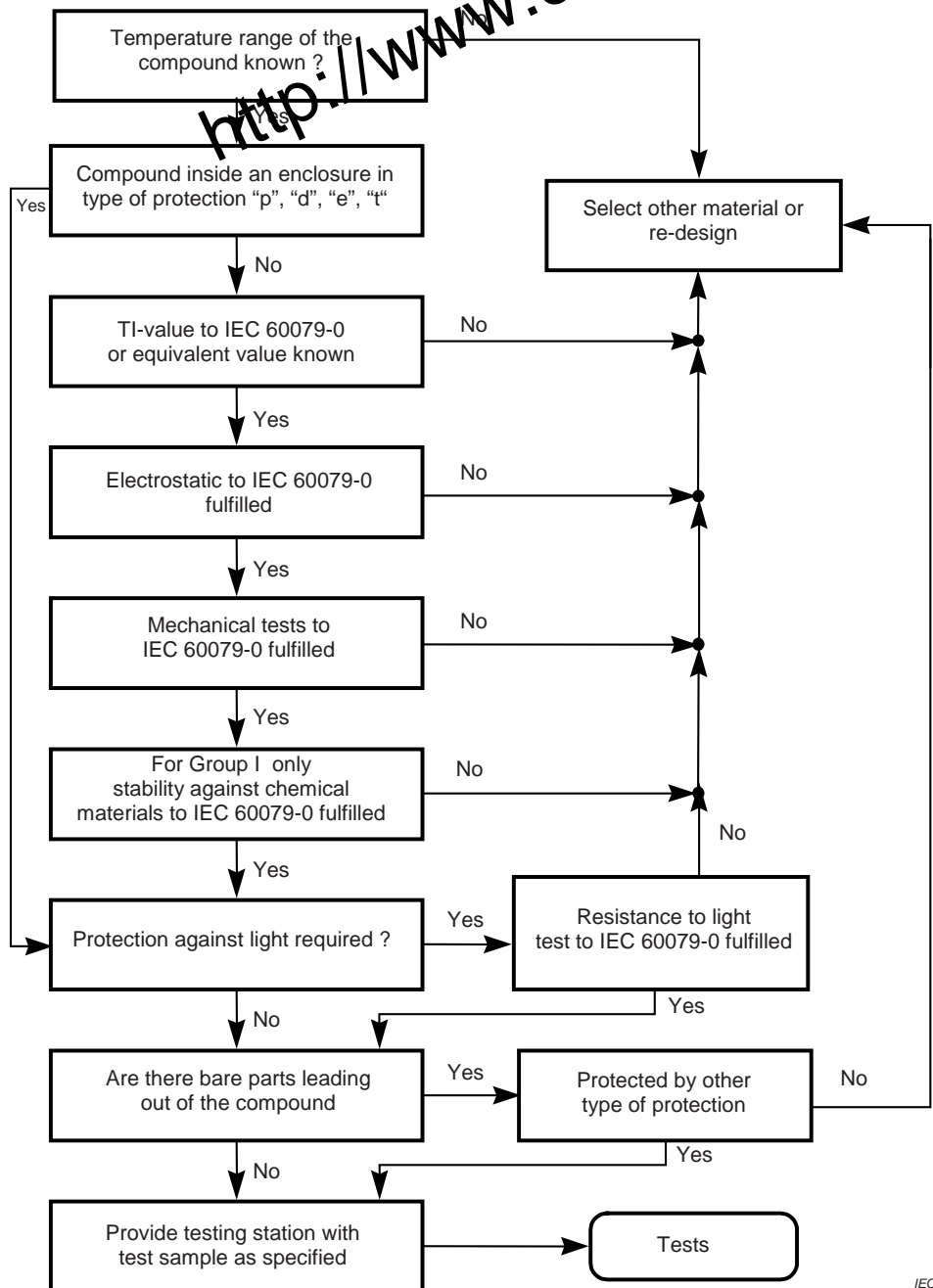

Figure A.1 – Basic requirements for compounds for “m” equipment

Annex B
(informative)

Allocation of test samples

Table B.1 shows allocation of test samples.

NOTE This Annex only provides a general overview. Specific attention needs to be paid to the detailed text of the applicable requirements when developing the test program for specific equipment.

Table B.1 – Allocation of test samples

Standard tests		Additional tests	
Sample 1	Sample 2	Sample 3	Sample 4
Determination of limiting temperature in accordance with 6.3			
		Cable pull test in accordance with 8.2.5	Thermal endurance test based on the service temperature determined at the point where the cable enters the compound in accordance with 8.2.3.1
Thermal endurance to heat in accordance with 8.2.3.1	Thermal endurance to heat in accordance with 8.2.3.1		
Thermal endurance to cold in accordance with 8.2.3.2	Thermal endurance to cold in accordance with 8.2.3.2		
Resettable thermal protective device test in accordance with 8.2.7	Resettable thermal protective device test in accordance with 8.2.7		Cable pull test in accordance with 8.2.5
Dielectric strength test in accordance with 8.2.4	Dielectric strength test in accordance with 8.2.4		
Pressure test in accordance with 8.2.6 (if required)	Pressure test in accordance with 8.2.6 (if required)		
Mechanical tests in accordance with IEC 60079-0 (if required)	Mechanical tests in accordance with IEC 60079-0 (if required)		
The tests are carried out in the order they appear in each column.			

Bibliography

- IEC 60050-426, *International Electrotechnical Vocabulary – Part 426: Equipment for explosive atmospheres*
- IEC 60079-1, *Explosive atmospheres – Part 1: Equipment protection by flameproof enclosures "d"*
- IEC 60079-2, *Explosive atmospheres – Part 2: Equipment protection by pressurized enclosures "p"*
- IEC 60079-5, *Explosive atmospheres – Part 5: Equipment protection by powder filling "q"*
- IEC 60079-6, *Explosive atmospheres – Part 6: Equipment protection by oil immersion "o"*
- IEC 60079-10-1, *Explosive atmospheres – Part 10-1: Classification of areas – Explosive gas atmospheres*
- IEC 60079-10-2, *Explosive atmospheres – Part 10-2: Classification of areas – Combustible dust atmospheres*
- IEC 60079-14, *Explosive atmospheres – Part 14: Electrical installations design, selection and erection*
- IEC 60079-28, *Explosive atmospheres – Part 28: Protection of equipment and transmission systems using optical radiation*
- IEC 60086-1, *Primary batteries – Part 1: General*
- IEC 60622, *Secondary cells and batteries containing alkaline or other non-acid electrolytes – Sealed nickel-cadmium prismatic rechargeable single cells*
- IEC 60664-1, *Insulation coordination for equipment within low-voltage systems – Part 1: Principles, requirements and tests*
- IEC 60747-5-5, *Semiconductor devices – Discrete devices – Part 5-5: Optoelectronic devices – Photocouplers*
- IEC 61951-1, *Secondary cells and batteries containing alkaline or other non-acid electrolytes – Portable sealed rechargeable single cells – Part 1: Nickel-cadmium*
- IEC 61951-2, *Secondary cells and batteries containing alkaline or other non-acid electrolytes – Portable sealed rechargeable single cells – Part 2: Nickel-metal hydride*
- ISO 13849-1, *Safety of machinery – Safety-related parts of control systems – Part 1: General principles for design*
-

<http://www.china-gauges.com/>

British Standards Institution (BSI)

BSI is the national body responsible for preparing British Standards and other standards-related publications, information and services.

BSI is incorporated by Royal Charter. British Standards and other standardization products are published by BSI Standards Limited.

About us

We bring together business, industry, government, consumers, innovators and others to shape their combined experience and expertise into standards-based solutions.

The knowledge embodied in our standards has been carefully assembled in a dependable format and refined through our open consultation process. Organizations of all sizes and across all sectors choose standards to help them achieve their goals.

Information on standards

We can provide you with the knowledge that your organization needs to succeed. Find out more about British Standards by visiting our website at bsigroup.com/standards or contacting our Customer Services team or Knowledge Centre.

Buying standards

You can buy and download PDF versions of BSI publications, including British and adopted European and international standards, through our website at bsigroup.com/shop, where hard copies can also be purchased.

If you need international and foreign standards from other Standards Development Organizations, hard copies can be ordered from our Customer Services team.

Subscriptions

Our range of subscription services are designed to make using standards easier for you. For further information on our subscription products go to bsigroup.com/subscriptions.

With **British Standards Online (BSOL)** you'll have instant access to over 55,000 British and adopted European and international standards from your desktop. It's available 24/7 and is refreshed daily so you'll always be up to date.

You can keep in touch with standards developments and receive substantial discounts on the purchase price of standards, both in single copy and subscription format, by becoming a **BSI Subscribing Member**.

PLUS is an updating service exclusive to BSI Subscribing Members. You will automatically receive the latest hard copy of your standards when they're revised or replaced.

To find out more about becoming a BSI Subscribing Member and the benefits of membership, please visit bsigroup.com/shop.

With a **Multi-User Network Licence (MUNL)** you are able to host standards publications on your intranet. Licences can cover as few or as many users as you wish. With updates supplied as soon as they're available, you can be sure your documentation is current. For further information, email bsmusales@bsigroup.com.

BSI Group Headquarters

389 Chiswick High Road London W4 4AL UK

Revisions

Our British Standards and other publications are updated by amendment or revision.

We continually improve the quality of our products and services to benefit your business. If you find an inaccuracy or ambiguity within a British Standard or other BSI publication please inform the Knowledge Centre.

Copyright

All the data, software and documentation set out in all British Standards and other BSI publications are the property of and copyrighted by BSI, or some person or entity that owns copyright in the information used (such as the international standardization bodies) and has formally licensed such information to BSI for commercial publication and use. Except as permitted under the Copyright, Designs and Patents Act 1988 no extract may be reproduced, stored in a retrieval system or transmitted in any form or by any means – electronic, photocopying, recording or otherwise – without prior written permission from BSI. Details and advice can be obtained from the Copyright & Licensing Department.

Useful Contacts:

Customer Services

Tel: +44 845 086 9001

Email (orders): orders@bsigroup.com

Email (enquiries): cservices@bsigroup.com

Subscriptions

Tel: +44 845 086 9001

Email: subscriptions@bsigroup.com

Knowledge Centre

Tel: +44 20 8996 7004

Email: knowledgecentre@bsigroup.com

Copyright & Licensing

Tel: +44 20 8996 7070

Email: copyright@bsigroup.com