

BS EN 60079-32-2:2015



BSI Standards Publication

Explosive atmospheres

Part 32-2: Electrostatics hazards — Tests

bsi.

...making excellence a habit.™

National foreword

This British Standard is the UK implementation of EN 60079-32-2:2015. It is identical to IEC 60079-32-2:2015.

The UK participation in its preparation was entrusted to Technical Committee EXL/31, Equipment for explosive atmospheres.

A list of organizations represented on this committee can be obtained on request to its secretary.

This publication does not purport to include all the necessary provisions of a contract. Users are responsible for its correct application.

© The British Standards Institution 2015.

Published by BSI Standards Limited 2015

ISBN 978 0 580 81609 3

BSI 20150520

Compliance with a British Standard cannot confer immunity from legal obligations.

This British Standard was published under the authority of the Standards Policy and Strategy Committee on 31 May 2015.

Amendments/corrigenda issued since publication

| Date | Text affected |
|------|---------------|
|------|---------------|

EUROPEAN STANDARD

EN 60079-32-2

NORME EUROPÉENNE

EUROPÄISCHE NORM

April 2015

ICS 29.260.20

English Version

Explosive atmospheres - Part 32-2: Electrostatics hazards -
Tests

(IEC 60079-32-2:2015)

Atmosphères explosives - Partie 32-2: Dangers
électrostatiques - Essais
(IEC 60079-32-2:2015)Explosionsgefährdete Bereiche - Teil 32-2: Elektrostatische
Gefährdungen - Prüfverfahren
(IEC 60079-32-2:2015)

This European Standard was approved by CENELEC on 2015-04-01. CENELEC members are bound to comply with the CEN/CENELEC Internal Regulations which stipulate the conditions for giving this European Standard the status of a national standard without any alteration.

Up-to-date lists and bibliographical references concerning such national standards may be obtained on application to the CEN-CENELEC Management Centre or to any CENELEC member.

This European Standard exists in three official versions (English, French, German). A version in any other language made by translation under the responsibility of a CENELEC member into its own language and notified to the CEN-CENELEC Management Centre has the same status as the official versions.

CENELEC members are the national electrotechnical committees of Austria, Belgium, Bulgaria, Croatia, Cyprus, the Czech Republic, Denmark, Estonia, Finland, Former Yugoslav Republic of Macedonia, France, Germany, Greece, Hungary, Iceland, Ireland, Italy, Latvia, Lithuania, Luxembourg, Malta, the Netherlands, Norway, Poland, Portugal, Romania, Slovakia, Slovenia, Spain, Sweden, Switzerland, Turkey and the United Kingdom.



European Committee for Electrotechnical Standardization
Comité Européen de Normalisation Electrotechnique
Europäisches Komitee für Elektrotechnische Normung

CEN-CENELEC Management Centre: Avenue Marnix 17, B-1000 Brussels

Foreword

The text of document 31/1164/FDIS, future edition 1 of IEC 60079-32-2, prepared by IEC/TC 31 "Equipment for explosive atmospheres" was submitted to the IEC-CENELEC parallel vote and approved by CENELEC as EN 60079-32-2:2015.

The following dates are fixed:

- latest date by which the document has to be implemented at national level by publication of an identical national standard or by endorsement (dop) 2016-01-01
- latest date by which the national standards conflicting with the document have to be withdrawn (dow) 2018-04-01

Attention is drawn to the possibility that some of the elements of this document may be the subject of patent rights. CENELEC [and/or CEN] shall not be held responsible for identifying any or all such patent rights.

Endorsement notice

The text of the International Standard IEC 60079-32-2:2015 was approved by CENELEC as a European Standard without any modification.

| | | |
|----------------|------|------------------------------|
| IEC 60079-1 | NOTE | Harmonized as EN 60079-1. |
| IEC 60079-7 | NOTE | Harmonized as EN 60079-7. |
| IEC 60079-10-1 | NOTE | Harmonized as EN 60079-10-1. |
| IEC 60079-10-2 | NOTE | Harmonized as EN 60079-10-2. |
| IEC 60167 | NOTE | Harmonized as HD 568 S1. |
| IEC 61340-4-1 | NOTE | Harmonized as EN 61340-4-1. |
| IEC 61340-4-3 | NOTE | Harmonized as EN 61340-4-3. |
| IEC 61340-4-5 | NOTE | Harmonized as EN 61340-4-5. |
| ISO 284 | NOTE | Harmonized as EN ISO 284. |
| ISO 8031 | NOTE | Harmonized as EN ISO 8031. |
| ISO 8330 | NOTE | Harmonized as EN ISO 8330. |

Annex ZA (normative)

Normative references to international publications with their corresponding European publications

The following documents, in whole or in part, are normatively referenced in this document and are indispensable for its application. For dated references, only the edition cited applies. For undated references, the latest edition of the referenced document (including any amendments) applies.

NOTE 1 When an International Publication has been modified by common modifications, indicated by (mod), the relevant EN/HD applies.

NOTE 2 Up-to-date information on the latest versions of the European Standards listed in this annex is available here: www.cenelec.eu.

| <u>Publication</u> | <u>Year</u> | <u>Title</u> | <u>EN/HD</u> | <u>Year</u> |
|--------------------|-------------|--|-------------------|-------------|
| IEC 60079-0 | - | Explosive atmospheres -- Part 0: Equipment - General requirements | EN 60079-0 | - |
| - | - | | +A11 | - |
| IEC 60093 | - | Methods of test for volume resistivity and surface resistivity of solid electrical insulating materials | HD 429 S1 | - |
| IEC 60243-1 | - | Electric strength of insulating materials - Test methods -- Part 1: Tests at power frequencies | EN 60243-1 | - |
| IEC 60243-2 | - | Electric strength of insulating materials - Test methods -- Part 2: Additional requirements for tests using direct voltage | EN 60243-2 | - |
| IEC 60247 | - | Insulating liquids - Measurement of relative permittivity, dielectric dissipation factor (tan δ) and d.c. resistivity | EN 60247 | - |
| IEC 61340-2-1 | - | Electrostatics -- Part 2-1: Measurement methods - Ability of materials and products to dissipate static electric charge | EN 61340-2-1 | - |
| IEC 61340-2-3 | - | Electrostatics -- Part 2-3: Methods of test for determining the resistance and resistivity of solid planar materials used to avoid electrostatic charge accumulation | EN 61340-2-3 | - |
| IEC 61340-4-4 | - | Electrostatics - Part 4-4: Standard test methods for specific applications - Electrostatic classification of flexible intermediate bulk containers (FIBC) | EN 61340-4-4 | - |
| ISO 14309 | - | Rubber, vulcanized or thermoplastic - Determination of volume and/or surface resistivity | - | - |
| IEC/TS 60079-32-1 | - | Explosive atmospheres - Part 32-1: Electrostatic hazards, guidance | CLC/TR 60079-32-1 | - |
| IEC/TS 61241-2-2 | - | Electrical apparatus for use in the presence of combustible dust -- Part 2: Test methods -- Section 2: Method for determining the electrical resistivity of dust in layers | EN 61241-2-2 | - |
| ASTM E582 | - | Standard test method for minimum ignition energy and quenching distance in gaseous mixtures | - | - |
| EN 1081 | - | Resilient floor coverings - Determination of the electrical resistance | - | - |
| EN 1149-3 | - | Protective clothing - Electrostatic properties - Part 3: Test methods for measurement of charge decay | - | - |

CONTENTS

| | |
|-------------------------------------|----|
| FOREWORD..... | 7 |
| 1 Scope..... | 7 |
| 2 Normative references | 7 |
| 3 Terms and definitions | 8 |
| 4 Test methods..... | 10 |
| 4.1 General..... | 10 |
| 4.2 Surface resistance | 11 |
| 4.2.1 General | 11 |
| 4.2.2 Principle | 12 |
| 4.2.3 Apparatus..... | 12 |
| 4.2.4 Test sample..... | 13 |
| 4.2.5 Procedure..... | 13 |
| 4.2.6 Acceptance criteria | 14 |
| 4.2.7 Test report..... | 14 |
| 4.3 Surface resistivity | 14 |
| 4.4 Volume resistivity..... | 14 |
| 4.5 Leakage resistance..... | 15 |
| 4.5.1 General | 15 |
| 4.5.2 Principle | 15 |
| 4.5.3 Apparatus..... | 15 |
| 4.5.4 Test sample..... | 15 |
| 4.5.5 Procedure..... | 16 |
| 4.5.6 Acceptance criteria | 16 |
| 4.5.7 Test report..... | 16 |
| 4.6 In-use testing of footwear..... | 16 |
| 4.6.1 General | 16 |
| 4.6.2 Principle | 16 |
| 4.6.3 Apparatus..... | 17 |
| 4.6.4 Procedure..... | 17 |
| 4.6.5 Acceptance criteria | 17 |
| 4.6.6 Test report..... | 17 |
| 4.7 In-use testing of gloves..... | 17 |
| 4.7.1 General | 17 |
| 4.7.2 Principle | 18 |
| 4.7.3 Apparatus..... | 18 |
| 4.7.4 Procedure..... | 18 |
| 4.7.5 Acceptance criteria | 18 |
| 4.7.6 Test report..... | 18 |
| 4.8 Powder resistivity..... | 18 |
| 4.8.1 General | 18 |
| 4.8.2 Principle | 19 |
| 4.8.3 Apparatus..... | 19 |
| 4.8.4 Procedure..... | 20 |
| 4.8.5 Acceptance criteria | 20 |
| 4.8.6 Test report..... | 20 |
| 4.9 Liquid conductivity | 21 |

| | | |
|--------|-------------------------------------|----|
| 4.9.1 | General | 21 |
| 4.9.2 | Principle | 21 |
| 4.9.3 | Apparatus | 21 |
| 4.9.4 | Procedure | 22 |
| 4.9.5 | Acceptance criteria | 23 |
| 4.9.6 | Test report | 23 |
| 4.10 | Capacitance | 23 |
| 4.10.1 | General | 23 |
| 4.10.2 | Principle | 24 |
| 4.10.3 | Apparatus | 24 |
| 4.10.4 | Test sample | 24 |
| 4.10.5 | Procedure for moveable items | 24 |
| 4.10.6 | Procedure for installed items | 25 |
| 4.10.7 | Acceptance criteria | 25 |
| 4.10.8 | Test report | 25 |
| 4.11 | Transferred charge | 25 |
| 4.11.1 | General | 25 |
| 4.11.2 | Principle | 26 |
| 4.11.3 | Apparatus | 26 |
| 4.11.4 | Test sample | 27 |
| 4.11.5 | Procedure | 27 |
| 4.11.6 | Acceptance criteria | 28 |
| 4.11.7 | Test report | 28 |
| 4.12 | Ignition test | 29 |
| 4.12.1 | General | 29 |
| 4.12.2 | Apparatus | 29 |
| 4.12.3 | Procedure | 32 |
| 4.12.4 | Acceptance criteria | 32 |
| 4.12.5 | Test report | 32 |
| 4.13 | Measuring of charge decay | 33 |
| 4.13.1 | General | 33 |
| 4.13.2 | Principle | 33 |
| 4.13.3 | Apparatus | 33 |
| 4.13.4 | Test sample | 34 |
| 4.13.5 | Procedure | 34 |
| 4.13.6 | Acceptance criteria | 35 |
| 4.13.7 | Test report | 35 |
| 4.14 | Breakdown voltage | 35 |
| 4.14.1 | General | 35 |
| 4.14.2 | Principle | 35 |
| 4.14.3 | Apparatus | 35 |
| 4.14.4 | Test procedure | 36 |
| 4.14.5 | Acceptance criteria | 37 |
| 4.14.6 | Test report | 37 |
| | Bibliography | 38 |

Figure 1 – Test sample with applied electrodes (dimensions in mm) 12

Figure 2 – Measuring cell for powder resistivity 19

Figure 3 – Measuring cell for liquid conductivity 22

Figure 4 – Ignition probe 31

Figure 5 – Perforated plate of ignition probe 32

Figure 6 – Example of an arrangement for measurement of charge decay 34

Figure 7 – Electrodes for measuring breakdown voltage of sheets 36

Table 1 – Volume concentrations of flammable test gas mixtures 30

<http://www.china-gauges.com/>

INTERNATIONAL ELECTROTECHNICAL COMMISSION

EXPLOSIVE ATMOSPHERES –

Part 32-2: Electrostatics hazards – Tests

FOREWORD

- 1) The International Electrotechnical Commission (IEC) is a worldwide organization for standardization comprising all national electrotechnical committees (IEC National Committees). The object of IEC is to promote international co-operation on all questions concerning standardization in the electrical and electronic fields. To this end and in addition to other activities, IEC publishes International Standards, Technical Specifications, Technical Reports, Publications, Available Specifications (PAS) and Guides (hereafter referred to as "IEC Publication(s)"). Their preparation is entrusted to technical committees; any IEC National Committee interested in the subject dealt with may participate in this preparatory work. International, governmental and non-governmental organizations liaising with the IEC also participate in this preparation. IEC collaborates closely with the International Organization for Standardization (ISO) in accordance with conditions determined by agreement between the two organizations.
- 2) The formal decisions or agreements of IEC on technical matters express, as nearly as possible, an international consensus of opinion on the relevant subjects since each technical committee has representation from all interested IEC National Committees.
- 3) IEC Publications have the form of recommendations for international use and are accepted by IEC National Committees in that sense. While all reasonable efforts are made to ensure that the technical content of IEC Publications is accurate, IEC cannot be held responsible for the way in which they are used or for any misinterpretation by any end user.
- 4) In order to promote international uniformity, IEC National Committees undertake to apply IEC Publications transparently to the maximum extent possible in their national and regional publications. Any divergence between any IEC Publication and the corresponding national or regional publication shall be clearly indicated in the latter.
- 5) IEC itself does not provide any attestation of conformity. Independent certification bodies provide conformity assessment services and, in some areas, access to IEC marks of conformity. IEC is not responsible for any services carried out by independent certification bodies.
- 6) All users should ensure that they have the latest edition of this publication.
- 7) No liability shall attach to IEC or its directors, employees, servants or agents including individual experts and members of its technical committees and IEC National Committees for any personal injury, property damage or other damage of any nature whatsoever, whether direct or indirect, or for costs (including legal fees) and expenses arising out of the publication, use of, or reliance upon, this IEC Publication or any other IEC Publications.
- 8) Attention is drawn to the Normative references cited in this publication. Use of the referenced publications is indispensable for the correct application of this publication.
- 9) Attention is drawn to the possibility that some of the elements of this IEC Publication may be the subject of patent rights. IEC shall not be held responsible for identifying any or all such patent rights.

International Standard IEC 60079-32-2 has been prepared by IEC technical committee 31: Equipment for explosive atmospheres.

The text of this standard is based on the following documents:

| FDIS | Report on voting |
|--------------|------------------|
| 31/1164/FDIS | 31/1176/RVD |

Full information on the voting for the approval of this standard can be found in the report on voting indicated in the above table.

This publication has been drafted in accordance with the ISO/IEC Directives, Part 2.

A list of all parts of the IEC 60079 series, under the general title *Explosive atmospheres*, can be found on the IEC website.

The committee has decided that the contents of this publication will remain unchanged until the stability date indicated on the IEC web site under "http://webstore.iec.ch" in the data related to the specific publication. At this date, the publication will be

- reconfirmed,
- withdrawn,
- replaced by a revised edition, or
- amended.

<http://www.china-gauges.com/>

EXPLOSIVE ATMOSPHERES –

Part 32-2: Electrostatics hazards – Tests

1 Scope

This part of IEC 60079 describes test methods concerning the equipment, product and process properties necessary to avoid ignition and electrostatic shock hazards arising from static electricity. It is intended for use in a risk assessment of electrostatic hazards or for the preparation of product family or detailed product standards for electrical or non-electrical machines or equipment.

The purpose of this part of IEC 60079 is to provide standard test methods used for the control of static electricity, such as surface resistance, earth leakage resistance, powder resistivity, liquid conductivity, capacitance and evaluation of the incendivity of provoked discharges. It is especially intended for use with existing standards of the IEC 60079 series.

NOTE IEC TS 60079-32-1, *Explosive atmospheres – Part 32-1: Electrostatic hazards, guidance*, was published in 2013. This international standard is not intended to supersede standards that cover specific products and industrial situations.

This part of IEC 60079 presents the latest state of knowledge which may, however, slightly differ from requirements in other standards, especially concerning test climates. When a requirement of this standard conflicts with a requirement specified in IEC 60079-0, to avoid the possibility of re-testing previously approved equipment, the requirement in IEC 60079-0 applies only for equipment within the scope of IEC 60079-0. In all other cases, the statements in this part of IEC 60079 apply.

2 Normative references

The following documents, in whole or in part, are normatively referenced in this document and are indispensable for its application. For dated references, only the edition cited applies. For undated references, the latest edition of the referenced document (including any amendments) applies.

IEC 60079-0, *Explosive atmospheres – Part 0: Equipment – General requirements*

IEC TS 60079-32-1, *Explosive atmospheres – Part 32-1: Electrostatic hazards, guidance*

IEC 60093, *Methods of test for volume resistivity and surface resistivity of solid electrical insulating materials*

IEC 60243-1, *Electric strength of insulating materials – Test methods – Part 1: Tests at power frequencies*

IEC 60243-2, *Electric strength of insulating materials – Test methods – Part 2: Additional requirements for tests using direct voltage*

IEC 60247, *Insulating liquids – Measurement of relative permittivity, dielectric dissipation factor ($\tan \delta$) and d.c. resistivity*

IEC TS 61241-2-2, *Electrical apparatus for use in the presence of combustible dust – Part 2: Test methods – Section 2: Method for determining the electrical resistivity of dust in layers*

IEC 61340-2-1, *Electrostatics – Part 2-1: Measurement methods – Ability of materials and products to dissipate static electric charge*

IEC 61340-2-3, *Electrostatics – Part 2-3: Methods of test for determining the resistance and resistivity of solid planar materials used to avoid electrostatic charge accumulation*

IEC 61340-4-4, *Electrostatics – Part 4-4: Standard test methods for specific applications – Electrostatic classification of flexible intermediate bulk containers (FIBCs)*

ISO 14309, *Rubber, vulcanized or thermoplastic – Determination of volume and/or surface resistivity*

ASTM E582, *Standard test method for minimum ignition energy and quenching distance in gaseous mixtures*

EN 1081, *Resilient floor coverings – Determination of the electrical resistance*

EN 1149-3, *Protective clothing – Electrostatic properties Part 3: Test methods for measurement of charge decay.*

3 Terms and definitions

For the purposes of this document, the following terms and definitions apply.

3.1 conductive

having a resistivity or resistance below the dissipative range (see 3.4) allowing stray current arcs and electric shocks to occur

Note 1 to entry: Conductive materials or objects are neither dissipative nor insulating and are incapable of retaining a significant electrostatic charge when in contact with earth.

Note 2 to entry: Boundary limits are given in IEC TS 60079-32-1 for the conductive range for solid materials, enclosures, some objects and bulk materials.

Note 3 to entry: Product standards and other standards covering electrostatic properties often include specific definitions of “conductive” which apply only to items covered by those standards and may be different from the definitions given here. See e.g. ISO 8031 and ISO 8330 for hose assemblies, ISO 284 for belts and EN 1149-1, -2, -3 and -5 for protective clothing.

3.2 conductivity (electrical conductivity)

reciprocal of volume resistivity, expressed in siemens per metre (see 3.14)

3.3 conductor

conductive object

3.4 dissipative (electrostatic dissipative)

having an intermediate resistivity or resistance that lies between the conductive and insulating ranges (see 3.1 and 3.7)

Note 1 to entry: Dissipative materials or objects are neither conductive nor insulating but, like conductive items, safely limit contact charging and/or dissipate even the maximum charging currents associated with their designed application when in contact with earth

Note 2 to entry: Boundary limits are given in IEC TS 60079-32-1 for the dissipative range for solid materials, enclosures, some objects and bulk materials.

Note 3 to entry: Product standards often include specific definitions of “dissipative” which apply only to items covered by those standards and may be different to the definitions given here. See 3.1, Note 3 to entry.

3.5 enclosure

walls, doors, covers, cable glands, rods, spindles, shafts, coatings, etc. which surround and enclose equipment

Note 1 to entry: For electrical equipment, the enclosure is likely to be identical to the enclosure defined in IEC 60079-0.

Note 2 to entry: Flexible Intermediate Bulk Containers (FIBC) and other similar containers are not equipment enclosures and, therefore, are considered separately in IEC TS 60079-32-1.

3.6 hazardous area

area in which flammable or explosive gas/vapour-air or dust-air mixtures are, or can be, present in such quantities as to require special precautions against ignition

Note 1 to entry: See IEC 60079-10-1 and IEC 60079-10-2.

3.7 insulating

having a resistivity or resistance that is higher than the dissipative range (see 3.4)

Note 1 to entry: Insulating materials or objects are neither conductive nor dissipative. Electrostatic charges can accumulate on them and do not readily dissipate even when they are in contact with earth.

Note 2 to entry: Boundary limits are given in IEC TS 60079-32-1 for the insulating range for solid materials, enclosures, some objects and bulk materials. For certain items, special definitions are maintained in other standards.

Note 3 to entry: Product standards and other standards covering electrostatic properties often include specific definitions of “insulating” which apply only to items covered by those standards and may be different to the definitions given here. See 3.1, Note 3 to entry.

Note 4 to entry: The adjective “non-conductive” has often been used as a synonym for insulating. It is avoided in this document as it could be taken to mean either “insulating” or “insulating or dissipative” and this may lead to confusion.

3.8 isolated conductor

conductive object which can accumulate charge due to an earth leakage resistance exceeding the values given in IEC TS 60079-32-1

3.9 leakage resistance (resistance to earth)

resistance expressed in ohms between an electrode in contact with the surface to be measured and earth

Note 1 to entry: The leakage resistance depends upon the volume and/or surface resistivity of the materials and the distance between the chosen point of measurement and earth.

3.10 resistance

quotient of voltage and current flowing through a sample

Note 1 to entry: Depending on the electrodes applied the following resistances are distinguished:

Insulation resistance (ohms), see 3.11

Leakage resistance (ohms), see 3.9

Surface resistance (ohms), see 3.11

Surface resistivity (ohms), see 3.12

It may be difficult to understand that the occurring statistical scatter cannot be minimized by improving the quality of the tests. Nevertheless, one has to accept this situation, remembering that electrostatic tests contain adequate safety margins just to compensate for this effect.

Fabrication processes (e.g. moulding, extrusion, etc.) can change the electrostatic properties of materials. It is, therefore, recommended to test finished products, where possible, rather than the materials from which the products are made.

To obtain comparable results all over the world for laboratory measurements, the samples should be acclimated and measured at the stated relative humidity and temperature (mostly for at least 24 h at $(23 \pm 2) ^\circ\text{C}$ and $(25 \pm 5) \%$ relative humidity). In countries which may experience lower or higher humidity and temperature levels, an additional value at the local higher or lower relative humidity and temperature may be reasonable (e.g. $(40 \pm 2) ^\circ\text{C}$ and $(90 \pm 5) \%$ relative humidity for tropical climates and $(23 \pm 2) ^\circ\text{C}$ and $(15 \pm 5) \%$ relative humidity for countries with very cold climates).

In order to exclude measurement errors caused by different hysteresis behaviour of the material's moisture, the sample should be dried at first and hereafter acclimated to the specific climate.

In some other standards, e.g. IEC 60079-0, different limit values based on measurement taken at 50 % RH or 30 % RH have been specified in the past in the absence of an effective dehumidified test chamber. Experience shows that measurement results in this climate are not obtained with the same degree of consistency as those measured according to this standard. However, it may be necessary to use the climate specified in other standards in order to maintain continuity for previously evaluated equipment.

It may be that it is difficult to apply the exact test methods specified in this standard to all types of equipment and in all situations. If this is the case, the test report shall clearly state which parts of this standard have been applied in their entirety and which parts of this standard have been applied in part. This shall be accompanied by a technical justification of why the standard could not be applied in its entirety and the equivalence of any other methods that have been applied compared with the methods specified in this standard.

CAUTION: The test methods specified in this standard involve the use of high voltage power supplies and in some tests flammable gases that may present hazards if handled incorrectly. Users of this standard are encouraged to carry out proper risk assessments and pay due regard to local regulations before undertaking any of the test procedures.

4.2 Surface resistance

4.2.1 General

Surfaces which have a sufficiently low surface resistance as defined in 3.11 cannot be electrostatically charged when in contact with earth. For this reason, surface resistance is a basic electrostatic property concerning the ability of materials to dissipate charge by conduction. As surface resistances usually increase with decreasing relative humidity, a low relative humidity is necessary during measuring to replicate worst case conditions.

IEC 60093 and IEC TR 61340-2-3 describe methods for measuring surface and volume resistance and resistivity of solid planar materials. IEC 61340-4-10 is an alternative method for measuring surface resistance. However, often these methods cannot be applied because of the size and shape of materials, especially when incorporated into equipment and apparatus. For this reason, the test method for resistance measurements for non-planar materials and products with small structures specified in IEC 61340-2-3, or the following method may be used as a suitable alternative.

4.2.2 Principle

The surface is contacted with two conductive electrodes of defined length and distance and the resistance between both electrodes is measured. As high resistances usually decrease with increasing voltage, the applied voltage shall be increased to at least 500 V, preferably 1 000 V, at very high resistances.

NOTE Latest knowledge indicates that it may be advantageous to measure high resistances at 10 kV. However, in this case sparking has to be prevented, for example by an insulating foam between the electrodes, and the acceptance criteria have to be modified.

When thin insulating layers are backed with a more conductive material, the applied voltage can burn through to the material below, and the results obtained are inconclusive.

4.2.3 Apparatus

The measuring apparatus according to IEC 60079-0 consists of two parallel electrodes with the dimensions given in Figure 1. This may be realized by electrodes painted with silver paint through a suitable stencil, soft conductive rubber strip electrodes on spring-mounted metal tongues or conductive foam strips mounted on an insulating support.

Dimensions in millimetres

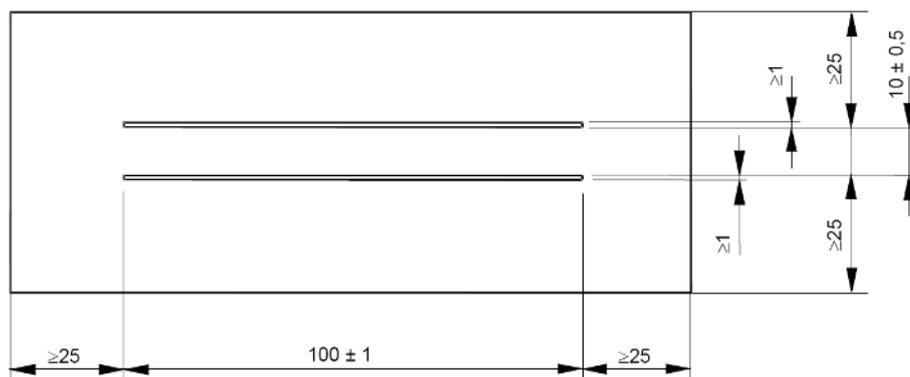

IEC

Figure 1 – Test sample with applied electrodes (dimensions in mm)

NOTE 1 The surface resistance is dependent upon the electrode configuration.

NOTE 2 This electrode configuration is also used e.g. in IEC 60167.

Non-homogeneous materials, particularly fabrics, may give different results when measured in different directions. Using a concentric ring electrode system, as described in IEC 61340-2-3 or ISO 14309, can avoid this issue.

Soft conductive rubber strip electrodes are preferred over silver paint electrodes to limit unwanted chemical surface interaction.

In case of uneven samples, silver paint electrodes are preferred over soft electrodes because of their better adaption to the uneven sample geometry.

The >25 mm criterion for the area around the electrodes as given in Figure 1 applies to test sheets only, it may be ignored in the case of real products.

The electrodes are connected to a teraohm meter. A guard shield electrode may be placed over the electrodes to minimise electric noise. During the test, the voltage shall be sufficiently

steady so that the charging current due to voltage fluctuation will be negligible compared with the current flowing through the test sample.

The accuracy of the teraohm meter shall be regularly tested with several resistances of known value in the interval 1 M Ω to 1 T Ω . The teraohm meter shall read the resistance within its stated accuracy. The geometry of conductive rubber or foam electrodes shall also be regularly checked by measuring their imprint. If the electrode force to reach the minimum resistance is higher than 20 N, the rubber electrodes shall be replaced by softer ones.

4.2.4 Test sample

The surface resistance shall be measured on the parts of the actual specimen if size permits, or on a test sample comprising a rectangular plate with dimensions in accordance with Figure 1. The test sample shall have an intact clean surface. As some solvents may leave conductive residues on the surface or may adversely affect the electrostatic properties of the surface, it is best to clean the surface with a brush only. This is especially important in cases where the surface is treated with special antistatic agents.

If, however, fingerprints or other dirt is visible on the surface and no special antistatic agents are used on the surface the test sample shall be cleaned with 2-propanol (isopropyl alcohol) or any other suitable solvent that will not affect the material of the test sample and the electrodes, and then dried in air.

It shall then be conditioned for at least 24 h at (23 ± 2) °C and (25 ± 5) % relative humidity without being touched again by bare hands. In the case of enclosures for electrical equipment, the climate given in IEC 60079-0 and a test voltage of 500 V shall be used to be compatible with historic measurements.

4.2.5 Procedure

The measurement procedure is as follows:

- 1) Carry out the test under the same climate as the pre-conditioning.
- 2) Place the sample on an insulation pad with a surface resistance exceeding 10 T Ω .
- 3) Place the electrodes on the surface of the sample.
- 4) Apply a force of 20 N on the electrodes (not necessary in the case of painted electrodes).
- 5) Apply a measuring voltage of $(10 \pm 0,5)$ V for (15 ± 5) s between the electrodes.
- 6) Measure the resistance between both electrodes and record the value at the end of the measuring time.

NOTE 1 Starting with low measuring voltage is necessary to avoid damage of the electrodes caused by high currents when measuring low resistance samples.

- 7) If the resistance is between 1 M Ω and 10 M Ω , the measuring voltage shall be increased to (100 ± 5) V for (15 ± 5) s. Resistances between 10 M Ω and 100 M Ω shall be measured with (500 ± 25) V for (65 ± 5) s. In case of surface resistances exceeding 100 M Ω apply a voltage of at least (500 ± 25) V, preferably $(1\ 000 \pm 50)$ V, for (65 ± 5) s.

NOTE 2 In IEC 60079-0, one voltage of 500 V is applied.

NOTE 3 In IEC 61340-4-1, 100 V is applied for resistances between 1 M Ω and 100 G Ω , and 500 V for even higher ones. In IEC 61340-2-3, 100 V is applied for all resistances above 1 M Ω . As high resistances usually decrease with increasing voltage and needs a longer time for stable results, measuring of high resistances at the stated higher voltages and measuring times is recommended.

- 8) Repeat the measurement nine times at different places on the same sample or using additional samples, unless either the sample is too small for this to be practical, or the range of the results is within ± 10 %. In this case, a lower number of repeats is acceptable. However, there should be a minimum of 3 tests in total.

4.2.6 Acceptance criteria

The pass/fail criteria given in the standard which calls for the test method apply. If specific pass/fail criteria are not given, guidance is provided in IEC TS 60079-32-1.

Test samples shall be classified according to the measured resistance at the highest measuring voltage. For example, if the resistance at 10 V is 1,5 MΩ, and at 100 V is 900 kΩ, the test sample shall be classed as having a resistance of 900 kΩ.

4.2.7 Test report

The test report shall include at least the following information:

- measuring laboratory,
- date of measurement,
- temperature and relative humidity,
- description and identification of the sample,
- test results,
- applied measuring voltage,
- number of measurements,
- geometric mean resistance,

NOTE Geometric mean is calculated by taking the nth root of the product of n values:

$$\bar{x} = \left(\prod_{i=1}^n x_i \right)^{1/n}$$

For example, the geometric mean of five values 1, 2, 5, 50 and 100 is $(1 \times 2 \times 5 \times 50 \times 100)^{1/5} = 8,71$.

Geometric mean is of more practical significance than arithmetic mean when averaging values that vary by orders of magnitude, as is often the case when making resistance measurements. For example, five resistance measurements may include four measurements of the order of 1 GΩ and one measurement of 1 TΩ. The arithmetic mean is weighted by the 1TΩ measurement, whereas the geometric mean is not and more closely represents the overall way a material is likely to perform in practice.

- identification of the instrumentation used,
- number of this standard.

4.3 Surface resistivity

The surface resistivity is ten times higher than the surface resistance measured with the electrode geometry used in the surface resistance measurement in 4.2.

4.4 Volume resistivity

The surface resistance or resistivity is a more significant factor in determining the electrostatic chargeability of a material than volume resistivity. As the volume resistivity of the material is less relevant in this context, its measurement is not described in this document. Nevertheless, the volume resistivity can be an important factor with regard to the practical earthing requirements for an item. If required, the procedure specified in ISO 14309 for rubber or thermoplastic materials, or in IEC 61340-2-3 for dissipative materials, or in IEC 60093 for insulating materials shall be used for determining the volume resistivity of a material.

4.5 Leakage resistance

4.5.1 General

The leakage resistance of an object, especially of flooring, is an important electrostatic safety characteristic. There are several standards published with different measuring methods for testing the leakage resistance of a floor which mostly can be applied to other objects (e.g. rotating cylinders, housings, bags with an earthing point). In IEC 61340-4-1 the test is executed with a circular electrode, (65 ± 5) mm in diameter pressed to the floor with $(2,5 \pm 0,25)$ kg (hard floor) or $(5,0 \pm 0,25)$ kg (soft floor). In ISO 10955 measurement is done with a circular electrode, (65 ± 2) mm in diameter pressed to the floor with $(5,0 \pm 0,1)$ kg. ASTM F150 uses a circular electrode, 63,5 mm in diameter pressed to the floor with 2,5 kg. EN 1081 uses a three-footed electrode pressed to the floor by a person standing on it. As each method yields a somewhat different resistance it is important that the measuring method used is stated in product specifications and test reports.

NOTE In ideal cases the differences between the measured resistances of the different methods described above are small. In reality, rough surfaces, e.g. external concrete forecourts with significant stone content standing proud might influence the measured resistance depending on the used electrode surface and the applied pressure. Improved results might be obtained with conductive foam pads under IEC 61340-4-1 electrodes to take up roughness of several mm. However, this might not replicate the practical situation of a person's footwear with hard soles.

Since the leakage resistance may be within the conductive or dissipative range (see IEC TS 60079-32-1), its measurement shall be started with a low voltage of 10 V and then increased as already stated in 4.2. If measuring within potentially explosive atmosphere is necessary, e.g. on filling stations, a measuring voltage of (100 ± 5) V should not be exceeded to prevent incendive spark discharges.

4.5.2 Principle

The floor or object is contacted with a specified electrode and the resistance between electrode and earth is measured.

4.5.3 Apparatus

Usually, a circular electrode, (65 ± 5) mm in diameter with a conductive rubber surface is pressed to the object with 2,5 kg, or 5 kg which is within the electrode specification of nearly all standards cited in 4.5.1. However, three-footed electrodes described in EN 1081 may be more suitable if simulation of the body pressure on the floor is important.

NOTE Measured resistance tends to decrease with increasing electrode pressure, but only up to a certain point, after which further increase in pressure has little effect on measured resistance. It has been found that for many flooring materials, the pressure applied by a 5 kg, 65 mm diameter electrode is adequate for accurate measurement.

The electrodes are connected to a teraohm meter. A guard shield electrode may be placed over the electrode to minimise electric noise. During the test, the voltage shall be sufficiently steady so that the charging current due to voltage fluctuation will be negligible compared with the current flowing through the test sample.

The accuracy of the teraohm meter shall be regularly checked with high resistances of known value. If the force applied by the electrodes required to reach the minimum resistance on a test sample is higher than 20 N, the rubber electrodes shall be replaced by softer ones.

4.5.4 Test sample

The test floor or object shall have an intact clean surface. If the floor or object being measured is outside (e.g. forecourt surfaces at filling stations), there shall have been no rainy or foggy weather within 24 h before the measuring time (relative humidity over 50 %). Floors or objects intended to be used inside shall be conditioned at (23 ± 2) °C and (25 ± 5) %

relative humidity for 24 h for laboratory measurements, or under ambient conditions for in situ measurements.

Additional conditioning time may be required for textile floor covering and other materials that readily absorb moisture (see ISO 10965).

4.5.5 Procedure

The test shall be carried out according to 4.2.5. except that measurement takes place between one electrode and earth. In the case of floors, the number of measurements made shall be agreed between the parties and selected taking account of the reason for making measurements (qualification, auditing, etc.), the expected homogeneity of the floor covering or substrate, and the total area of the floor concerned. When auditing large floor areas in factories or warehouses, one measurement per 100 m² may be acceptable, whereas qualification of critical areas where homogeneity of the floor covering is not known may require one or more measurements per 1 m².

4.5.6 Acceptance criteria

The pass/fail criteria given in the standard which calls for the test method apply. If specific pass/fail criteria are not given, guidance is provided in IEC TS 60079-32-1.

4.5.7 Test report

The test report shall include at least the following information:

- measuring laboratory,
- date of measurement,
- temperature and relative humidity,
- description and identification of the sample,
- test results,
- measuring voltage,
- electrode description,
- applied pressure,
- number of measurements,
- geometric mean resistance,
- identification of the instrumentation used,
- number of this standard.

4.6 In-use testing of footwear

4.6.1 General

Laboratory testing of footwear is described in IEC 61340-4-3 and IEC 61340-4-5. In situ testing of footwear and flooring is also described in IEC 61340-4-5. For regular daily testing, the earth leakage resistance of a person wearing footwear can usually be determined with footwear conductivity testers (Personnel Grounding Tester). If such a device is not available, this resistance shall be measured according to the following sections.

4.6.2 Principle

The resistance between a hand-held object and a metal plate where a person stands with both feet is measured. The resistance of the person is assumed to be negligible compared to the resistance of the shoes.

4.6.3 Apparatus

The measuring device consists of a metal plate on the floor and a hand-held metal object (e.g. a metal bar of 20 mm in diameter and 100 mm in length or a metal sphere 50 mm in diameter). A teraohm meter is connected between both electrodes measuring the resistance between hand-held metal object to the metal plate via body and feet. The accuracy of the teraohm meter shall be regularly checked with a high resistance of known value.

The measuring voltage shall not exceed 100 V to prevent an electric shock. When measuring with 100 V a protecting resistor of about 1 M Ω shall be within the measuring circuit. This resistor may be omitted when measuring low resistance with 10 V.

4.6.4 Procedure

The measurement procedure is as follows:

- 1) Measure at (23 ± 2) °C and (25 ± 5) % relative humidity. If the relative humidity is exceeded, record the humidity.
- 2) Put on the shoes to be tested.
- 3) Wait five minutes to get sufficient humidity in shoes and socks.
- 4) Stand on the metal plate with both feet and grasp the metal object with one bare hand.
- 5) Record the displayed resistance of the footwear.

4.6.5 Acceptance criteria

The pass/fail criteria given in the standard which calls for the test method apply. If specific pass/fail criteria are not given, guidance is provided in IEC TS 60079-32-1.

4.6.6 Test report

In case of routine controls, a result in form of a red or green lamp or other indicators is sufficient provided the resistance limits associated with each indicator corresponds to the acceptance criteria specified in 4.6.5. In all other cases, the test report shall include at least the following information:

- measuring laboratory,
- date of measurement,
- temperature and relative humidity,
- description and identification of the sample,
- test results,
- measuring voltage,
- number of measurements,
- identification of the instrumentation used,
- number of this standard.

4.7 In-use testing of gloves

4.7.1 General

Laboratory testing of gloves is described in prEN 16350. For regular daily testing, the resistance of gloves may be measured together with the resistance of footwear. Unfortunately, this total resistance cannot always be determined with footwear conductivity testers (Personnel Grounding Tester). It may, therefore, be necessary to measure the resistances as follows.

4.7.2 Principle

The resistance between a glove-held and a hand-held metal object via body and feet to a metal plate on which the person stands with both feet is measured according to 4.6. If the resistance of the footwear is not known, the resistance between glove-held metal object and a wrist strap of known resistance on the person's arm shall be measured.

4.7.3 Apparatus

Same as in 4.6.

4.7.4 Procedure

The measurement procedure for persons earthed via their footwear is as follows:

- 1) Measure the resistance of the used footwear as described in 4.6.4.
- 2) Repeat the measurement with gloves on the hand.
- 3) Report both values and their quotient.

The measurement procedure for persons earthed via wrist straps is as follows:

- 1) Earth the person via a wrist strap of known resistance.
- 2) Measure the resistance between the glove held metal object and the wrist strap.
- 3) Report both values and their difference.

4.7.5 Acceptance criteria

The pass/fail criteria given in the standard which calls for the test method apply. If specific pass/fail criteria are not given, guidance is provided in IEC TS 60079-32-1.

4.7.6 Test report

The test report shall include at least the following information:

- measuring laboratory,
- date of measurement,
- temperature and relative humidity,
- description and identification of the sample,
- resistance of wrist-strap or footwear,
- test results,
- measuring voltage,
- number of measurements,
- identification of the instrumentation used,
- number of this standard.

4.8 Powder resistivity

4.8.1 General

Different measuring methods exist for powder resistivity: measuring cell according to IEC TS 61241-2-2 (groove cell), according to IEC 60093 (stamp cell) and a concentric cell with an outer and an inner ring electrode (Lucas, 2011, Stahmer et al, 2012¹). According to Stahmer et al, groove cell and concentric cell yield the same results. However, as a consequence of

¹ See bibliography.

the compression of the powder, the stamp cell gives an up to ten times lower resistivity when measuring compressible powders. For these reasons, the powder resistivity shall be measured according to the following procedure based on IEC TS 61241-2-2. The test method may be used for evaluating powders for reasons other than electrostatic safety, for example to determine if a powder is conductive enough to present a risk of short-circuiting powered electrical equipment. When testing for other purposes, it may be necessary to use multiple test voltages and to carry out more extensive analysis to fully characterise the powder and the risk associated with its use.

Measured resistance of some powders can change dramatically with a change in test voltage. Test voltages shall be chosen that are representative of practical risks, and test reports shall include results obtained at all test voltages to enable full analysis to be made if required.

4.8.2 Principle

A constant volume of powder is filled in a specific measuring cell with two electrodes. The resistance between both electrodes is measured.

NOTE The resistance of powders is highly dependent on particle size and bulk density.

4.8.3 Apparatus

A measuring cell according to IEC TS 61241-2-2 consisting of two opposing electrodes of polished stainless steel bars (1) mounted together with two opposing walls of insulating glass bars or other insulating material (2) on a insulating base (4) shall be used (Figure 2). The thickness of the electrodes shall be between 5 mm and 10 mm. The resistance R between the electrodes shall exceed $100\text{ T}\Omega$. The exact values of the dimensions of the cell have to be known for the geometric correction factor in 4.8.4.

NOTE In IEC 61241-2-2, in spite of the requirement for high insulation resistance, glass bars are specified for the opposing walls.

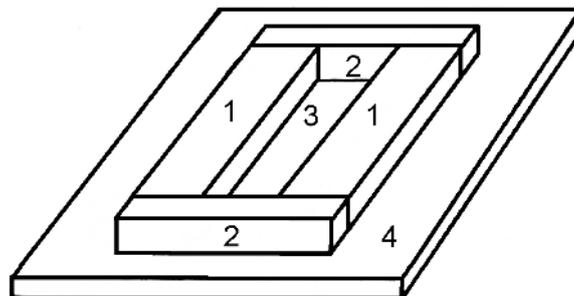

IEC

Key

- 1 polished stainless steel bars, (10 ± 1) mm in height, (100 ± 1) mm in length and (10 ± 1) mm distance
- 2 insulating glass bars, same height as 1
- 3 cell to fill in powder
- 4 insulating base

Figure 2 – Measuring cell for powder resistivity

The electrodes are connected to a teraohm meter. The accuracy of the teraohm meter shall be regularly tested with resistances of known value in the region $1\text{ M}\Omega$ to $1\text{ T}\Omega$. The teraohm meter shall read the resistance within its stated accuracy. A guard shield electrode may be placed over the measuring cell without contacting the electrodes to minimise electric noise as proposed in JNIO SH TR42. During the test, the voltage shall be sufficiently steady so that the

charging current due to voltage fluctuation will be negligible compared with the current flowing through the test sample.

4.8.4 Procedure

The measurement procedure is as follows:

- 1) Acclimate the test powder to (23 ± 2) °C and (25 ± 5) % relative humidity for at least 24 h. Powders which significantly dry up or absorb water and for which the powder resistance during a special technological process is important shall be measured at the climate conditions of this process.
- 2) Pour a quantity of the original untreated test powder between the test electrodes (3).
- 3) Remove excess powder by running a straight-edge along the top of the stainless steel bars (1).
- 4) Measure the resistance R of the filled test cell between the electrodes (1) with the following values of DC voltage applied for 10 s: (105 ± 10) V, (500 ± 25) V, $(1\ 000 \pm 50)$ V. The same sample of powder in the test cell may be used for all the tests at any one of the values of voltage. If no constant measuring value is reached after 10 s the measuring time shall be elongated to (65 ± 5) s.

NOTE Perrin et al, 2007², recommend using at least 500 V and 1000 V, flushing the sample with a playing card and using a measuring time of at least 60 s. However, higher voltages can lead to unwanted physical or chemical effects that could give misleading results when evaluating powders for electrostatic safety purposes.

- 5) Calculate the resistivity ρ at all test voltages from the equation

$$\rho = 0,001 \times R \times H \times \frac{W}{L}$$

where R is the resistance in Ω , ρ is the resistivity in Ωm , H is the height of the electrode in mm, W is the length of the electrode in mm and L is the space between electrodes in mm.

- 6) Repeat steps 2 to 5 twice and calculate the average value for each test voltage.

4.8.5 Acceptance criteria

The pass/fail criteria given in the standard which calls for the test method apply. If specific pass/fail criteria are not given, guidance is provided in IEC TS 60079-32-1.

4.8.6 Test report

The test report shall include at least the following information:

- measuring laboratory,
- date of measurement,
- temperature and relative humidity,
- description and identification of the sample,
- measuring voltage(s),
- test results for each measuring voltage,
- number of measurements for each measuring voltage,
- identification of the instrumentation used,
- number of this standard.

² See bibliography.

4.9 Liquid conductivity

4.9.1 General

Usually, conductivity meters with dip electrodes are sufficiently exact for electrostatic purposes. In any case, the liquid temperature shall also be reported because conductivity is strongly dependant on liquid temperature.

If more exact values are needed, a specific test cell such as the cell described in the following section shall be used. The cell can be used for single phase and stable multiphase liquids. Alternatively, the conductivity may be determined according to IEC 60247.

4.9.2 Principle

A defined volume of liquid is poured into a specific measuring cell with two electrodes. The resistance between both electrodes is measured.

4.9.3 Apparatus

Figure 3 describes a measuring cell (taken from DIN 51412-1) with a cell constant K of 1/m. Other cell dimensions are possible but the cell constant of the arrangement has to be determined from geometry. A DC voltage U of (100 ± 1) V shall be applied between the inner and the outer electrode. The resistance may be measured directly or, for a more precise result (particularly if the resistance measurement is unstable), the resulting current I may be recorded with a picoammeter coupled to a device able to record charge decay (e.g an oscilloscope or Personal Computer).

Dimensions in millimetres

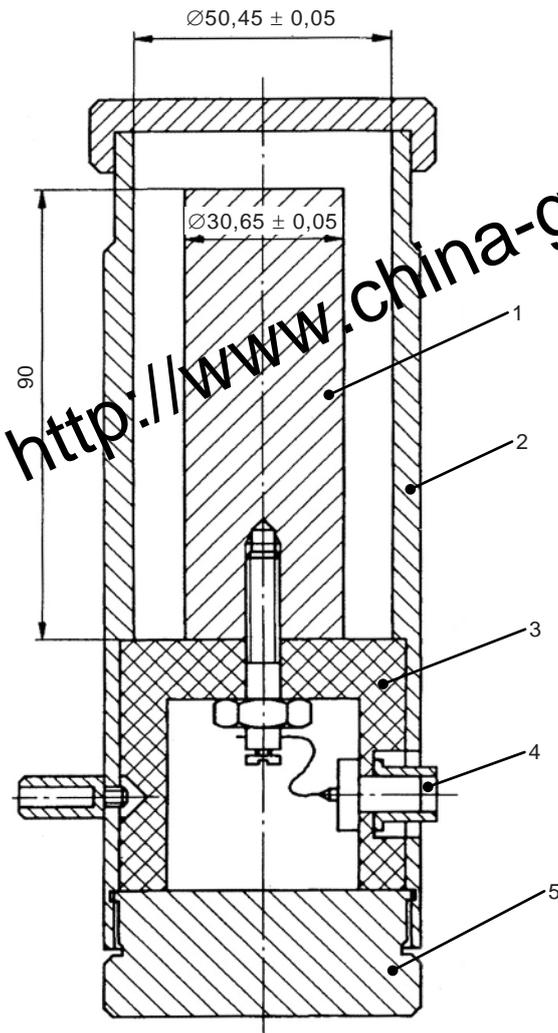

IEC

Key

- 1 inner electrode (aluminum)
- 2 outer electrode (aluminum)
- 3 isolation ring (PTFE)
- 4 BNC
- 5 stopper (Cu-Ni alloy)

Figure 3 – Measuring cell for liquid conductivity

If the liquid measured reacts with aluminium, the material of the electrodes of the cell should be replaced with an appropriate material, such as stainless steel.

4.9.4 Procedure

The measurement procedure is as follows:

- 1) Wash the measuring cell at least three times with the untreated test liquid. If insufficient test liquid is available, wash the cell with a pure insulating reference liquid (e.g. hexane).
- 2) Pour $(100 \pm 0,5)$ cm³ of the original untreated test liquid in the measuring cell and close it with the lid.

- 3) Measure the resistance R of the filled test cell directly between the electrodes at 100 V applied for 10 s with a high ohmic resistance meter.

NOTE In most cases, a test voltage of 100 V is sufficient. Higher voltages can lead to unwanted physical or chemical effects that could give misleading results when evaluating liquids for electrostatic safety purposes, but may be needed when testing for other purposes. For measuring conductivities above 1 pS/m, lower voltages, i.e. 10 V as originally proposed, may be sufficient.

- 4) If the measured resistance is strongly decreasing, measure the course of the current I with an oscilloscope or Personal Computer coupled to a picoammeter, etc. If the result is still unstable or if a more precise value is required, the measuring time shall be elongated to (65 ± 5) s.
- 5) Extrapolate the current I_0 for $t = 0$ from the recorded course of I or $R = U/I$.
- 6) Calculate the conductivity σ in S/m according to

$$\sigma = K \times \frac{I_0}{U}$$

1 pS/m = 10^{-12} S/m = 1 cu (conductivity unit)

- 7) Repeat the procedure twice

4.9.5 Acceptance criteria

The pass/fail criteria given in the standard which calls for the test method apply. If specific pass/fail criteria are not given, guidance is provided in IEC TS 60079-32-1.

4.9.6 Test report

The test report shall include at least the following information:

- measuring laboratory,
- date of measurement,
- temperature of the liquid,

NOTE The conductivity of liquids strongly depends on their temperature.

- description and identification of the sample,
- geometric mean conductivity,
- measuring voltage,
- number of measurements,
- identification of the instrumentation used,
- number of this standard.

4.10 Capacitance

4.10.1 General

Avoiding isolated conductors with significant capacitance is one of the most important electrostatic rules. For this reason only small isolated conductive objects with low capacitances are allowed in hazardous areas. To check whether the suspected conductive object (e.g. metal screws of an enclosure, metal connecting sockets of hand-held equipment) is within the allowed limits, the following test shall be conducted. Metal sockets and contacts which are situated so deep in an enclosure that discharges to approaching earthed objects are not expected need not be tested.

Measurement of small capacitances of the order 3 pF should be considered to be subject to questionable reliability, and those near 6 pF and 10 pF should be considered to be subject to considerable uncertainty. Consideration should be given to additional measurements for transferred charge and/or ignition testing.

4.10.2 Principle

The test sample is placed on an unearthed metallic plate and the capacitance between exposed conductive parts and the metallic plate is measured with a capacitance meter.

4.10.3 Apparatus

The measuring device consists of an unearthed metal plate (resistance to earth shall be greater than $10\ \text{T}\Omega$) that significantly exceeds the area of the test sample and a capacitance meter able to measure between 1 pF and 10 pF with a measuring uncertainty of less than 0,5 pF at a measuring frequency of at least 1 000 Hz. The applied voltage shall be between 1 V and 9 V. The negative measurement lead is connected to the metal plate. The positive lead is freely available for capacitance measurement. The connection leads shall be as short as possible to avoid stray currents. Metallic plates with surface oxidation shall be avoided as this may lead to erroneous results.

A battery powered capacitance meter may be necessary to ensure stable readings without earth loops.

Other electrical equipment, especially fluorescent lamps, shall be kept at least two metres away from the test sample.

4.10.4 Test sample

The test shall be carried out on a fully assembled sample of the equipment. The sample shall be conditioned in a climatic conditioning chamber for min 24 h at a temperature of $(23 \pm 2)\ ^\circ\text{C}$ and a relative humidity of $(25 \pm 5)\ \%$.

NOTE Geometrical arrangement and humidity can influence the capacitance of unearthed conductive objects.

4.10.5 Procedure for moveable items

This procedure is for items where the geometry of exposed metallic parts with respect to earth is not fixed. In this case, the capacitance between each exposed metallic part on the test sample and the metal plate shall be measured as follows:

- 1) Place the sample on the metal plate. The conductive part of the sample to be measured shall remain isolated from the plate. If the sample requires support, it may be held in position with clamps made of insulating material, but shall not be held by hand.
- 2) The positions of the samples are to be such that the exposed metallic test point being measured is as close as possible to the unearthed metal plate without contacting the plate. However, if the external metal part is in electrical contact with internal metal parts, it is necessary to measure the capacitance in all orientations of the equipment to ensure that the maximum capacitance has been determined.

If a metallic part is not easily accessible to the meter leads, a screw may be inserted to extend the part and create a test point. The screw shall be small compared to the metallic part and may not make electrical contact with any other internal metal part.

Stray capacitance shall be minimized by keeping conductive items and the human body at least 50 cm away from the sample under test.

- 3) Connect the negative measurement lead of the capacitance meter to the unearthed metal plate.
- 4) Position the positive measurement probe of the capacitance meter 3 mm to 5 mm away from the metallic test point and as far as possible from the metal plate. Record the value of this stray capacitance in air to the nearest pF.
- 5) Place the positive measurement lead of the capacitance meter in contact with the metallic test point and record the value of the capacitance to the nearest pF.
- 6) Compute the difference between the measurements in steps 4 and 5, and record the value.

- 7) Repeat steps 4 through 6 twice for each test point.
- 8) Calculate the average capacitance from the three measurements obtained. If a small screw has been added to facilitate measurement as described in Step 2, its capacitance shall be considered and subtracted from the measured value.
- 9) Calculated capacitances less than 3 pF shall be reported as < 3 pF.

In cases where the capacitance of an isolated metal part is expected to be higher to other metal parts of the object than to earth, this capacitance shall additionally be measured and evaluated.

4.10.6 Procedure for installed items

This procedure is for installed items where the distance and geometry of metallic parts are fixed with respect to earth. In this case, the capacitance between each exposed metallic part on the test sample and earth is to be measured in installed condition (e.g. metal parts within an earthed metal tank system). Under worst case conditions. An unearthed counter metal plate is not needed. Measure the capacitance as follows:

- 1) Connect the negative measurement lead of the capacitance meter to an earth point. The positive measurement lead of the capacitance meter shall be as short as possible and kept as far as possible from that cable.
- 2) Follow steps 4 to 9 of the test procedure described in 4.9.5.

4.10.7 Acceptance criteria

The maximum allowed capacitance depends on the type of the hazardous area. If the maximum allowed capacitance is not given in the standard that calls for this test method, guidance is provided in IEC TS 60079-32-1.

4.10.8 Test report

- The test report shall include at least the following information:
- measuring laboratory,
- date of measurement,
- temperature and relative humidity,
- description and identification of the sample,
- arithmetic mean capacitance,
- measuring voltage,
- measuring frequency,
- number of measurements,
- identification of the instrumentation used,
- number of this standard.

4.11 Transferred charge

4.11.1 General

According to IEC 60079-0 and IEC TS 60079-32-1, the maximum allowed surface area of insulating materials is limited in explosive atmospheres. However, there are many cases where a sufficient safety level is still achieved with insulating materials. These cases include surfaces with embedded corona tips, enclosures backed with printed boards as well as materials with an internal breakdown voltage of only a few kilovolts. For this reason the following charging test may be executed with the evaluated object if surface area requirements cannot be fulfilled.

In some cases, a different test arrangement is more relevant to the specific situation. For example, in the case of evaluating fuel pipes located in explosive atmospheres, a

measurement of the charge generated on the pipe by streaming high chargeable fuels under worst case conditions is preferred.

NOTE 1 One of the highest chargeable liquids is toluene in technical quality. However, toluene presents a significant fire risk. Therefore, in SAE J1645 a technical hydrodesulfurated heavy naphtha, boiling range up to 200 °C, flashpoint 40 °C, is proposed (commercial name: white spirit (type 2:regular), Stoddard solvent³, or Testbenzin⁴).

In the case of garments, the test may produce results which conflict with other established test methods. For this reason, garments are usually tested by the method of charge decay in 4.12 or EN 1149-3.

NOTE 2 Detailed work on this topic has been published in the committee CEN/CENELEC SUCAM document BT147/DG9292/DC.

Transferred charge measurements tend to show a high degree of operator dependence and variability owing to imperceptible differences in charging conditions and rubbing materials. When transferred charge measurements are used for certification purposes, it is recommended that laboratories co-operate in regular and frequent round robin trials to minimise inter-laboratory variability.

4.11.2 Principle

The maximum charge transferred by a discharge under worst case conditions is sometimes used to give an indication of the maximal expected incendivity of spark and brush discharges instead of using ignition tests in explosive atmosphere.

4.11.3 Apparatus

The following items are needed:

- 1) A table or rigid sheet of dissipative material, e.g. untreated wood;

NOTE 1 The correct use of a dissipative table surface guarantees a strong charge accumulation on the charged surface due to charge binding effects. After lifting the sample from the table the charges are no longer bound by opposite charges of the table yielding optimal conditions for discharging.

- 2) Cloths made of materials free from finishes from the positive and negative end of a triboelectric series large enough to avoid contact between the test sample and the fingers of the testing person during the rubbing process, and a glove or other piece of smooth natural leather.

NOTE 2 See IEC TR 61340-1 for a triboelectric series.

NOTE 3 Suitable positive materials for tribocharging include: smooth natural leather, sheep wool felt, polyamide cloth for rain coats, cotton, and cat fur. Suitable negative materials for tribocharging include polyurethane and polyethylene table cloth.

- 3) A single pointed metal needle electrode or multi-needle electrodes having a connection of the electrode(s) to the negative pole of a high voltage power supply of 30 kV to 70 kV dc for corona charging.
- 4) One of the following or equivalent equipment for measuring charge transfer:
 - a) A polished metal electrode of (25 ± 5) mm in diameter coupled to the 50Ω input of an oscilloscope of at least 1 Giga-samples/s and 300 MHz bandwidth having a circular arranged earthed shunt resistance of $(0,25 \pm 0,05) \Omega$ of at least 300 MHz in bandwidth (von Pidoll⁵), or

³ Known as Stoddard solvent in the US.

⁴ Known as Testbenzin in Germany.

⁵ See bibliography.

- b) A polished metal electrode of (25 ± 5) mm in diameter coupled to an earthed (100 ± 10) nF capacitor with a (15 ± 2) k Ω resistor in parallel, both connected to the input of a voltmeter automatically triggering and holding the highest value (Schnier⁶), or
- c) A polished metal electrode of (3 ± 1) mm in diameter in a smooth edged hole of (5 ± 1) mm in diameter of an earthed hollow sphere of (25 ± 5) mm in diameter, connected to an earthed (100 ± 10) nF capacitor at the input of a coulomb meter (Chubb⁷).
- d) A flat round disk, less than 3 mm thickness, made of PTFE with an area exceeding 20 000 mm² as a highly chargeable reference (Lepp⁸).

4.11.4 Test sample

The test shall be carried out on a fully assembled sample of the product or a material with the same fabrication parameters. This sample shall not have been previously subjected to other tests and may consist of any combination of insulating, conductive or dissipative materials.

It is advantageous to test the fully assembled product because charge binding effects, e.g. due to internal conductive items, may help to prevent hazardous discharges.

The sample shall be conditioned in an environmental conditioning chamber for at least 24 h at (23 ± 2) °C and (25 ± 5) %RH.

The test sample shall have an intact clean surface. As any solvent may leave conductive deposits on the surface it is best to clean the surface with a brush only. This is especially important in cases where the surface is treated with special antistatic agents.

If, however, fingerprints or other dirt is visible on the surface and no special antistatic agents are used on the surface the test sample shall be cleaned according to 4.2.4.

4.11.5 Procedure

All insulating parts of the test sample shall be tested. Conductive parts shall be earthed during testing if earthing is ensured during use.

The test is conducted as follows:

- 1) The correct operation of the measuring system shall be confirmed e.g. by test pulses of approximately 50 nC from a spherical electrode at the input of a calibrated electrostatic voltmeter of known input capacitance (e.g. 10 pF) and known applied voltage (e.g. 5 kV). Alternatively, a very short connection of a 1,5 V battery (typically 1,65 V) to the input of a coulombmeter (typically 100 pF input capacitance) shall display the transferred charge (typically 165 nC).
- 2) Check the test steps 3 to 12 with the reference PTFE disk and verify that at least 100 nC is obtained.
- 3) Rub the test sample with a material from the positive end of the triboelectric series at least one stroke per second with medium force (approximately 40 N), in the direction away from the test person. The test surface shall not be contacted with the bare hand. Rubbing shall continue for (10 ± 1) s and shall be terminated with a hard rubbing stroke.

NOTE 1 The medium force of 40 N might be measured by a weighing machine.

⁶ See bibliography.

⁷ See bibliography.

⁸ See bibliography.

NOTE 2 Suitable positive materials for tribocharging include: smooth natural leather, sheep wool felt, polyamide cloth for rain coats, cotton, and cat fur. Suitable negative materials for tribocharging include polyurethane and polyethylene table cloth.

- 4) Grab the sample by using an isolated grip to minimize inadvertent discharge.
- 5) Lift the sample carefully at least 20 cm away from the table losing as little charge as possible.
- 6) Discharge the sample as quickly as possible by slowly moving the spherical electrode of the measuring equipment towards the test sample until a discharge occurs. Particular attention shall be made to
 - a) Discharge the most hazardous parts of the sample e.g. great surface areas and small conductive items.
 - b) Discharges occurring at gaps less than 2 mm for Group IIA, 1 mm for Group IIB and 0,5 mm for Group IIC are less likely to move than expected by their transferred charge due to quenching effects at the electrodes.
- 7) Immediately remove the sample from the vicinity of the electrode.
- 8) Read the value from the display or integrate the recorded current (horizontal setting typically 40 ns/div) and multiply it with the known calibration factor. Experts' advice may be necessary if multiple discharges are recorded.
- 9) Repeat the steps 3 to 8 nine times without delay.
- 10) Repeat steps 3 to 9 with a material from the negative end of the triboelectric series.
- 11) Repeat steps 3 to 9 with a second material from the positive end of the triboelectric series
- 12) Repeat steps 3 to 9 with a third material or hit the sample five times with the smooth part of a leather glove, ten times.
- 13) Check whether the test sample contains insulating parts backed with a conductor or is dissipative or conductive. If yes, repeat steps 4 to 9 with a flicking charging process by a cotton cloth and then continue to step 16; if no, go to step 14.

NOTE 3 This is necessary to ensure that propagating brush discharges, which damage the measuring equipment, cannot occur.

- 14) Charge the sample by positioning the corona electrode slightly above the test sample and charge it with small circular motion. Circular motion is not necessary in case of a multi-needle electrode. Remove the electrode after 10 s far away from the sample while the high voltage is still applied in order to avoid back spraying of charges from the charged sample to the electrode.
- 15) Continue with steps 4 to 9.
- 16) End of Test

4.11.6 Acceptance criteria

The highest value of all charging methods shall be used for the assessment procedure.

The maximum allowed value depends on the type of the hazardous area. If the maximum allowed value is not given in the standard that calls for this test method, guidance is provided in IEC TS 60079-32-1.

Charging by corona and whipping with a leather glove are strong charge generating processes comparable to machine rubbing, charging by electrons in the vicinity of ionisers and electrostatic spraying equipment or charging by streaming liquids and powders.

4.11.7 Test report

The test report shall include at least the following information:

- measuring laboratory,
- date of measurement,

- temperature and relative humidity,
- description and identification of the sample,
- type of cloths used,
- corona voltage,
- maximum values obtained,
- number of measurements,
- maximum value obtained with the reference sample,
- identification of the instrumentation used,
- number of this standard.

If results on corona charging and whipping with a leather glove have been discarded, it shall be stated that the test sample may not be used in the presence of charge generating processes stronger than manual rubbing.

4.12 Ignition test

4.12.1 General

A second possibility to evaluate the incendiarity of provoked discharges under worst case conditions are experiments with an ignition probe producing a defined explosive atmosphere in the region of the provoked discharges. A suitable discharge probe is shown in Figure 4 and Figure 5 and is further described in IEC 61340-4-4.

Equipment other than that specified may be used if it reproduces the principles of the test and can give comparable results.

A round robin test is recommended to prove comparable results.

4.12.2 Apparatus

The ignition probe according to IEC 61340-4-4 is a cylinder made from rigid non-conductive material such as polycarbonate or acrylic with an internal diameter of (70 ± 5) mm and an internal length of (100 ± 5) mm (see Figure 4). The material used for constructing the probe shall be of sufficient thickness and strength to withstand repeated ignition without cracking, distorting or otherwise failing.

One end of the cylinder is closed apart from a central port to allow the inflow of the flammable gas. The size of the inlet port is not critical but shall be large enough to allow the required flow rate to be achieved without excessive pressure build-up. A suitable flame arrester shall be installed in the gas supply line as close as possible to the ignition probe.

A metal plate is fitted to the other end of the cylinder to form a fixing base for the discharge electrode (see Figure 5). The metal plate is drilled with holes, (5 ± 1) mm in diameter to allow the uniform flow of gas through it and around the discharge electrode.

A spherical metal electrode of diameter (20 ± 5) mm is mounted centrally to the metal plate. The electrode, metal plate and any other metal or conductive material in the ignition probe are connected to a common point earth via a low impedance ($<10 \Omega$) connection. The earth point shall be the common point earth for local structures and equipment. The common earth point may be connected to the electricity supply earth. The connection between the electrode, the metal plate and the earth connector shall be sufficiently robust to withstand physical and thermal impacts. The electrical continuity between the discharge electrode and the earth connector shall be checked prior to use.

The ignition probe is filled with glass or porcelain beads, nominally 1 mm to 2 mm diameter, which are retained by a fine metal gauze or mesh at either end of the main cylinder. The

beads assist in the mixing of the gases and also contribute to preventing propagation of any flame back through the probe.

An adjustable shroud made from insulating material is fitted to the cylinder to direct gas over the discharge electrode and into the region in front of the discharge electrode where electrostatic discharges take place. The opening in this shroud is (40 ± 5) mm.

The flammable gas is generated by mixing the test gas (minimum 99,5% purity) with air. The air used shall contain $(21,0 \pm 0,5)$ % oxygen and $(79,0 \pm 0,5)$ % nitrogen. The gas control and mixing apparatus is used to direct the gas in the appropriate proportions to the ignition probe. The test gases and their volume concentration to be used are given in IEC 60079-7 and shown in Table 1.

Table 1 – Volume concentrations of flammable test gas mixtures

| Test gas | Volume concentration | Minimum ignition energy* | Group |
|----------|----------------------------|--------------------------|-------|
| Hydrogen | (21 ± 2) % in air | 0,016 mJ | IIC |
| Ethylene | $(7,8 \pm 0,5)$ % in air | 0,082 mJ | IIB |
| Propane | $(5,25 \pm 0,25)$ % in air | 0,25 mJ | IIA |
| Methane | $(8,3 \pm 0,3)$ % in air | 0,28 mJ | I |

* See IEC TS 60079-32-1

NOTE The concentration interval in Table 1 represents centre value and range of the optimum ignition concentration plateau of the test gases. It is identical to the values in IEC 60079-7 and IEC 60079-11 and may slightly differ from the optimum ignition concentration at the point of MIE given in IEC/TS 60079-32-1. In IEC 60079-1, other concentrations representing the optimum ignition pressure and optimum flame transmission capability are used.

The control of the gas mixture within the specified tolerances shall be checked using, for example, a gas analyzer sampling the gas mixture supply line.

If a gas mixture other than that specified in Table 1 is used, the minimum ignition energy of the gas mixture shall be verified using the ASTM E582 method.

It is convenient to use compressed gas cylinders for the gas supply, but other sources of supply may be used. If necessary, molecular sieve filters shall be used to ensure the gases have low moisture content. This is particularly important, for example, when using air directly from a compressor.

Each gas supply is controlled and monitored using flowmeters and valves. The combined flow-rate of all gases through the ignition probe shall be $(0,21 \pm 0,04)$ l/s.

A fast action shut-off valve is used to stop the flow of test gas when ignition occurs. The shut-off valve shall stop the supply of test gas whilst leaving the air to flow freely to provide cooling and drying of the ignition probe after ignition has occurred. The type and location of the shut-off valve shall be selected as appropriate to the specific design of the overall apparatus.

Dimensions in millimetres

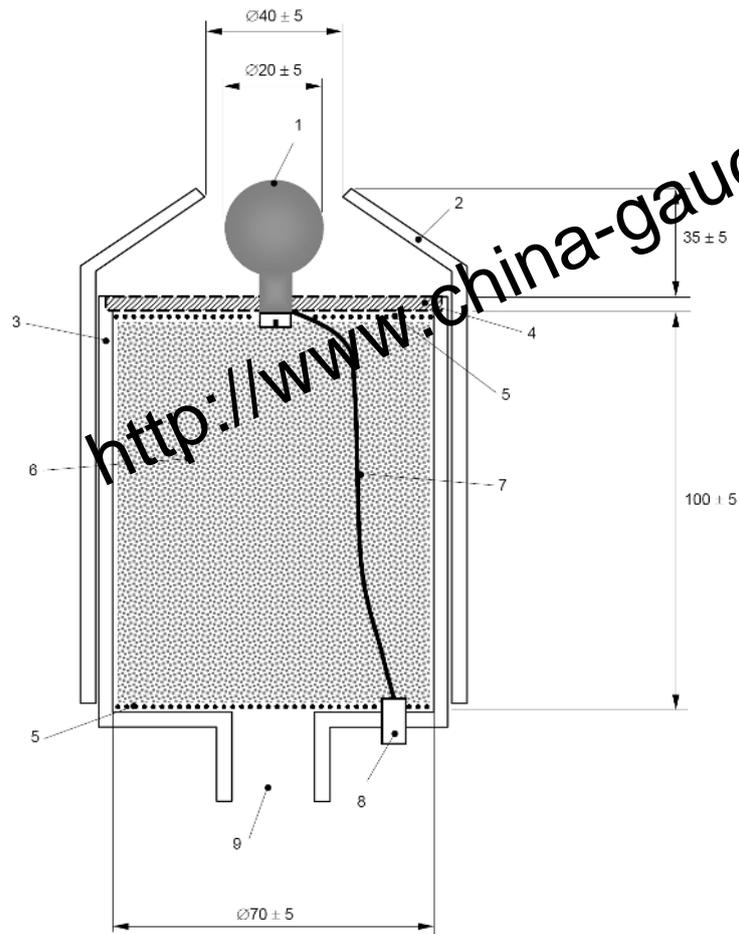

IEC

Key

- 1 discharge electrode
- 2 adjustable shroud made from insulating material (e.g. polycarbonate or acrylic)
- 3 cylinder made from insulating material (e.g. polycarbonate or acrylic)
- 4 perforated metal plate 2 mm nominal thickness)
- 5 fine metal mesh or gauze (e.g. copper)
- 6 beads (e.g. glass or porcelain) 1–2 mm diameter (nominal)
- 7 robust earth connection
- 8 earth connector
- 9 inlet port for flammable gas

Figure 4 – Ignition probe

Dimensions in millimetres

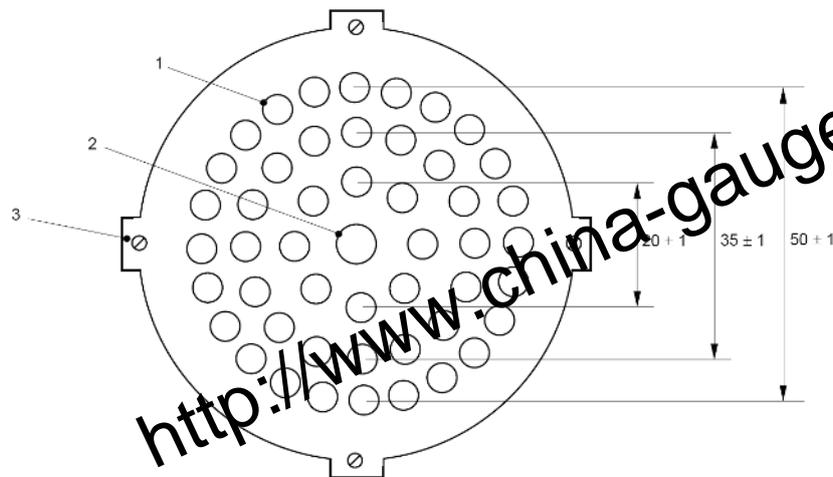

IEC

Key

- 1 perforation (5 ± 1) mm diameter
- 2 mounting hole for discharge electrode
- 3 screw for securing plate to body of ignition probe

Figure 5 – Perforated plate of ignition probe**4.12.3 Procedure**

Ignition tests are carried out by bringing the ignition probe close to the charged test sample with the flammable gas mixture flowing through the probe. The same test procedure as described in 4.10.5, steps 2 to 16, shall be executed except that the numbers of test sequences shall at least be doubled to compensate for statistical scatters.

4.12.4 Acceptance criteria

Any ignition occurring shall be regarded as product failure for the explosion group given by the specific gas mixture.

Charging by corona and whipping with a leather glove are strong charge generating processes comparable to machine rubbing, charging by electrons in the vicinity of ionisers and electrostatic spraying equipment or charging by streaming liquids and powders.

4.12.5 Test report

The test report shall include at least the following information:

- measuring laboratory,
- date of measurement,
- temperature and relative humidity,
- description and identification of the sample,
- type of cloths used,
- corona voltage,
- test gases used (concentrations and minimum ignition energy),
- ignition test results,
- number of non-ignitions obtained,

- whether ignition was obtained with the reference sample,
- identification of the instrumentation used,
- number of this standard.

4.13 Measuring of charge decay

4.13.1 General

Another possibility to evaluate the chargeability of a material, and one that is preferable for garments, is measuring of its charge decay according to the following test from IEC 61340-2-1.

NOTE In Europe, the method described in EN 1419-3 is used to determine charge decay from personnel protective clothing.

4.13.2 Principle

The material is charged by corona and the decay of its surface equivalent voltage, measured with a field meter, is recorded in between a given voltage interval.

4.13.3 Apparatus

An example of the apparatus is shown in Figure 6. The test aperture for deposition and measurement of deposited charge shall be (50 ± 1) mm diameter or an equivalent area quasi-square aperture. All the corona points are mounted in a (10 ± 1) mm diameter circle on a movable plate (10 ± 1) mm above the centre of the test aperture. The field meter sensing aperture shall be (25 ± 1) mm above the centre of the test area. When the plate with the corona points is moved fully away, the test area shall be clear up to the plane of the field meter sensing aperture.

The field meter shall be a field-mill type of instrument able to measure the surface voltage with an accuracy of ± 5 V below the lower limit of surface voltage that is required to be measured. The response time (10 % to 90 %) shall be at least one tenth of the fastest decay time required to be measured. The stability of zero shall allow measurements of surface voltage with this accuracy over the longest decay times to be measured. Any rest ionization in the measuring chamber shall be less than 10 V which can be evaluated with fully conductive materials.

The field meter shall be connected to a device able to record charge decay (e.g. an oscilloscope or a personal computer).

NOTE More details about this measuring procedure and drawings of the necessary apparatus can be found in IEC 61340-2-1.

Dimensions in millimetres

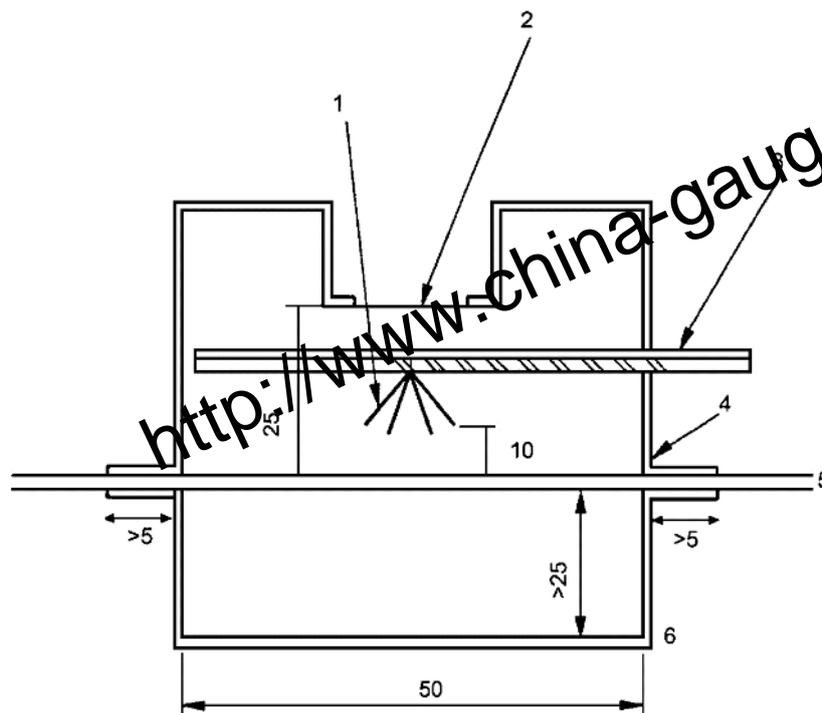

IEC

Key

- 1 10 mm diameter circle of corona points
- 2 fieldmeter sensing aperture
- 3 movable plate:
 - insulating plate: to mount corona points (resistance to ground $> 10^{14} \Omega$)
 - earthed top surface: to shield fieldmeter
- 4 earthed casing
- 5 sample
- 6 open-shielded backing

NOTE all dimensions are nominal

Figure 6 – Example of an arrangement for measurement of charge decay**4.13.4 Test sample**

The sample is typically a garment material of at least 60 mm in diameter. Remove any loose powder by gently brushing or blowing with clean air. Further cleaning should only be done by agreement between customer and test house. However, do not test obviously contaminated parts.

The atmosphere for conditioning and testing shall be $(23 \pm 2) ^\circ\text{C}$ and $(25 \pm 5) \%$ relative humidity. The conditioning time prior to the testing shall be at least 48 h, or as otherwise agreed between customer and test house.

4.13.5 Procedure

The test procedure is as follows:

- 1) Clamp the garment in the apparatus.
- 2) Move the middle plate so that the corona points are effectively placed and the field meter is shielded.

- 3) Apply 5 kV to 10 kV negative on the corona points for $(1 \pm 0,5)$ seconds.
- 4) Remove the middle plate so that the field meter can measure the equivalent surface potential of the probe.
- 5) Measure the charge decay from the initial voltage to the agreed lower voltage level.
- 6) Repeat steps 2 to 5 two times on different locations.
- 7) Repeat steps 1 to 6 with positive polarity.

4.13.6 Acceptance criteria

Acceptable decay time is dependent on the charging processes involved in the application. For manual processes where charging is dependent on human activity, a decay time from 1 000 V to 100 V in about 1 s to 2 s is generally acceptable. Where charging currents are higher, shorter decay times may be required.

NOTE Less vague acceptance criteria are not available.

4.13.7 Test report

- The test report shall include at least the following information:
- measuring laboratory,
- date of measurement,
- temperature and relative humidity,
- description and identification of the sample,
- test results,
- applied corona voltage,
- charging time,
- identification of the instrumentation used,
- number of this standard.

4.14 Breakdown voltage

4.14.1 General

The electrical breakdown voltage shall be measured according to the short-time (rapid rise) test in IEC 60243-1 with the additional requirements of IEC 60243-2 for DC testing.

4.14.2 Principle

The test sample is placed between two metal electrodes. A DC voltage is applied and increased until breakdown occurs.

4.14.3 Apparatus

In cases of plates, discs and sheets, the sample is placed between two metal cylinders. The first is (25 ± 1) mm in diameter, (25 ± 1) mm in height, pressed with 1 kg on the sample, and the second one (75 ± 1) mm in diameter, (10 ± 1) mm in height (see Figure 7). The edges of the metal cylinders shall be rounded with a radius of $(3 \pm 0,2)$ mm to avoid corona discharges. In the case of small hoses the electrodes shall be a metal rod closely in contact with the inside of the hose and a metal foil tape at the outer side of the specimen.

Dimensions in millimetres

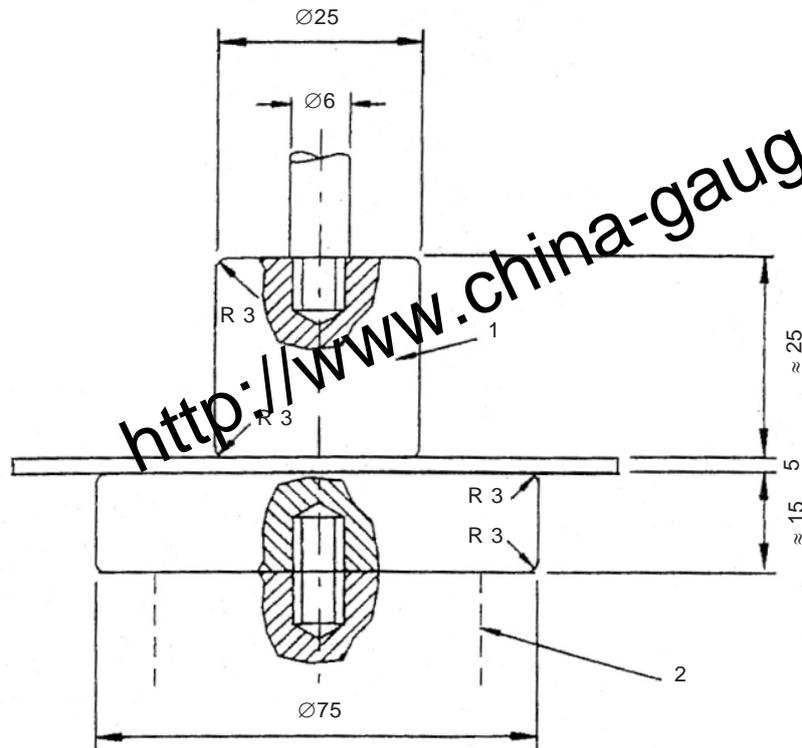

IEC

Key

- 1 metal
- 2 electrode support

Figure 7 – Electrodes for measuring breakdown voltage of sheets

The electrodes are connected to a DC HV generator with calibrated voltage and current displays. For normal electrostatic purposes, a maximum voltage of 20 kV is sufficient. However, in the case of tube testing a maximum voltage of 120 kV is necessary.

4.14.4 Test procedure

The test procedure is as follows:

- 1) Acclimate the samples at $(23 \pm 2) ^\circ\text{C}$ and $(25 \pm 5) \%$ relative humidity except when other conditions have been agreed.
- 2) Place a sample between the electrodes in the same climate.
- 3) Apply a DC voltage between the electrodes and slowly increase it from 0 V. At voltages up to 6 kV, a rate of 100 V/s is appropriate, at higher voltages the rate should be increased to 300 V/s.
- 4) Monitor the current monitored through this procedure.
- 5) Stop the test and record the actual voltage if either a rapid increase of current, often together with a bang and smoke, occurred, or an agreed upper limit of the current is reached.
- 6) If the output current of the DC power supply reaches 1 mA before the electrode voltage reaches 4 kV (6 kV in case of fabrics), the material under test shall be deemed to have a sufficiently low breakdown voltage.

NOTE More details about this measuring procedure can be found in IEC 60243-1 and IEC 60243-2.

4.14.5 Acceptance criteria

The maximum allowed value depends on the type of the hazardous area and is given in IEC TS 60079-32-1.

4.14.6 Test report

The test report shall include at least the following information:

- measuring laboratory,
- date of measurement,
- temperature and relative humidity,
- description and identification of the sample,
- arithmetic median breakdown voltage or reaching 1 mA limit, whichever is applicable,
- identification of the instrumentation used,
- number of this standard.

<http://www.china-gauges.com/>

Bibliography

- [1] IEC 60079-1, *Explosive atmospheres – Part 1: Equipment protection by flameproof enclosures "d"*
- [2] IEC 60079-7, *Explosive atmospheres – Part 7: Equipment protection by increased safety "e"*
- [3] IEC 60079-10-1, *Explosive atmospheres – Part 10-1: Classification of areas – Explosive gas atmospheres*
- [4] IEC 60079-10-2, *Explosive atmospheres – Part 10-2: Classification of areas – Combustible dust atmospheres*
- [5] IEC 60167, *Methods of test for the determination of the insulation resistance of solid insulating materials*
- [6] IEC 61241-2-3, *Electrical apparatus for use in the presence of combustible dust – Part 2: Test methods – Section 3: Method for determining minimum ignition energy of dust/air mixtures*
- [7] IEC TR 61340-1, *Electrostatics – Part 1: Electrostatic phenomena – Principles and measurements*
- [8] IEC 61340-4-1, *Electrostatics – Part 4-1: Standard test methods for specific applications – Electrical resistance of floor coverings and installed floors*
- [9] IEC 61340-4-3, *Electrostatics – Part 4-3: Standard test methods for specific applications – Footwear*
- [10] IEC 61340-4-5, *Electrostatics – Part 4-5: Standard test methods for specific applications – Methods for characterizing the electrostatic protection of footwear and flooring in combination with a person*
- [11] ISO 284, *Conveyor belts – Electrical conductivity – Specification and test method*
- [12] ISO 8031, *Rubber and plastics hoses and hose assemblies – Determination of electrical resistance*
- [13] ISO 8330, *Rubber and plastics hoses and hose assemblies – Vocabulary*
- [14] ISO 10965, *Textile floor coverings – Determination of electrical resistance*
- [15] ASTM F150, *Standard Test Method for Electrical Resistance of Conductive and Static Dissipative Resilient Flooring*
- [16] EN 1149-1, *Protective clothing – Electrostatic properties – Part 1: Test method for measurement of surface resistivity*
- [17] EN 1149-2, *Protective clothing – Electrostatic properties – Part 2: Test method for measurement of the electrical resistance through a material (vertical resistance)*

⁹ To be replaced by IEC 62631-3-1, IEC 62631-3-2 and IEC 62631-3-3.

- [18] EN 1149-5, *Protective clothing – Electrostatic properties – Part 5: Material performance and design requirements*
- [19] EN 50050-1, *Electrostatic hand-held spraying equipment – Safety requirements – Part 1: Hand-held spraying equipment for ignitable liquid coating materials*
- [20] CENELEC TR 50404, *Code of practice for the avoidance of hazards due to static electricity*
- [21] DIN 51412-1, *Testing of petroleum products – Determination of the electrical conductivity, laboratory method.*
- [22] SAE J1645, *Fuel Systems and Components – Electrostatic Charge Migration*
- [23] J. N. Chubb, Measurement of charge transfer in electrostatic discharges, *J. Electrostatics* 64 (2006), pp. 321-325
- [24] J. Lucas, Bestimmung des spezifischen elektrischen Widerstands mit einer speziellen Messzelle. *Technische Sicherheit* 1 (2011), pp.33-36 (available in German only)
- [25] L. Perrin et al, Dust and electrostatic hazards, could we improve the current standards? *Journal of Loss Prevention in the Process Industries* 20 (2007) pp. 207-217
- [26] Schnier Hand coulombmeter HMG 11/02, Schnier Elektrostatik, Bayernstr. 13, 72768 Reutlingen-Rommelsbach, Germany (available in German only)
- [27] K. W. Stahmer, H. J. Teske, and M. Gerhold, Vergleichende Betrachtungen von Verfahren zur Bestimmung des Durchgangswiderstandes einer Staubschüttung. Abschlussbericht IFA-Projekt 3119, Institut für Arbeitsschutz der Deutschen Gesetzlichen Unfallversicherung, 2012 (available in German only)
- [28] U. von Pidoll, E. Brzostek and H.-R. Froechtenigt, Determining the incendivity of electrostatic discharges without explosive gas mixtures. *IEEE Trans. Industry Applications*, 40 (2004), pp. 1467-1475
- [29] prEN 16350, *Protective gloves – Gloves against electrostatic risks*
- [30] JNIOOSH TR 42, *Recommendations for Requirements for Avoiding Electrostatic Hazards in Industry*
-

<http://www.china-gauges.com/>

<http://www.china-gauges.com/>

British Standards Institution (BSI)

BSI is the national body responsible for preparing British Standards and other standards-related publications, information and services.

BSI is incorporated by Royal Charter. British Standards and other standardization products are published by BSI Standards Limited.

About us

We bring together business, industry, government, consumers, innovators and others to shape their combined experience and expertise into standards-based solutions.

The knowledge embodied in our standards has been carefully assembled in a dependable format and refined through our open consultation process. Organizations of all sizes and across all sectors choose standards to help them achieve their goals.

Information on standards

We can provide you with the knowledge that your organization needs to succeed. Find out more about British Standards by visiting our website at bsigroup.com/standards or contacting our Customer Services team or Knowledge Centre.

Buying standards

You can buy and download PDF versions of BSI publications, including British and adopted European and international standards, through our website at bsigroup.com/shop, where hard copies can also be purchased.

If you need international and foreign standards from other Standards Development Organizations, hard copies can be ordered from our Customer Services team.

Subscriptions

Our range of subscription services are designed to make using standards easier for you. For further information on our subscription products go to bsigroup.com/subscriptions.

With **British Standards Online (BSOL)** you'll have instant access to over 55,000 British and adopted European and international standards from your desktop. It's available 24/7 and is refreshed daily so you'll always be up to date.

You can keep in touch with standards developments and receive substantial discounts on the purchase price of standards, both in single copy and subscription format, by becoming a **BSI Subscribing Member**.

PLUS is an updating service exclusive to BSI Subscribing Members. You will automatically receive the latest hard copy of your standards when they're revised or replaced.

To find out more about becoming a BSI Subscribing Member and the benefits of membership, please visit bsigroup.com/shop.

With a **Multi-User Network Licence (MUNL)** you are able to host standards publications on your intranet. Licences can cover as few or as many users as you wish. With updates supplied as soon as they're available, you can be sure your documentation is current. For further information, email bsmusales@bsigroup.com.

BSI Group Headquarters

389 Chiswick High Road London W4 4AL UK

Revisions

Our British Standards and other publications are updated by amendment or revision.

We continually improve the quality of our products and services to benefit your business. If you find an inaccuracy or ambiguity within a British Standard or other BSI publication please inform the Knowledge Centre.

Copyright

All the data, software and documentation set out in all British Standards and other BSI publications are the property of and copyrighted by BSI, or some person or entity that owns copyright in the information used (such as the international standardization bodies) and has formally licensed such information to BSI for commercial publication and use. Except as permitted under the Copyright, Designs and Patents Act 1988 no extract may be reproduced, stored in a retrieval system or transmitted in any form or by any means – electronic, photocopying, recording or otherwise – without prior written permission from BSI. Details and advice can be obtained from the Copyright & Licensing Department.

Useful Contacts:

Customer Services

Tel: +44 845 086 9001

Email (orders): orders@bsigroup.com

Email (enquiries): cservices@bsigroup.com

Subscriptions

Tel: +44 845 086 9001

Email: subscriptions@bsigroup.com

Knowledge Centre

Tel: +44 20 8996 7004

Email: knowledgecentre@bsigroup.com

Copyright & Licensing

Tel: +44 20 8996 7070

Email: copyright@bsigroup.com